

# COUGAR KR

## Instruction Manual



**Schumacher**  
racing-cars.com

71-73 Tenter Road  
Moulton Park  
Northampton  
NN3 6AX  
U.K.

## Additional Items Required

Transmitter and Receiver  
(including batteries for tx)

CR151  
CODE 2.4G 2 Stick 3Ch Tx+Rx  
CR152  
CODE 2.4G 2 Stick 3Ch Receiver ONLY



Servo



Electronic  
Speed Control



Li-Po Battery



Motor



Pinion Gear



Battery Charger  
CR161



Paint

C4450  
CS Superglue 20g



Tyres and Inserts



Additional items

G796 Male Connector Plugs



SPW1403  
High Current 14AWG Wire



Tools



U2818  
Schumacher Body Reamer



U4229 Steel Spanner - 5.5mm/3.9mm



CR044 Curved Body Scissors



U2789 Hex Driver - 1.5mm  
U2790 Hex Driver - 2.0mm  
U2791 Hex Driver - 2.5mm  
U2792 Hex Driver - 3.0mm



U2795 M3 Nut Driver  
U2796 M4 Nut Driver



Soldering Iron  
CR266 40w  
CR275 80w

U3107 - Solder

# COUGAR<sup>KR</sup>

Schumacher Racing stocks and distributes the following manufacturers products and full product listings are available on our website at [www.racing-cars.com](http://www.racing-cars.com)

PLEASE NOTE THAT SOME OF THE PRODUCT RANGES BELOW ARE ONLY AVAILABLE IN THE UNITED KINGDOM.

**SPEC**

**East Coast**  
BODIES TUNE

**CS-ELECTRONIC**

**TEAM SOREX**

**AM**  
ARROWMAX

**CORE-RC**  
.COM

**NISRAM**

**Speed**  
Passion

**GM**  
RACING

**FTW**

**HOBBYWING**

**RHEINARD**  
R33D

**Motor Tech**  
RACING

**THUNDER POWER RC**

**team EDS**  
Specialized R/C Tools

**contact**  
RC RACING TYRES

### IMPORTANT SAFETY NOTES

- This product is not suitable for children under the age of 14, without the direct supervision of an adult.
- Select an area for assembly that is away from the reach of small children. The parts in this kit are small and can be swallowed by children causing choking and possible internal injuries.
- Exercise care when using hand tools and sharp instruments during assembly.
- Carefully read all manufacturers warnings and cautions for any additional parts used in the construction.
- In line with our policy of continuous development the exact details of the kit may vary.

Step 1 A

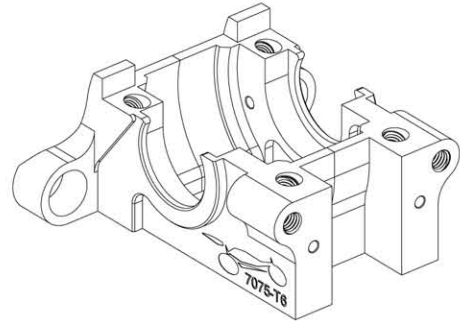
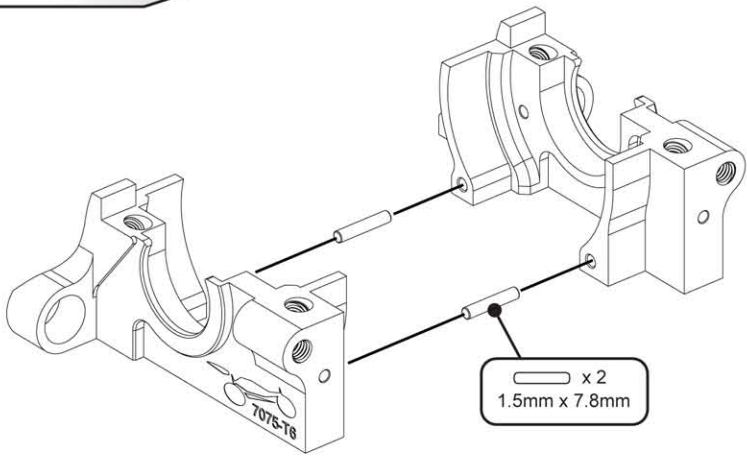

Step 1 B

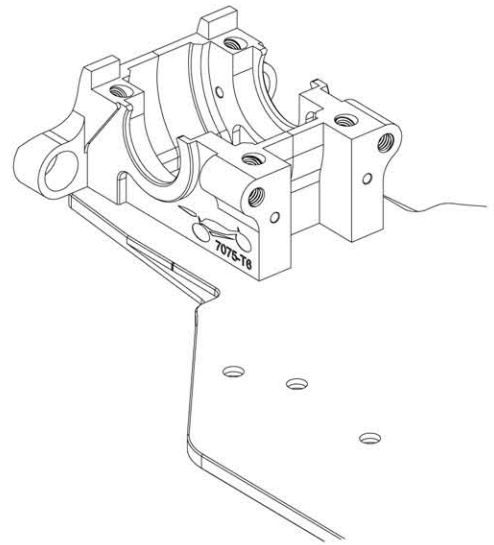
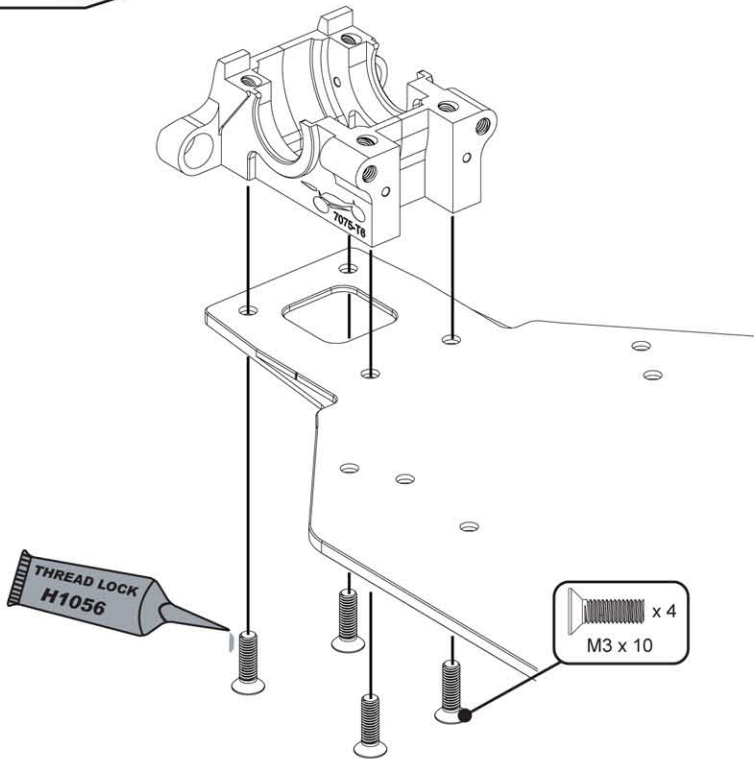

Step 2 A

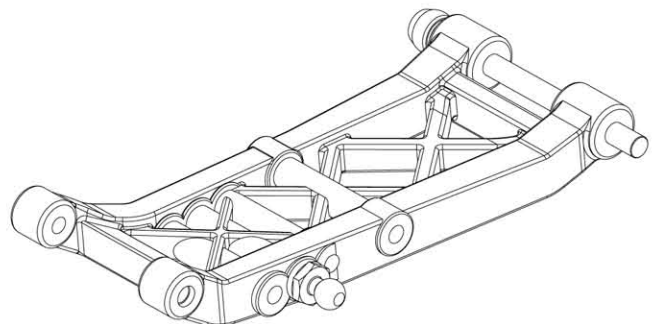
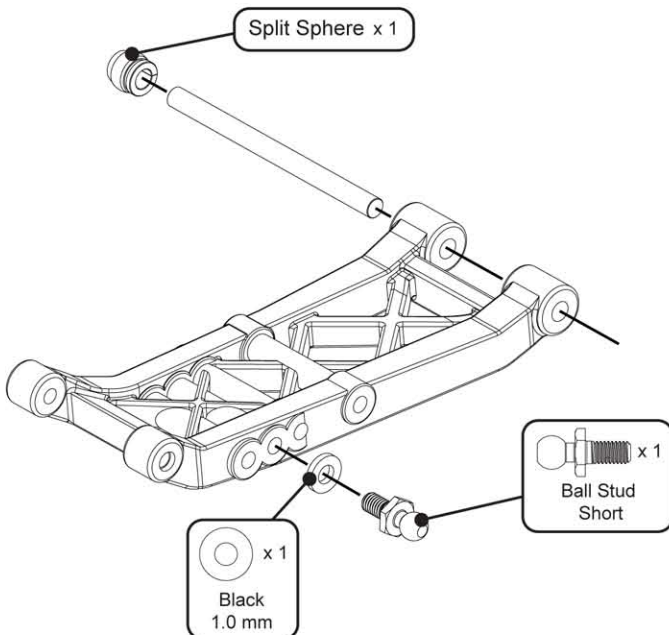

Push the Sphere into the trans housing (this should be a tight fit)

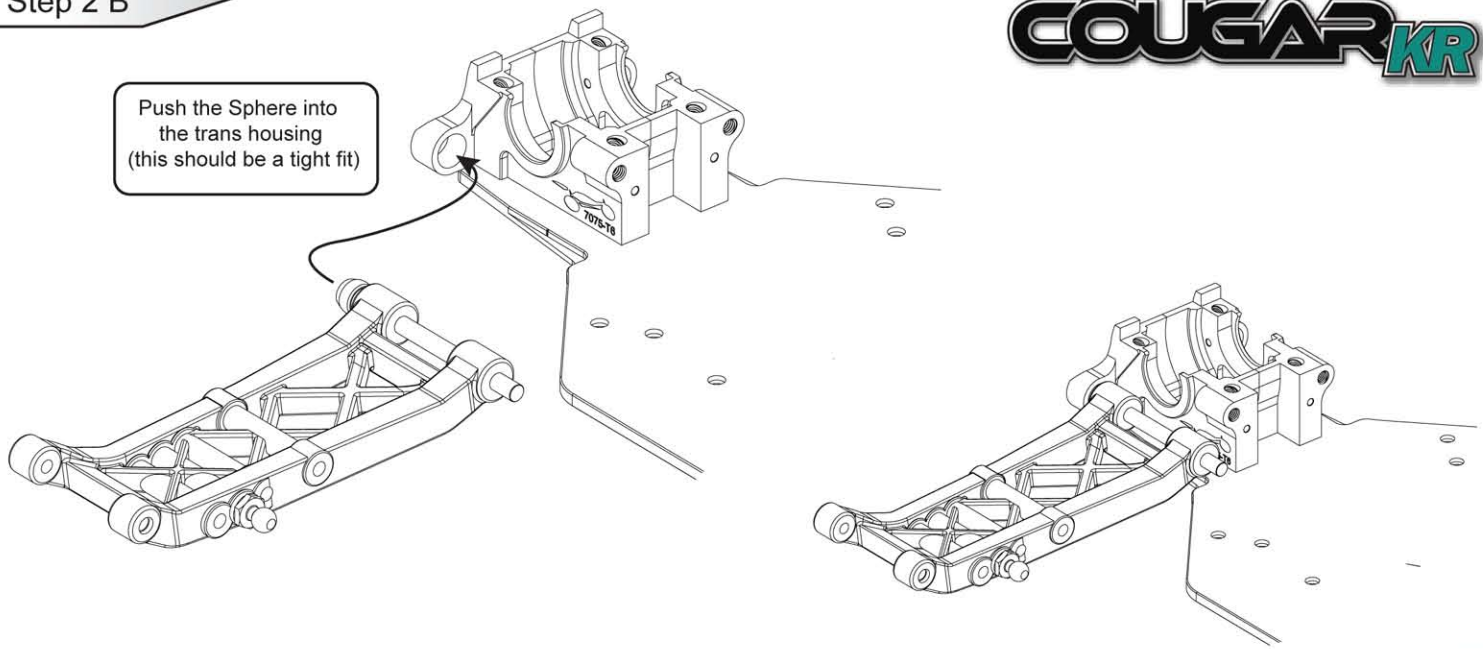

Step 3 A

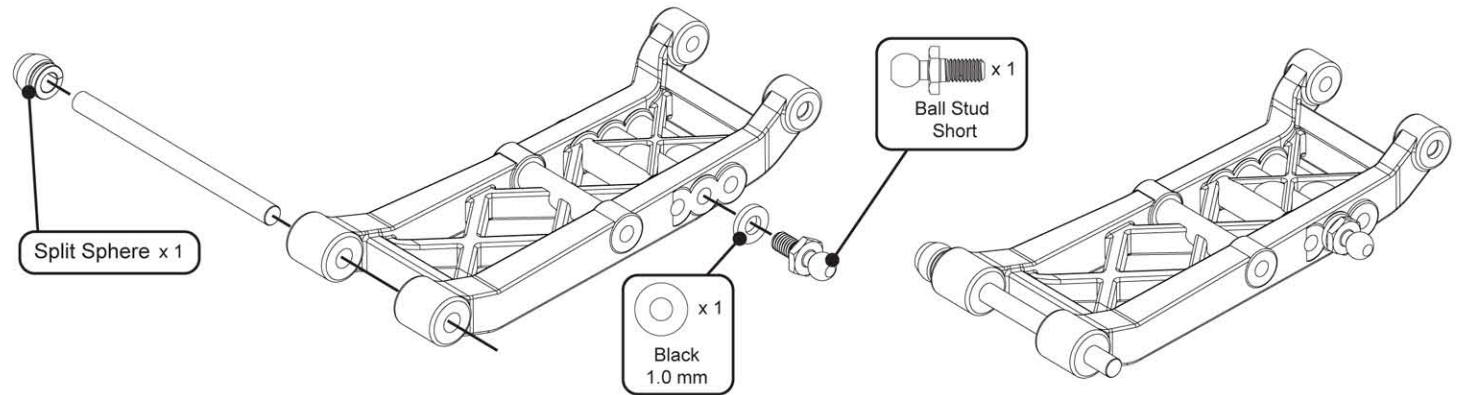

Step 3 B

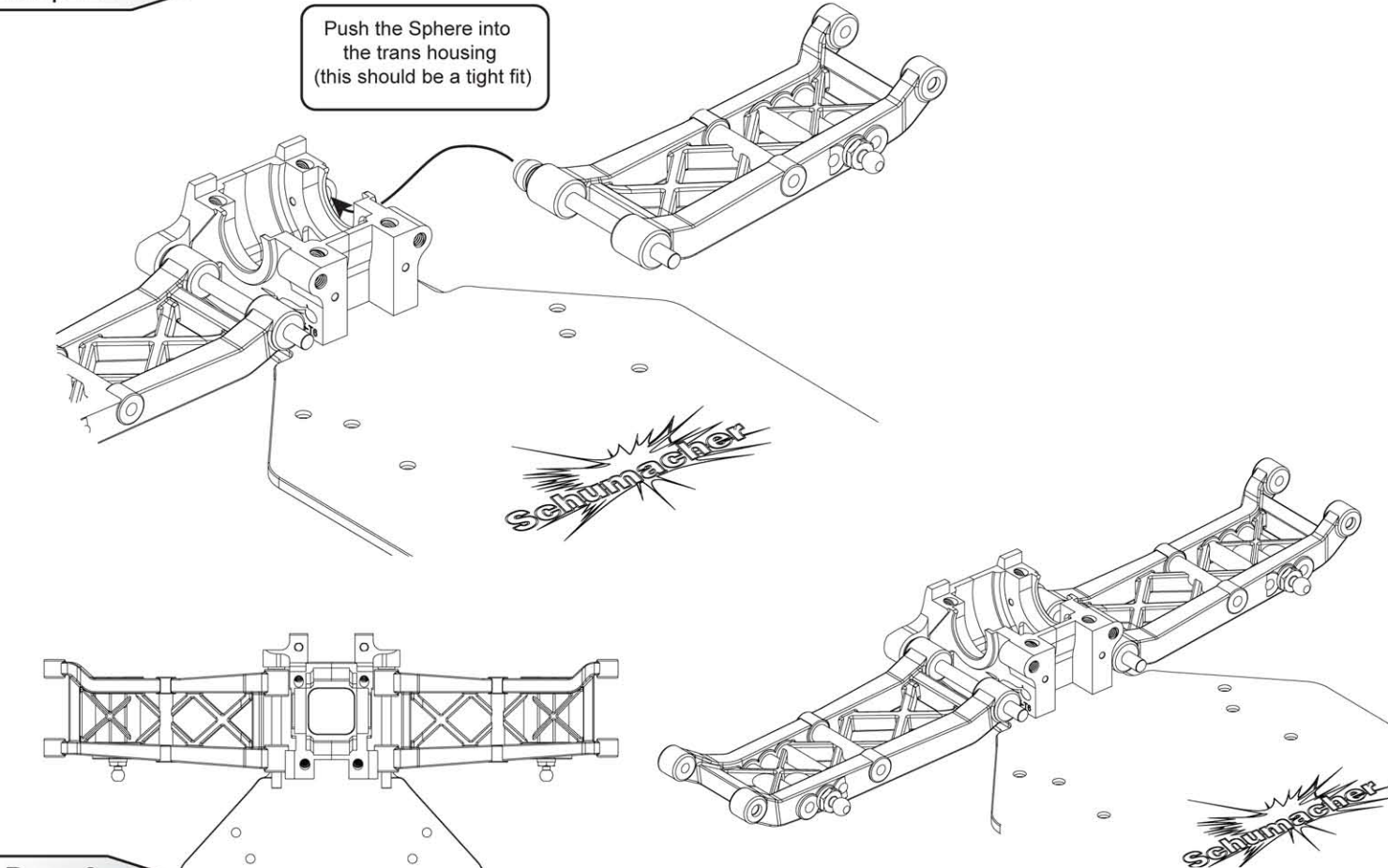

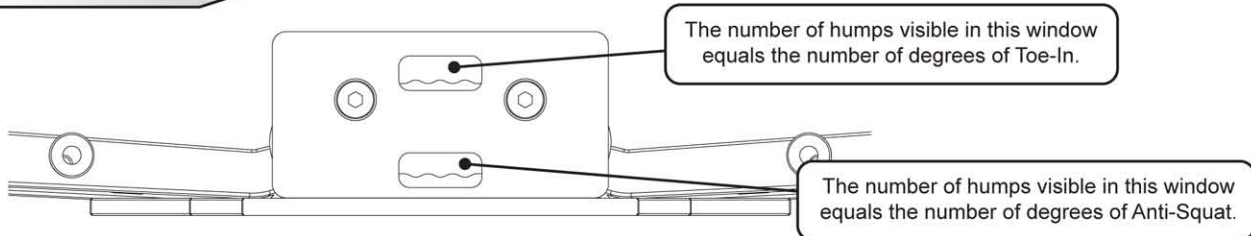
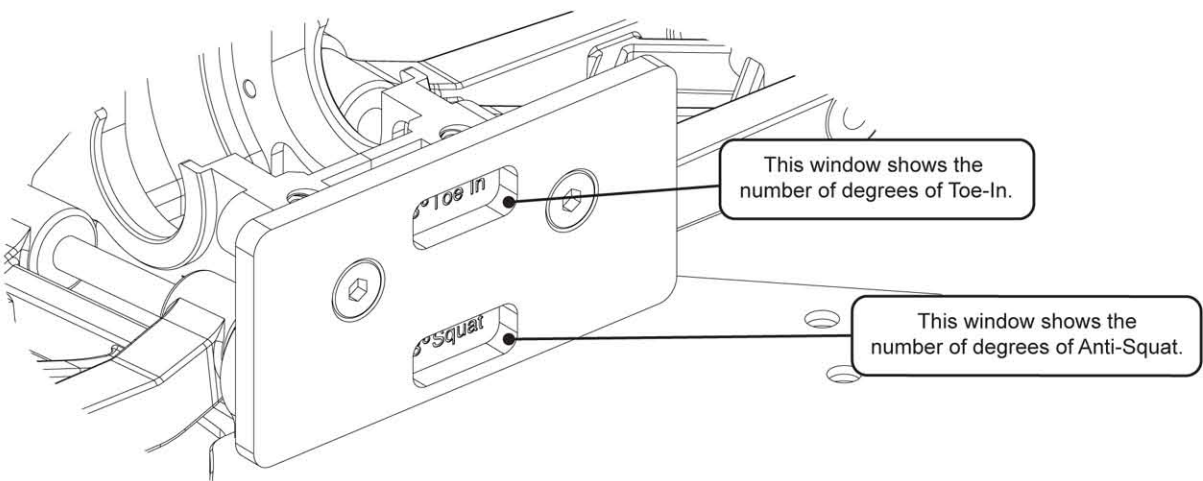
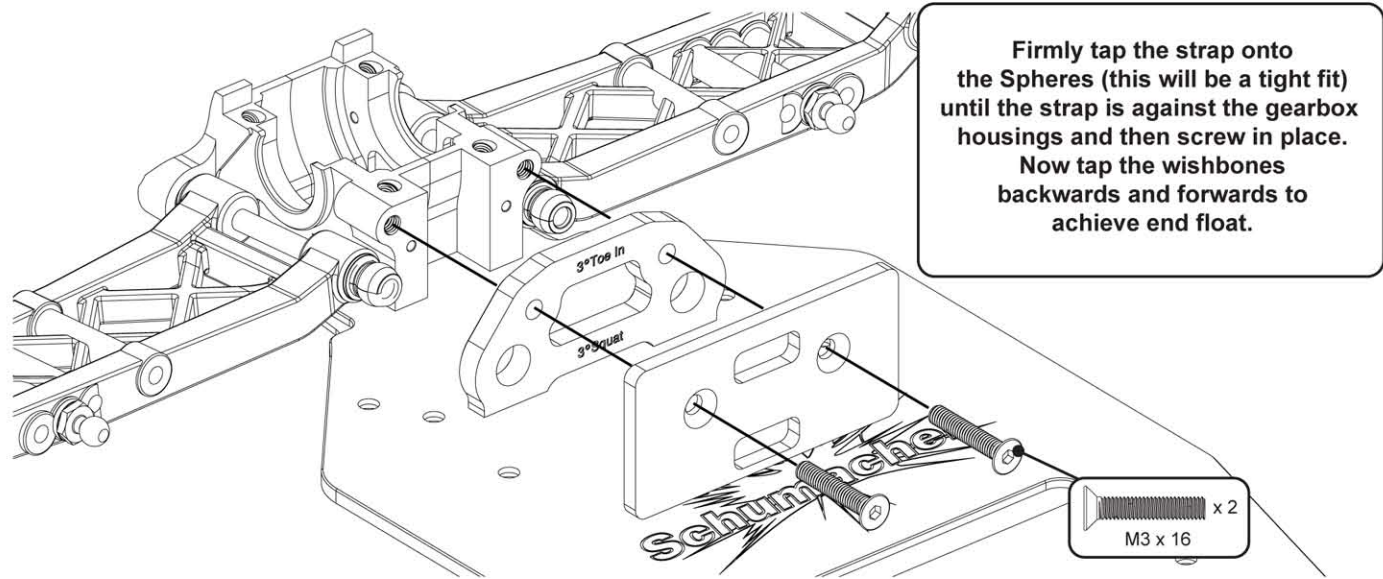
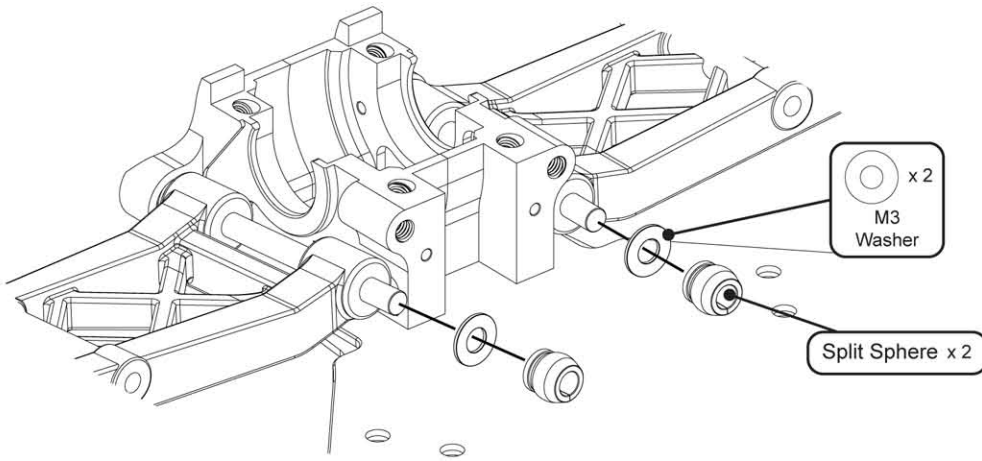

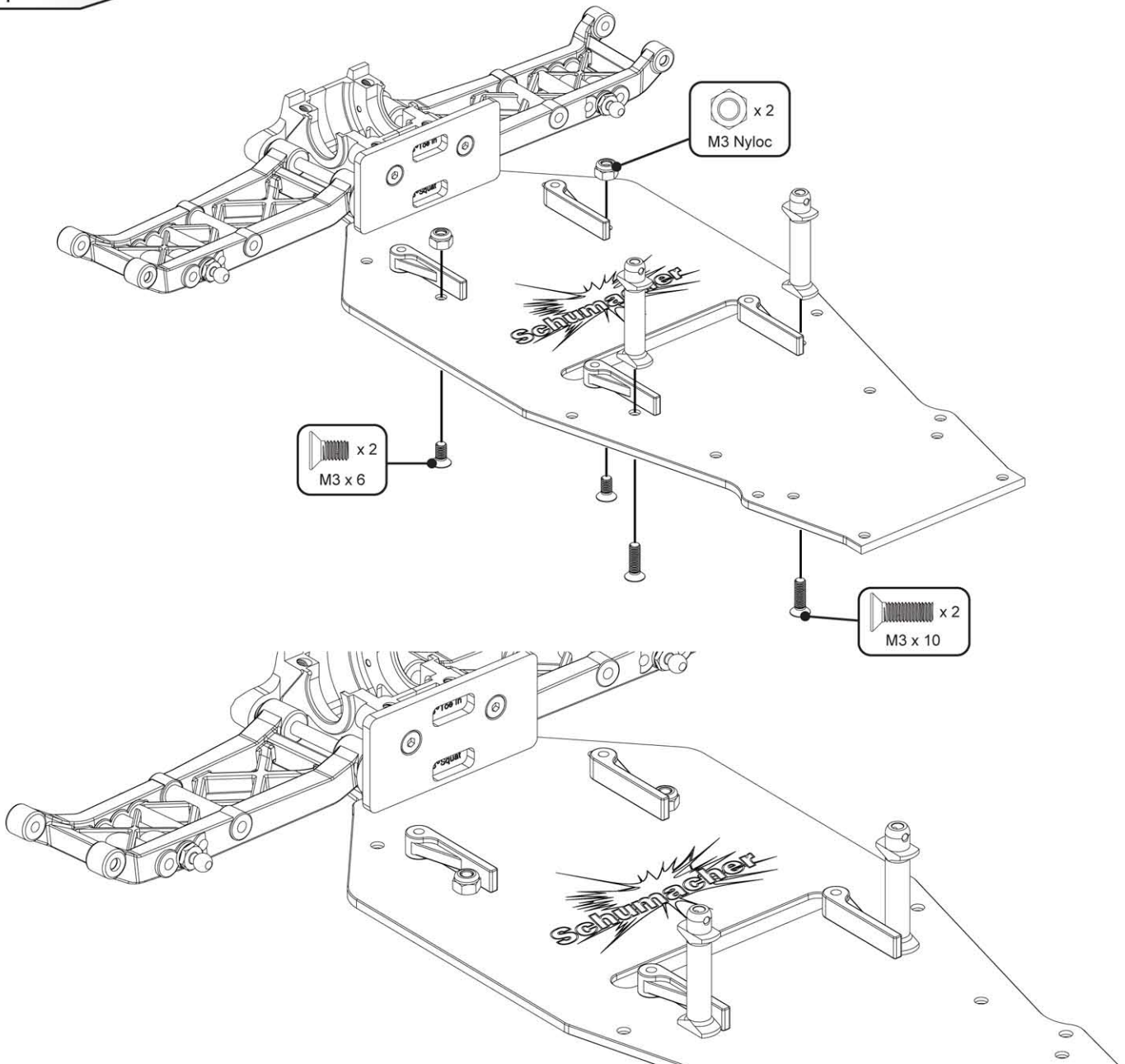
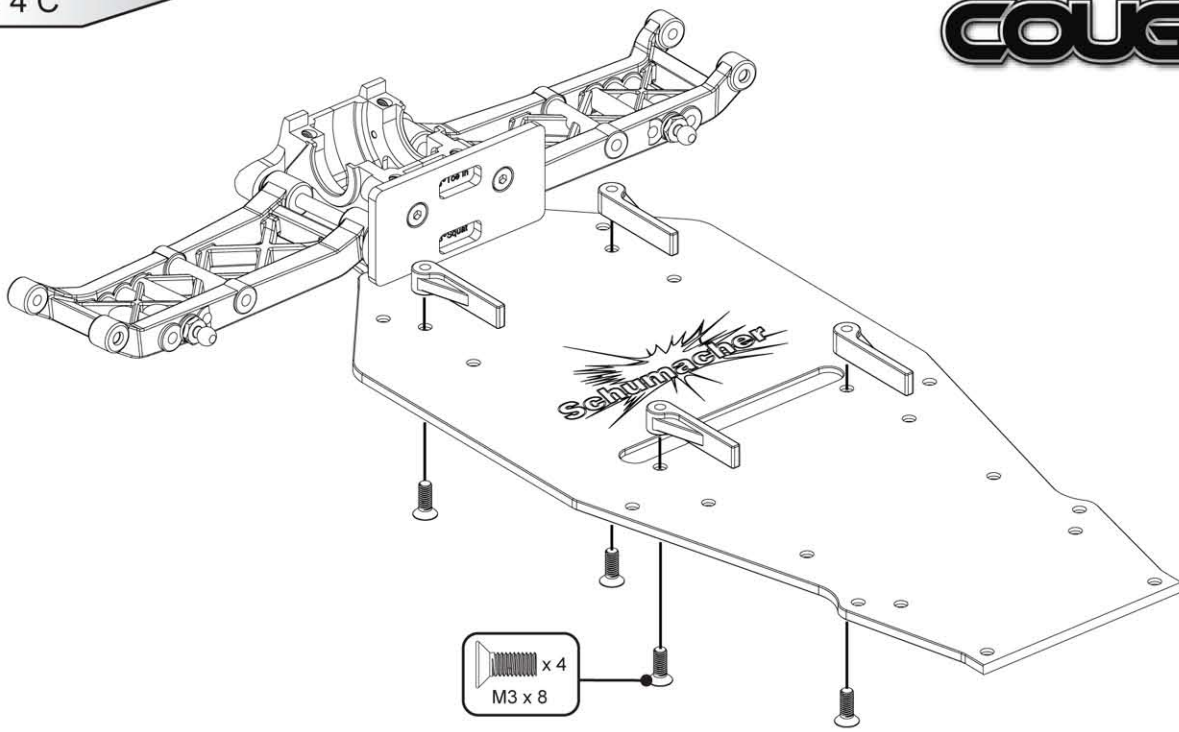

Step 5 B

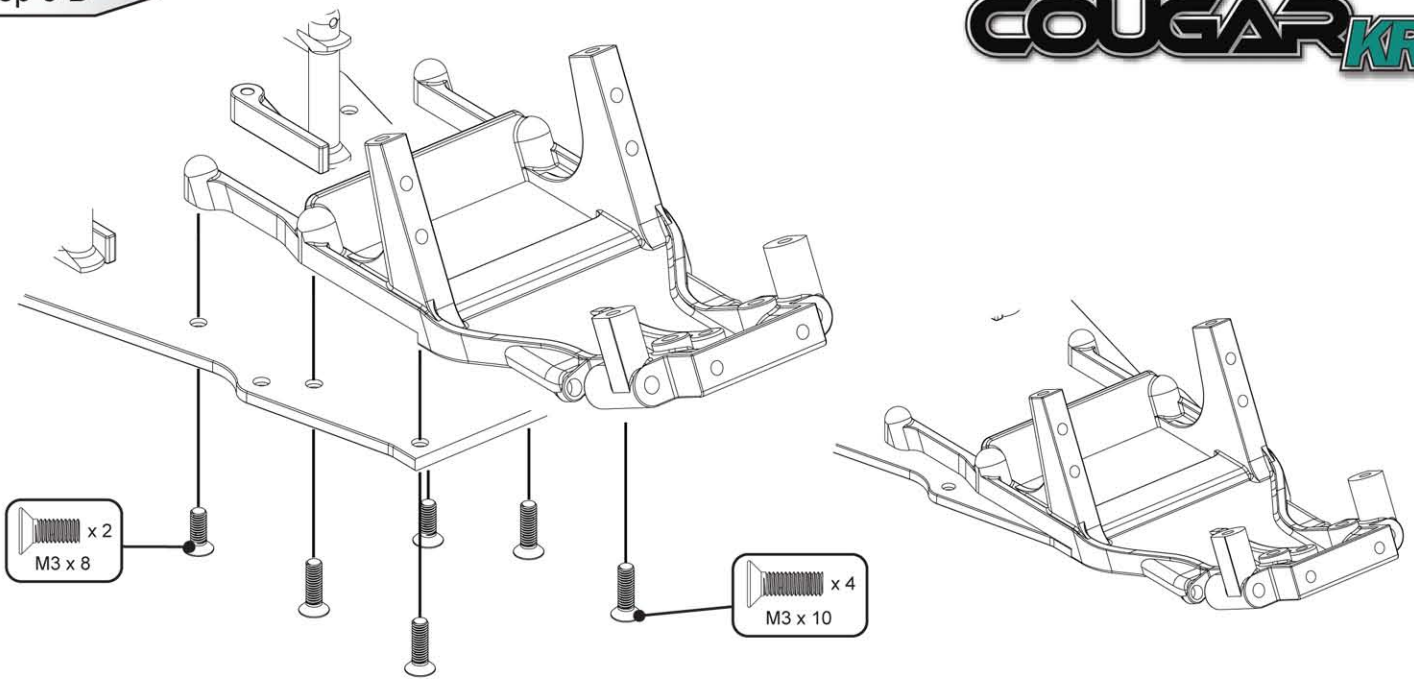

Step 6

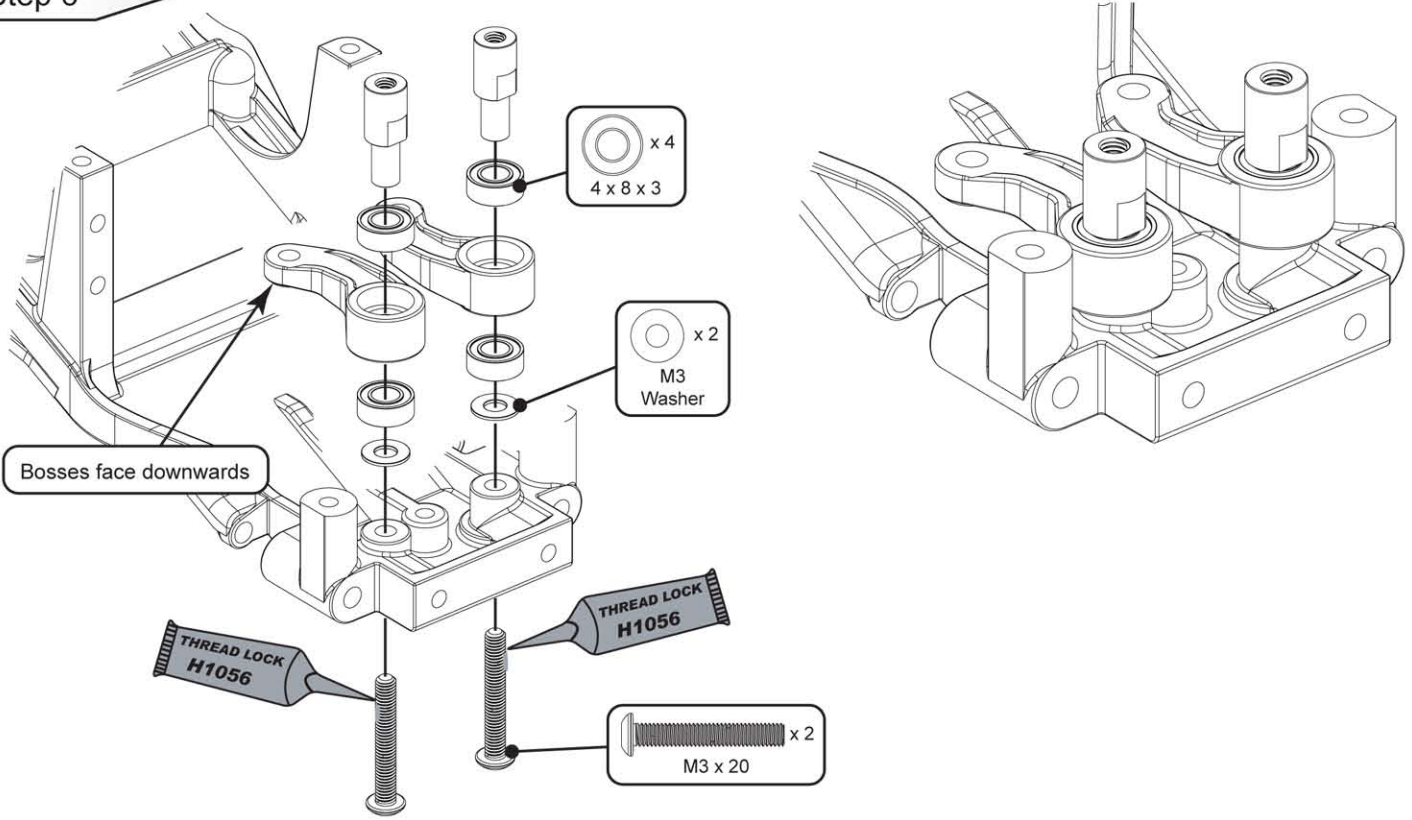

Step 7 A

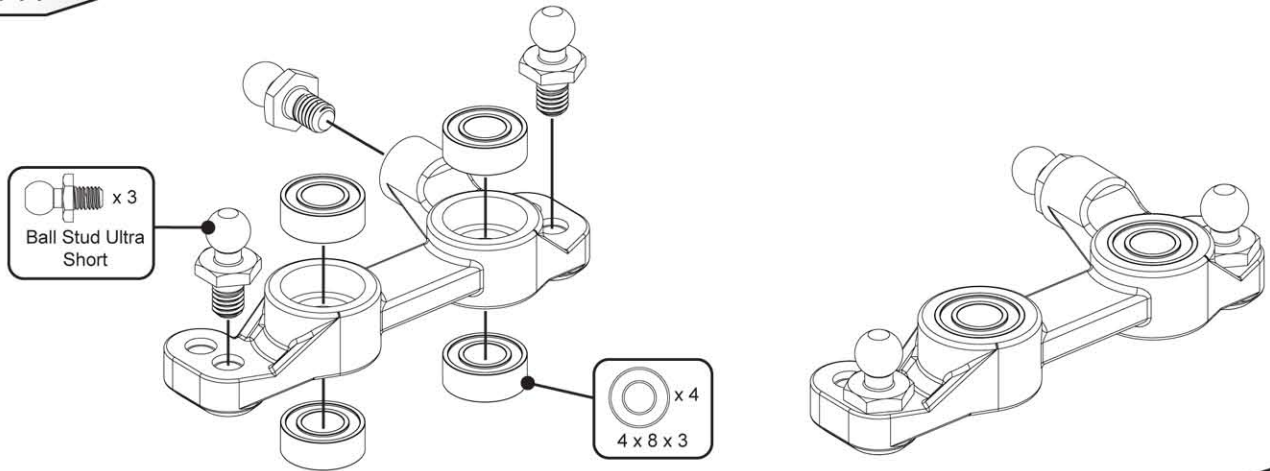

# Step 7 B



Lifting the centre track rod by adding additional washers softens the steering response around neutral.  
 Use up to a maximum of 4mm.  
 (you may need to use longer screws)  
**Important see steps 15 & 16**

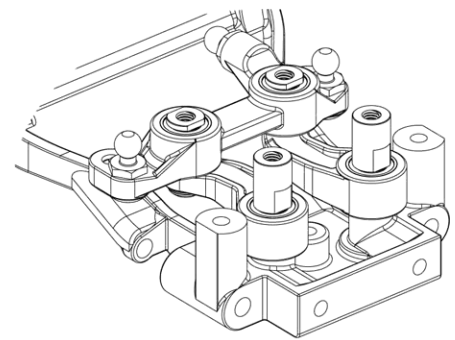
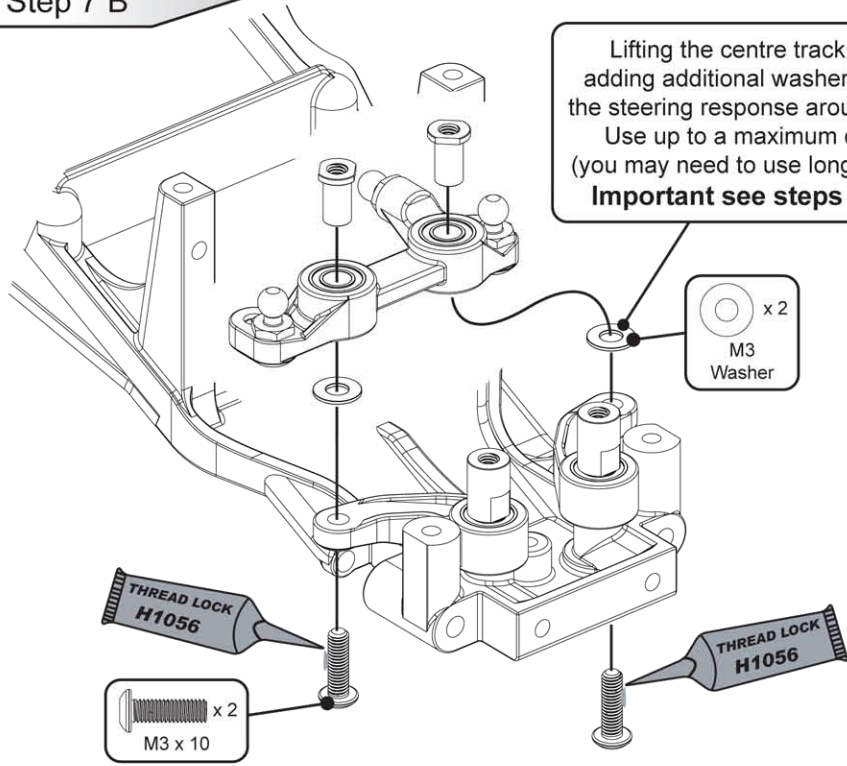

# Step 8

The servo must be as close as possible to this face

**OPTIONAL** spacers depending on servo length. When needed make sure the servo has equal spacers each side

When fitting both spacers use the M3 x 12 Screw

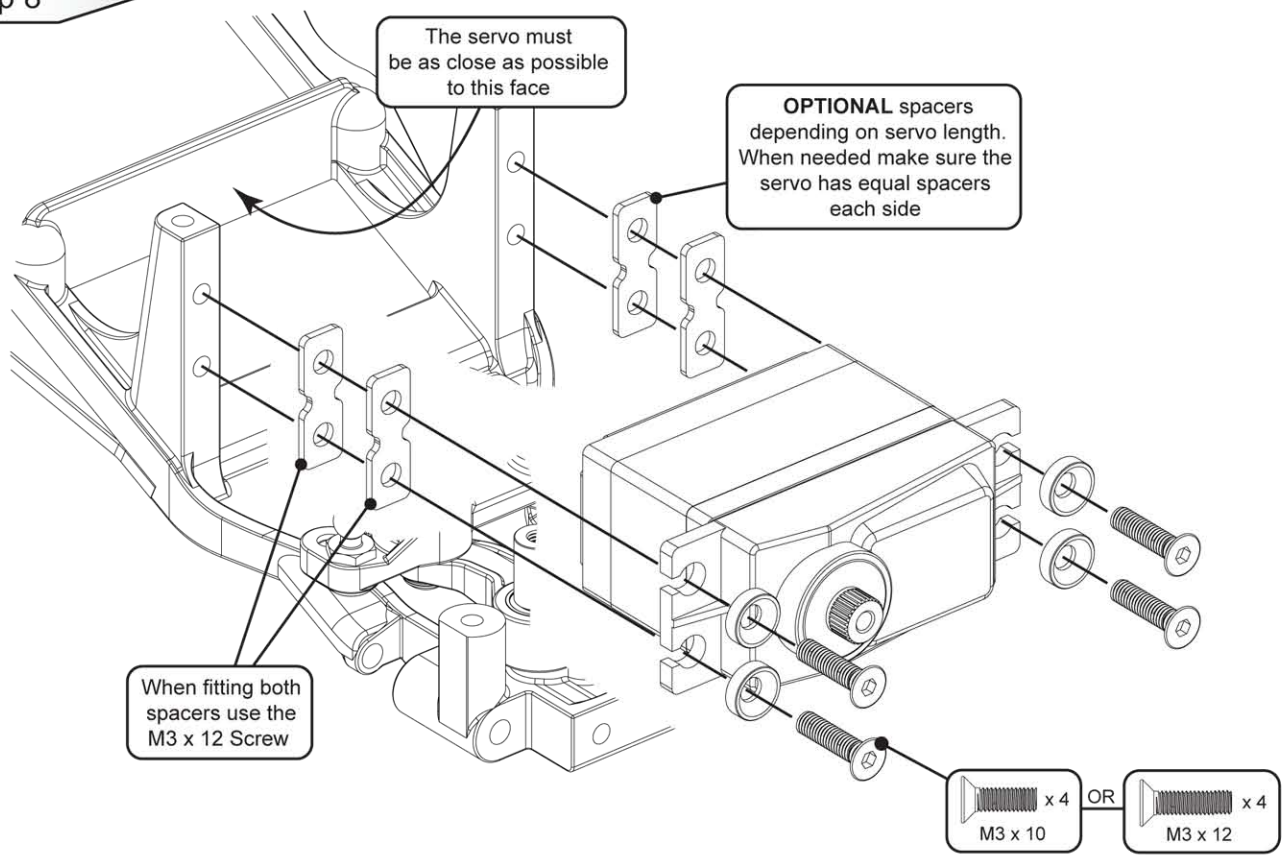

# Step 9 A

x 1  
M3 x 14

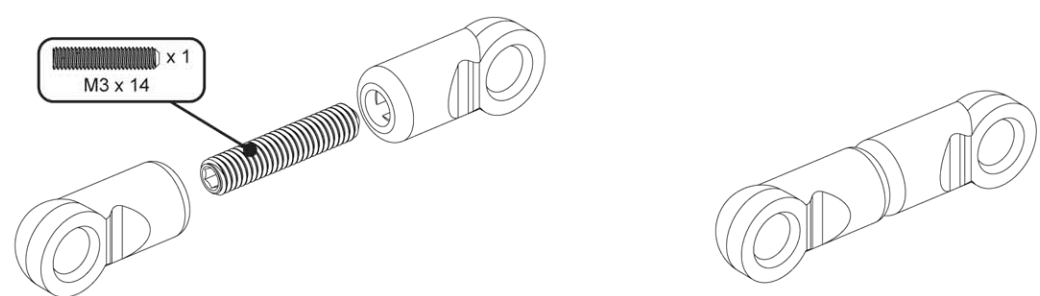



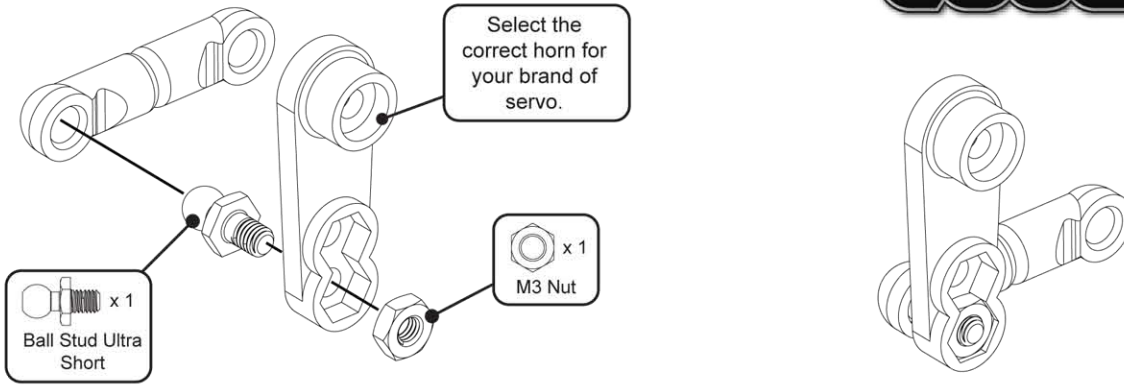

Before you assemble the servo horn, connect up your radio gear and set the steering servo to neutral.

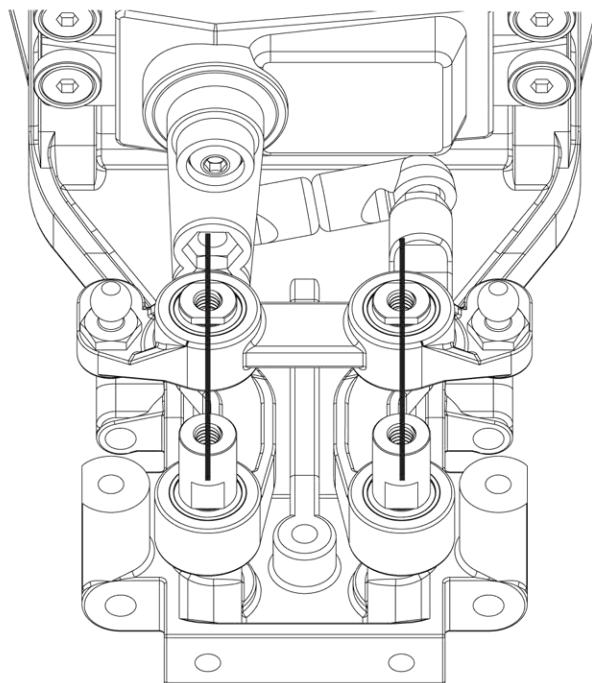
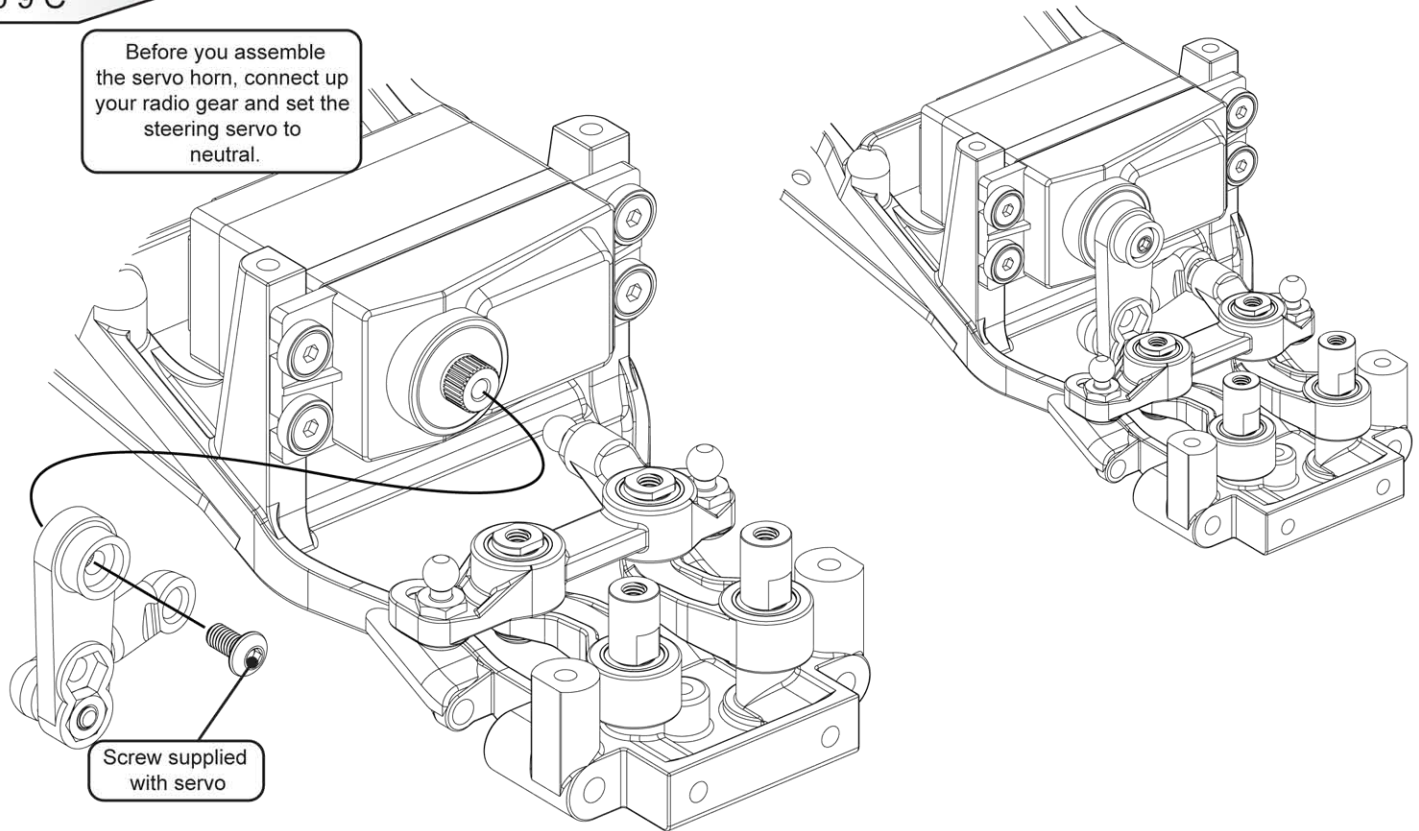

Step 10

**COUGAR** KR

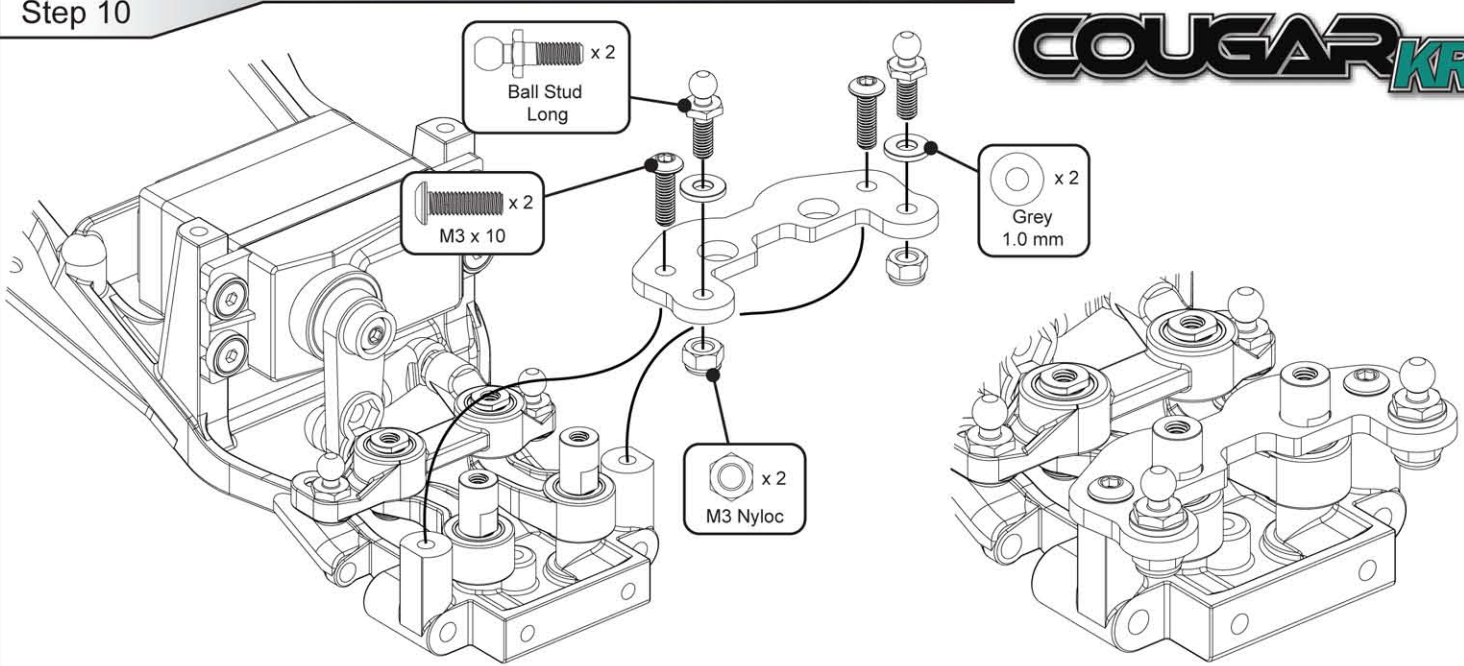

Step 11

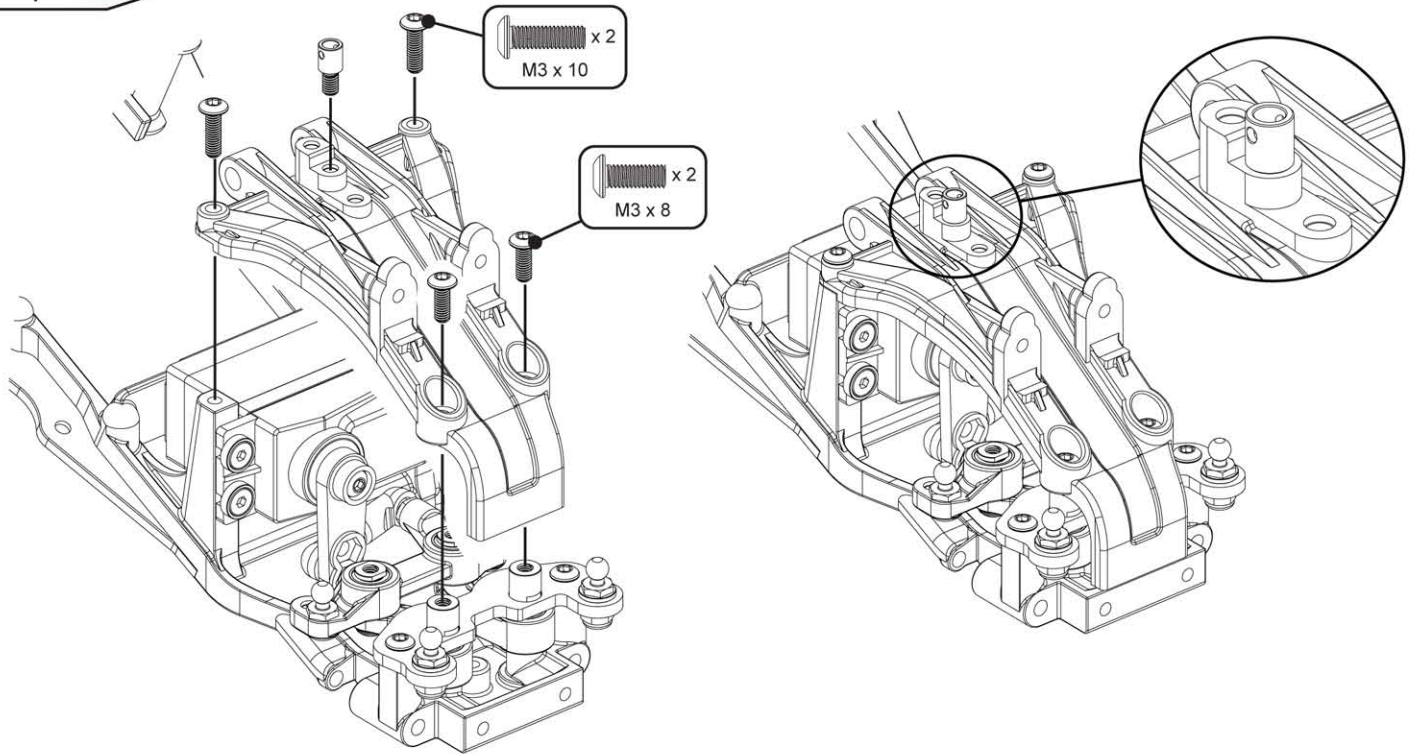

Step 12

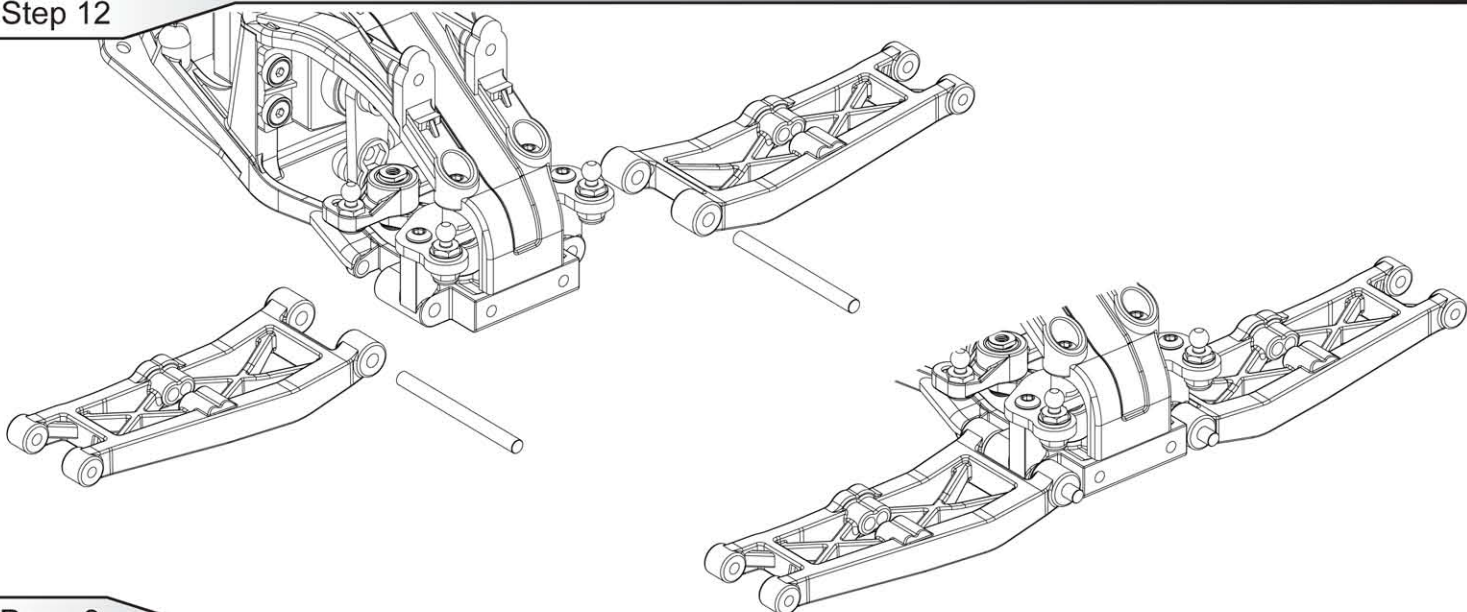

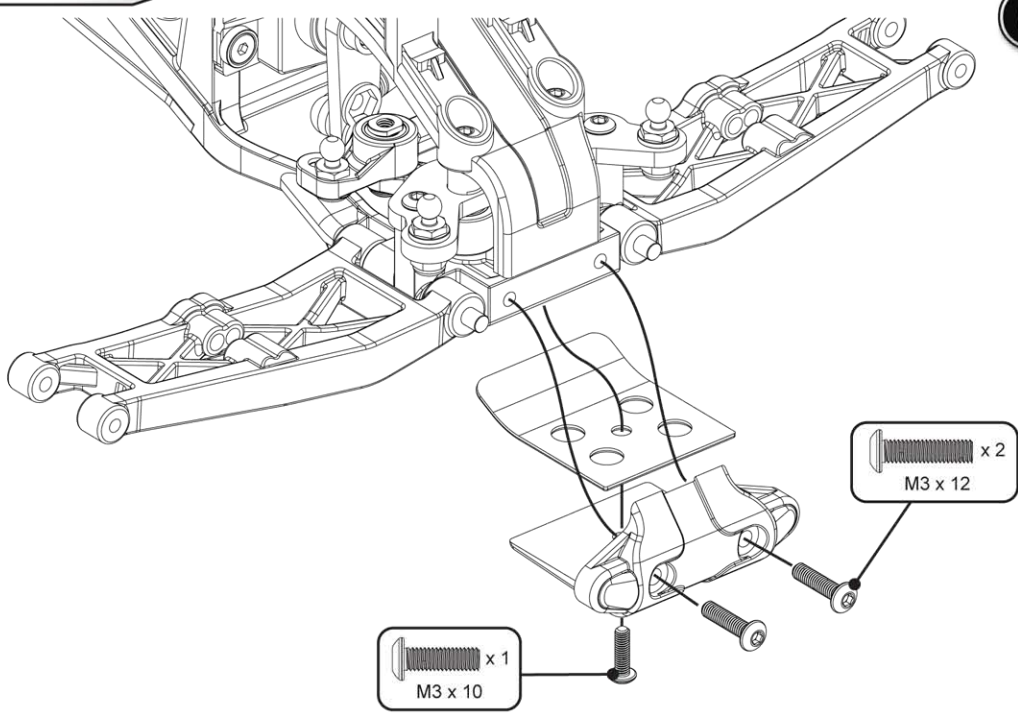

Step 14 A

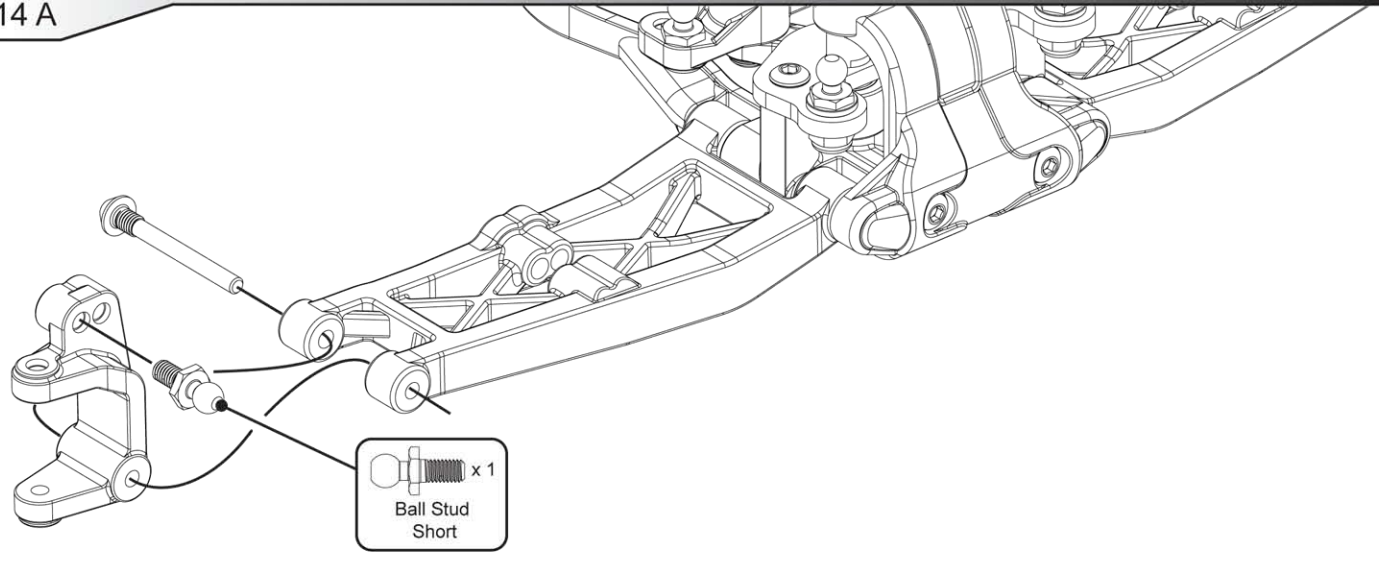

Step 14 B

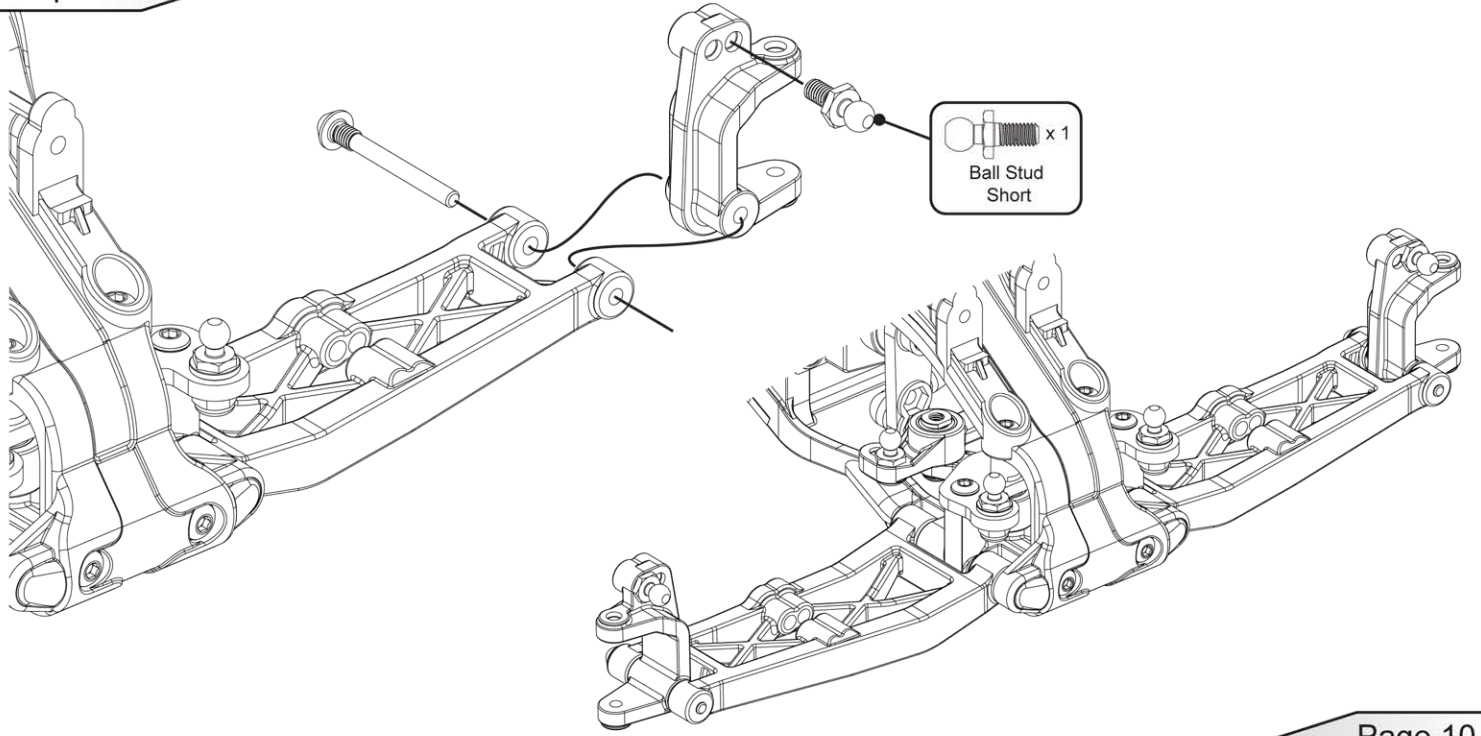



## Step 17 A

# COUGAR<sup>KR</sup>

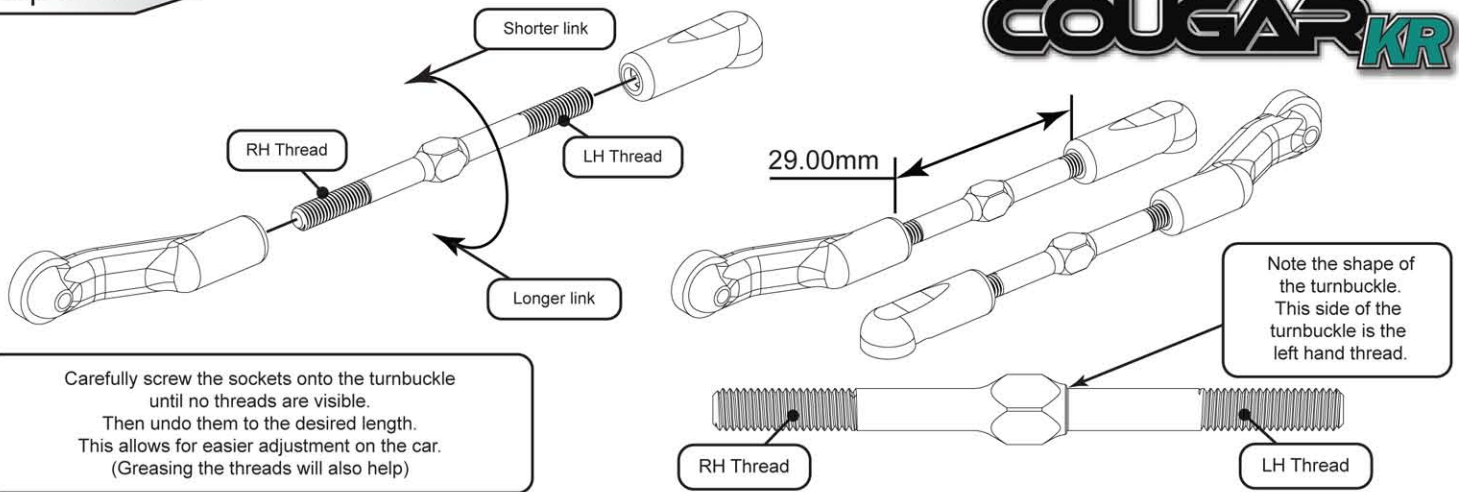

## Step 17 B

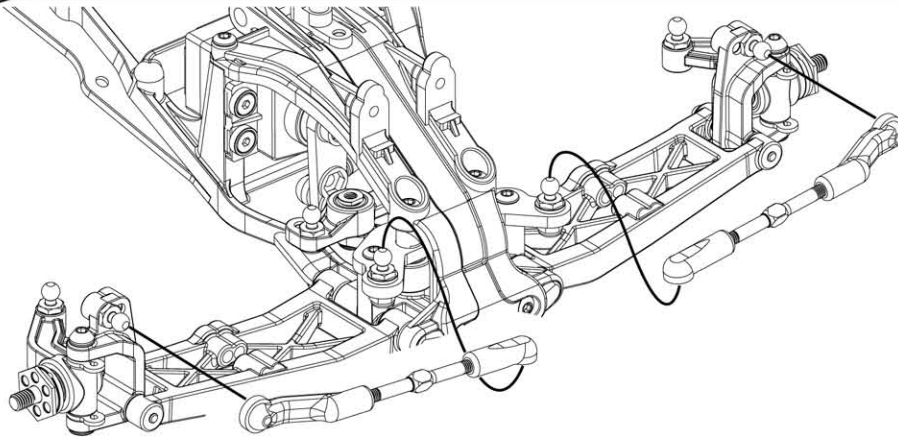

## Step 18 A

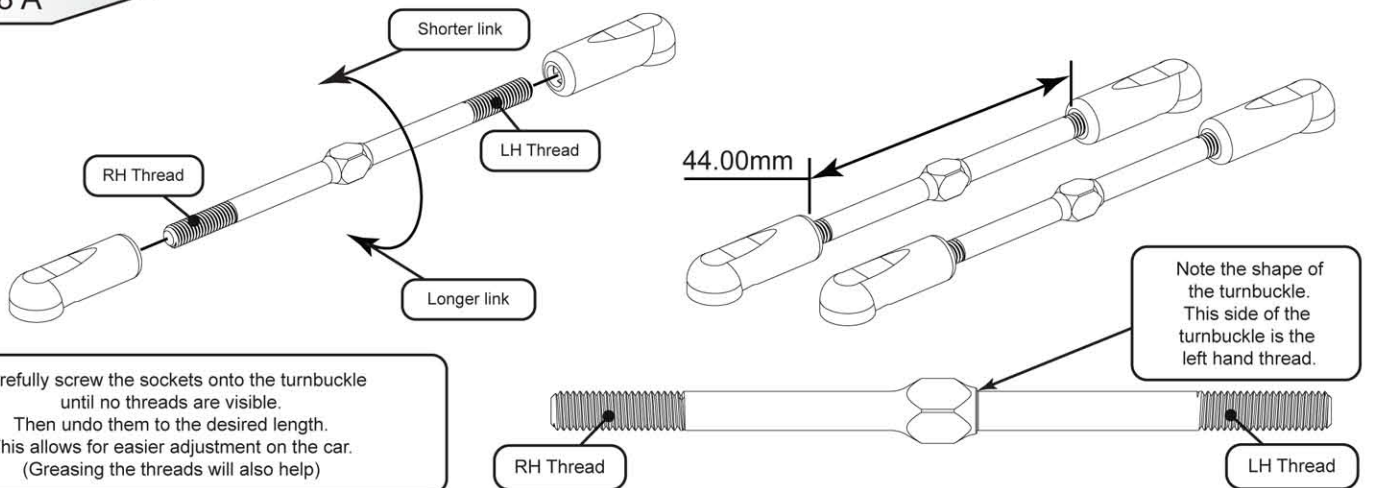

## Step 18 B

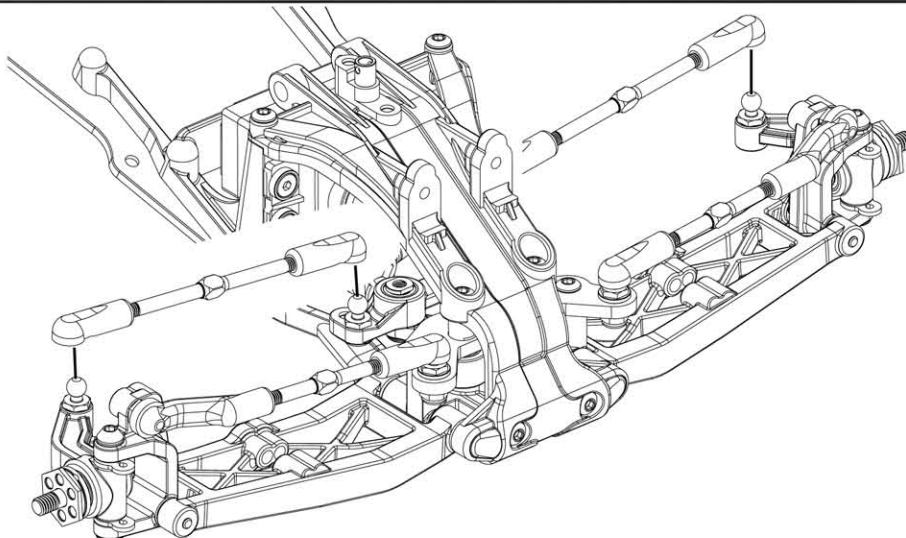

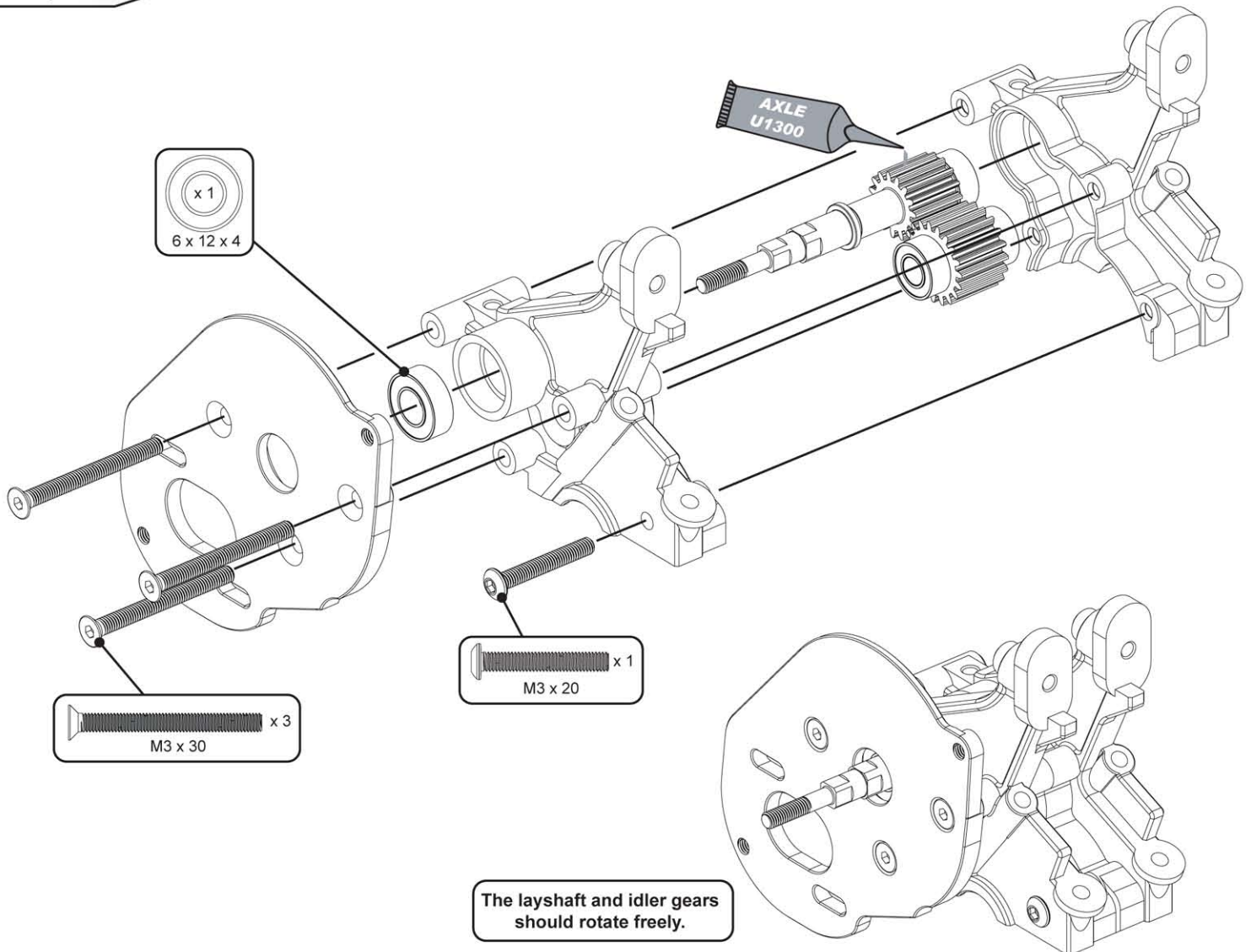
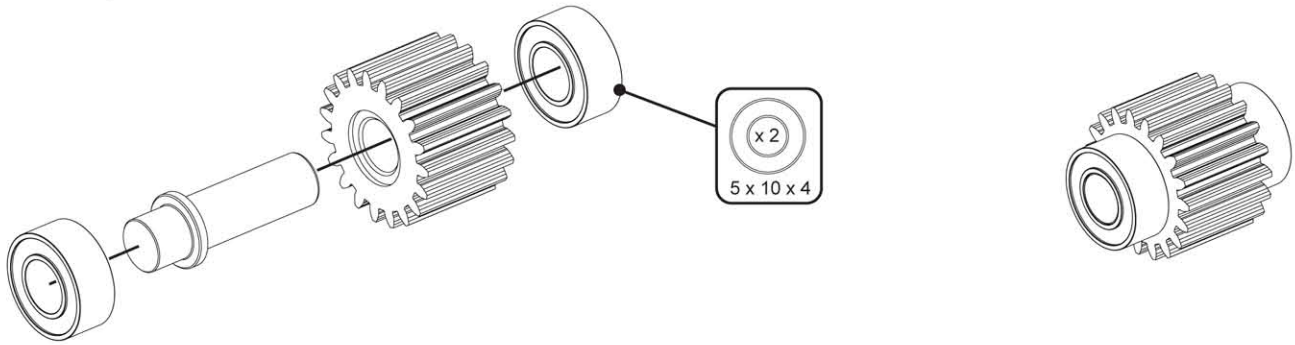
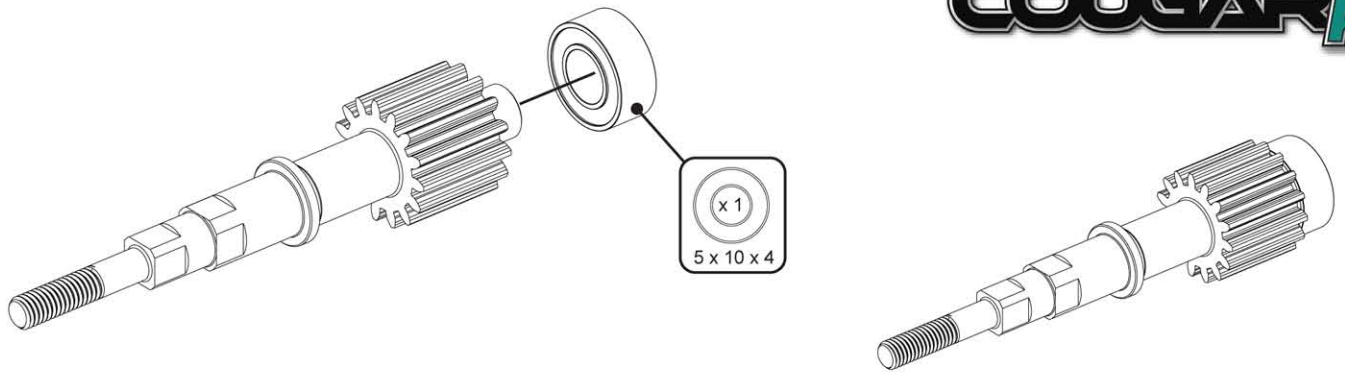

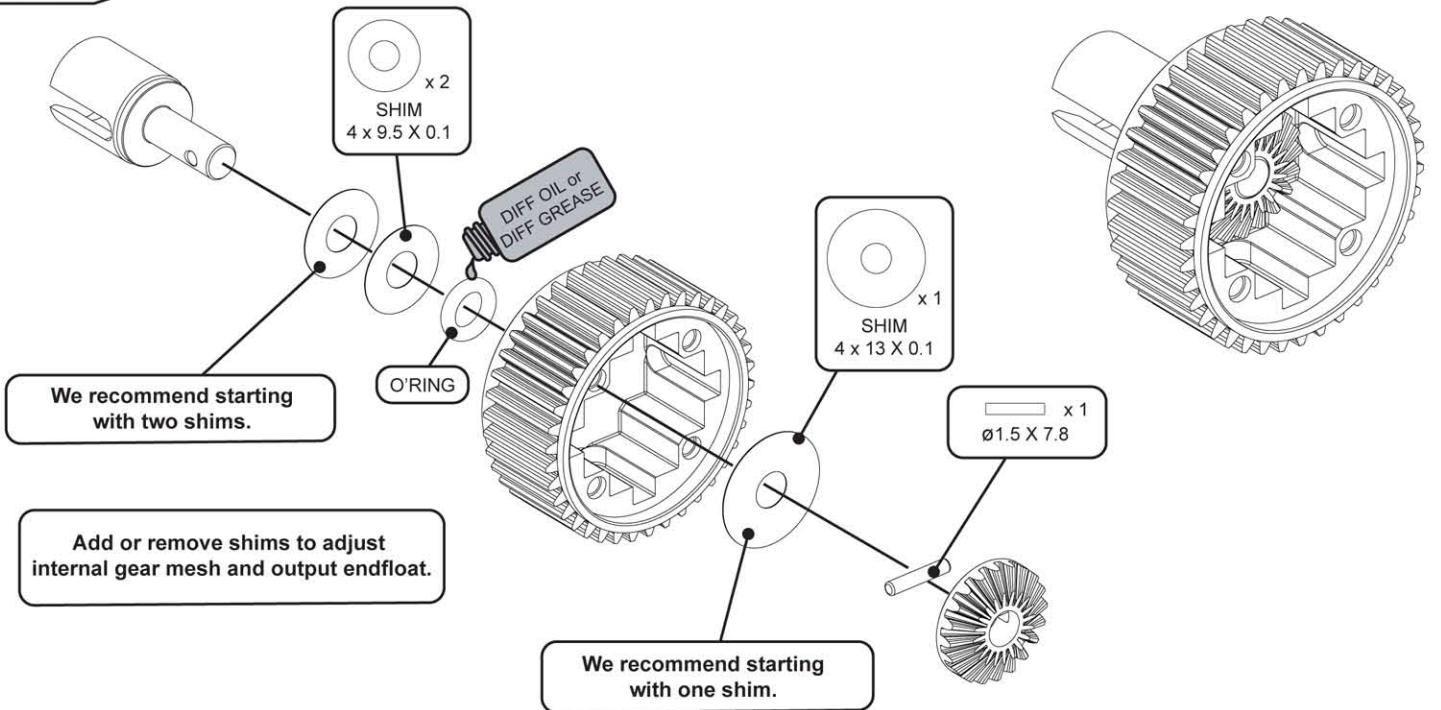
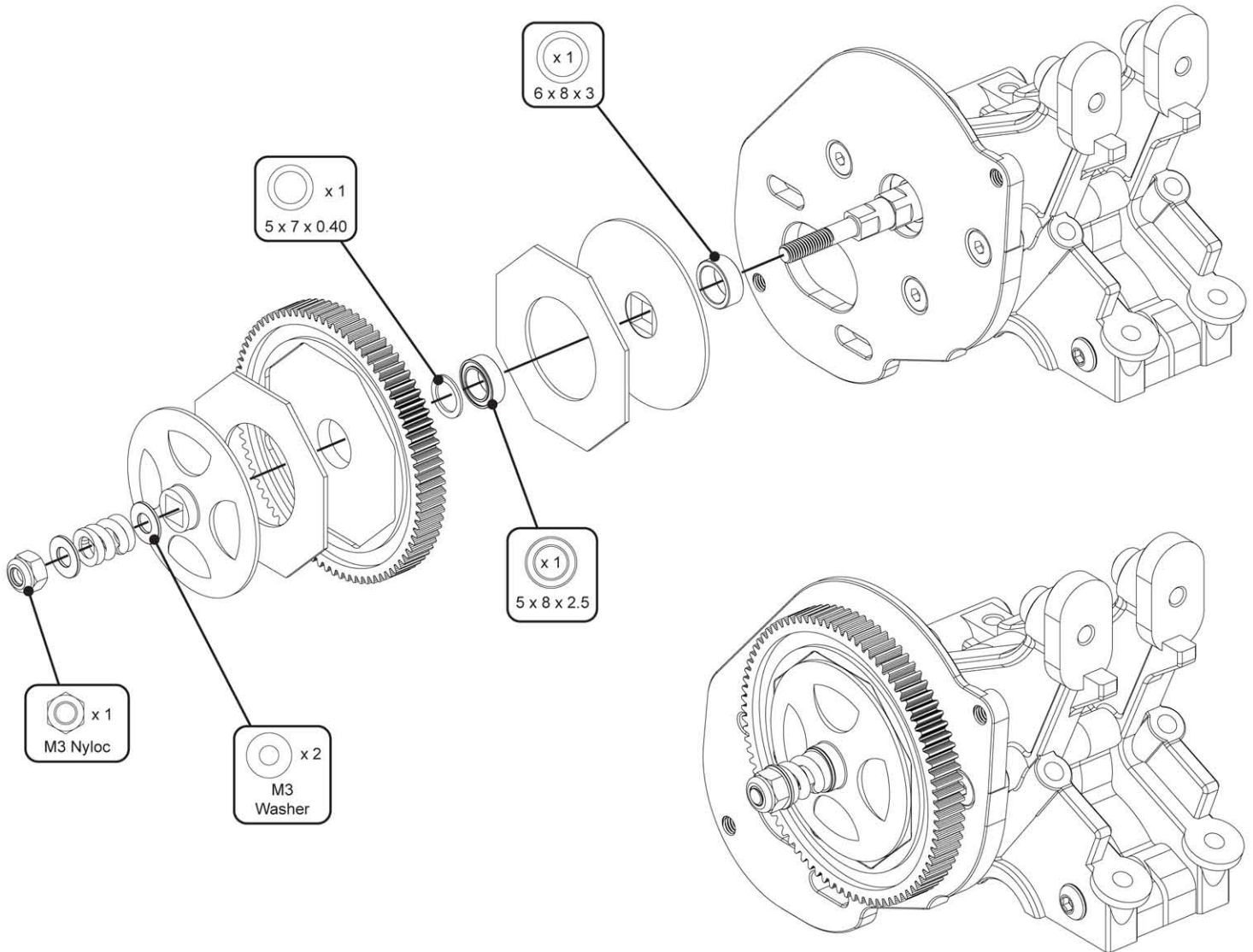

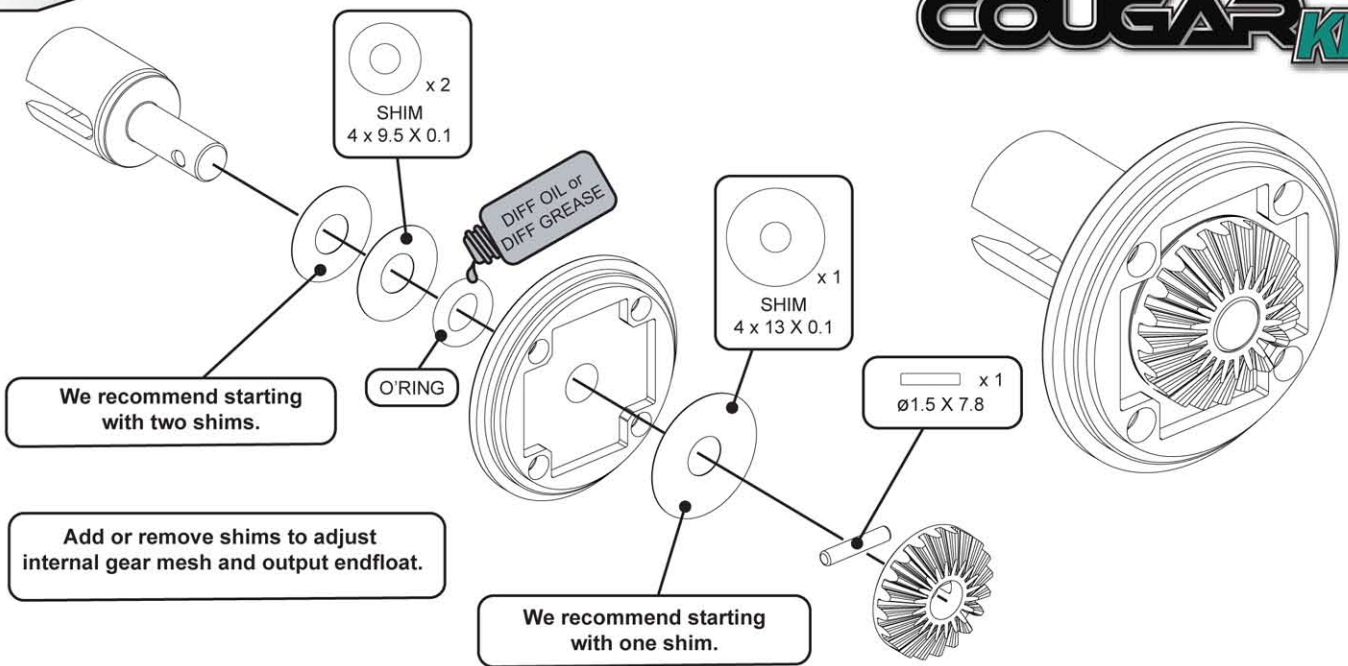

Step 25 A

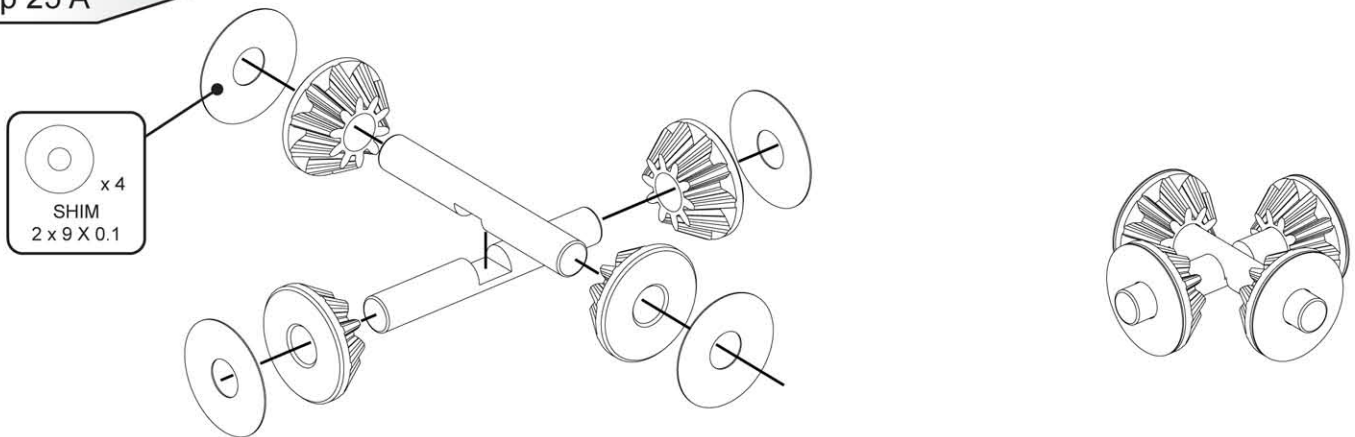

Step 25 B

**Check the internal gear mesh of the diff.**

1. If too loose add an internal shim, (step 23 or 24) and remove an output shim. (There should be three shims in total)
2. If too tight remove an internal shim, (step 23 or 24) and add an output shim. (There should be three shims in total)

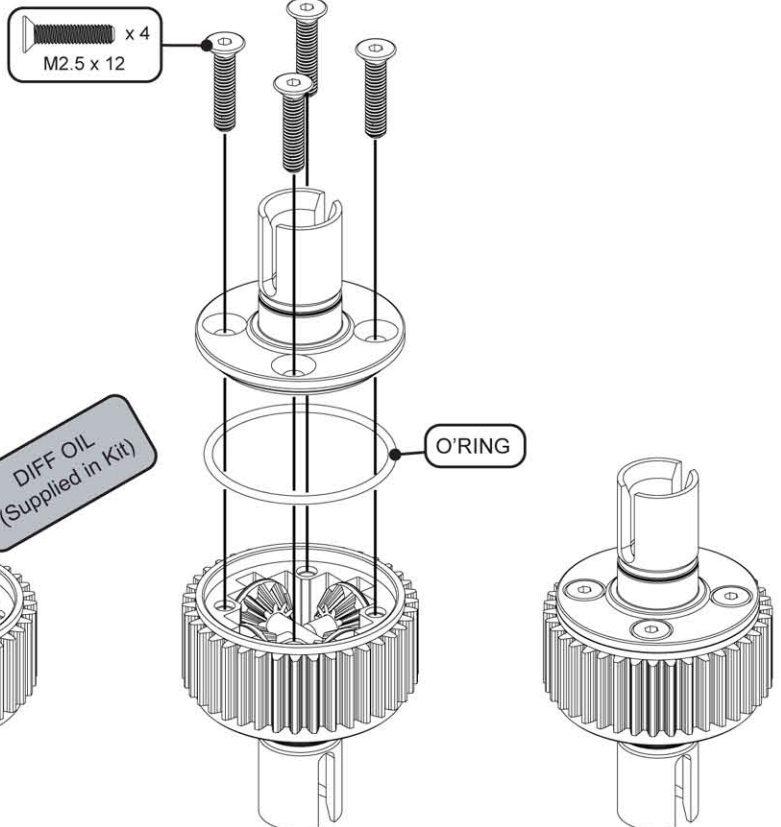

Fill with diff oil to just cover the pins.

DIFF OIL (Supplied in Kit)



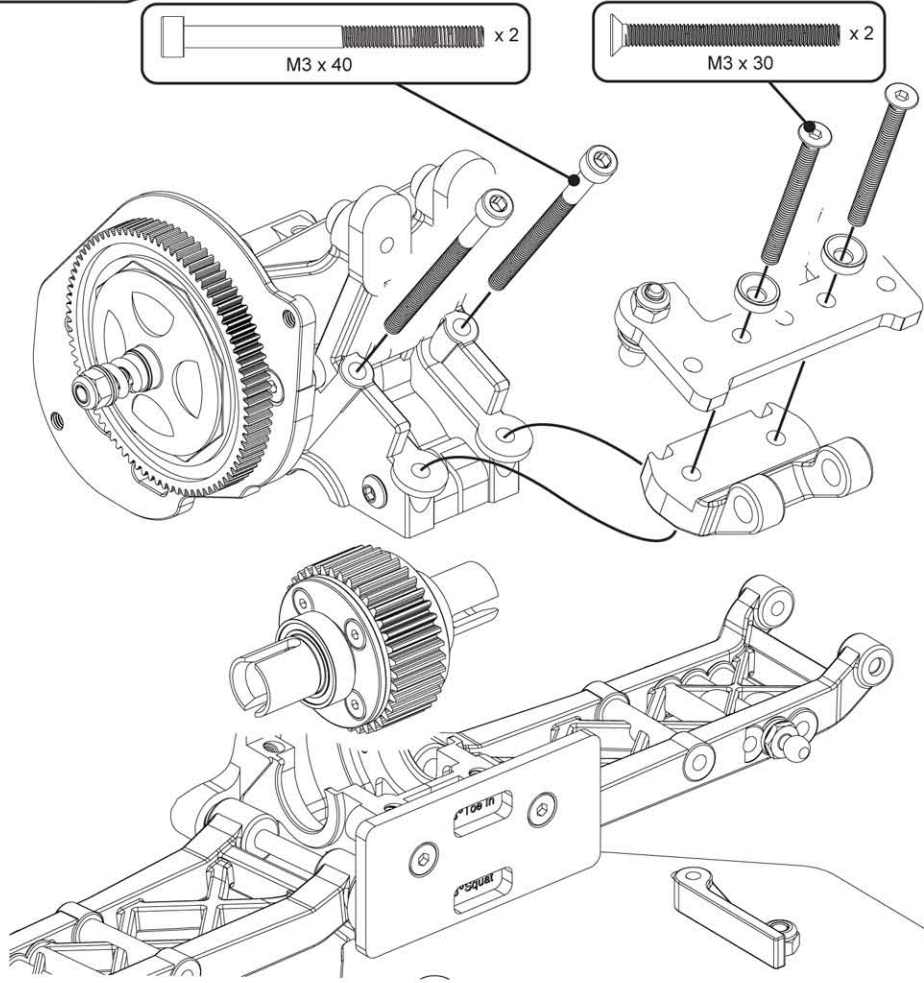
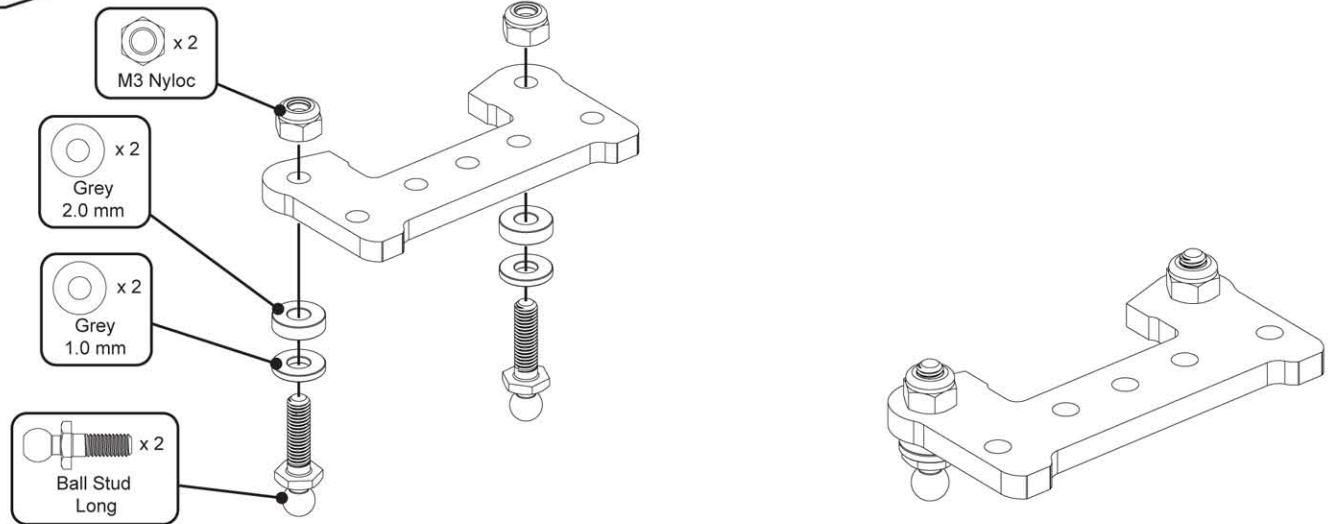
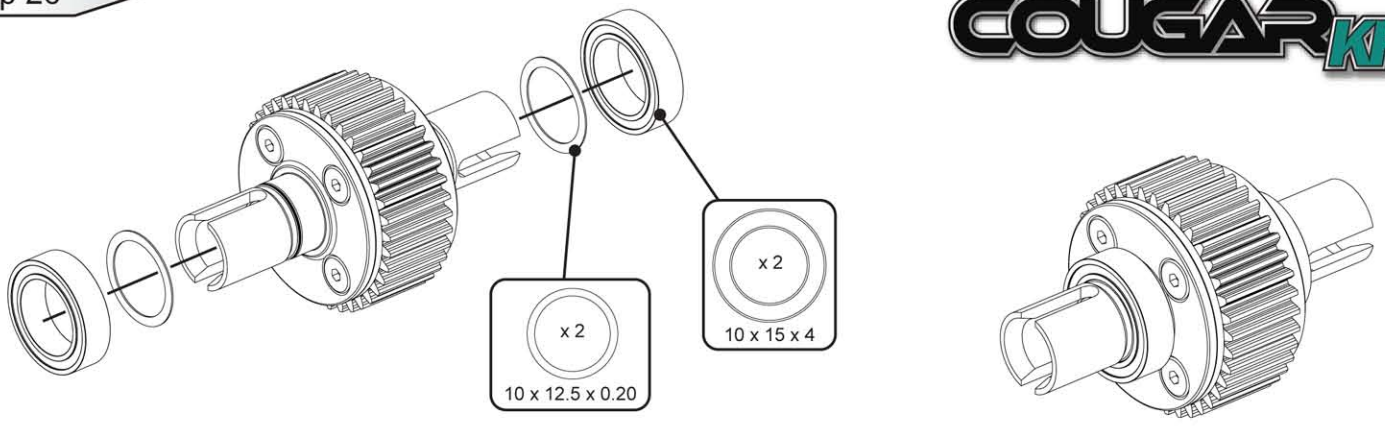

**CAUTION**  
Do not overtighten.  
Ensure all four screws are tightened equally.

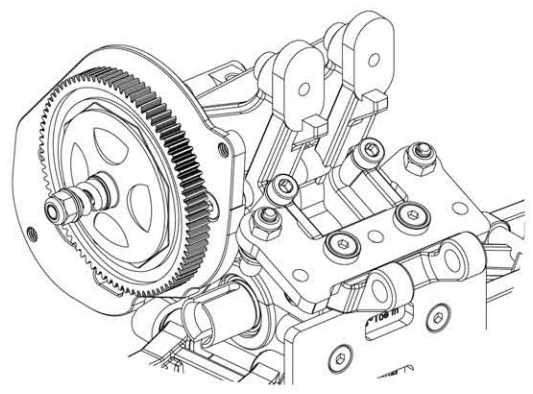

Step 29 A

**REAR PIN ONLY**  
Do not use  
the Dia. 1.50 pins from  
the front hex.

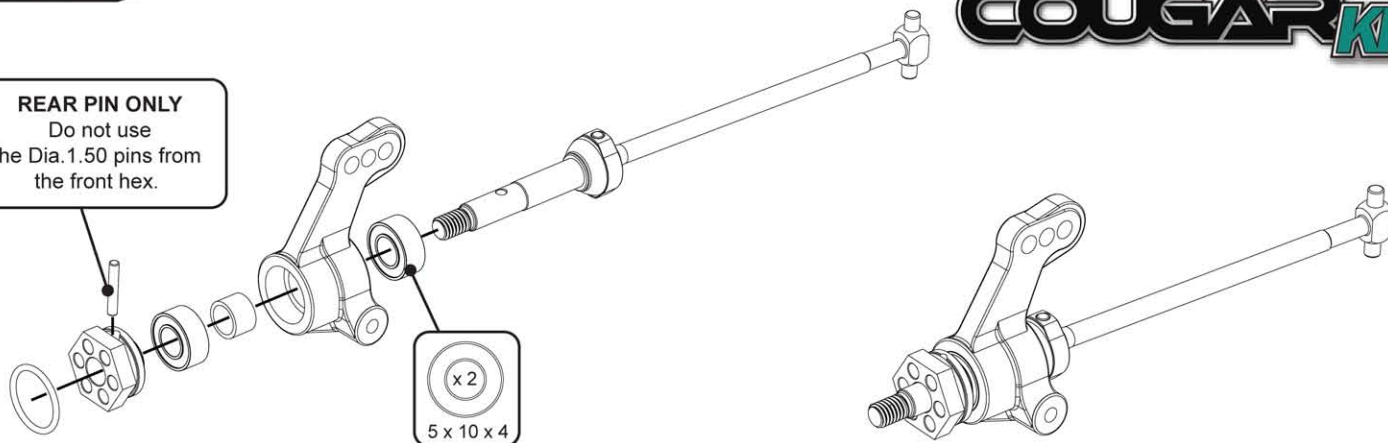

Step 29 B

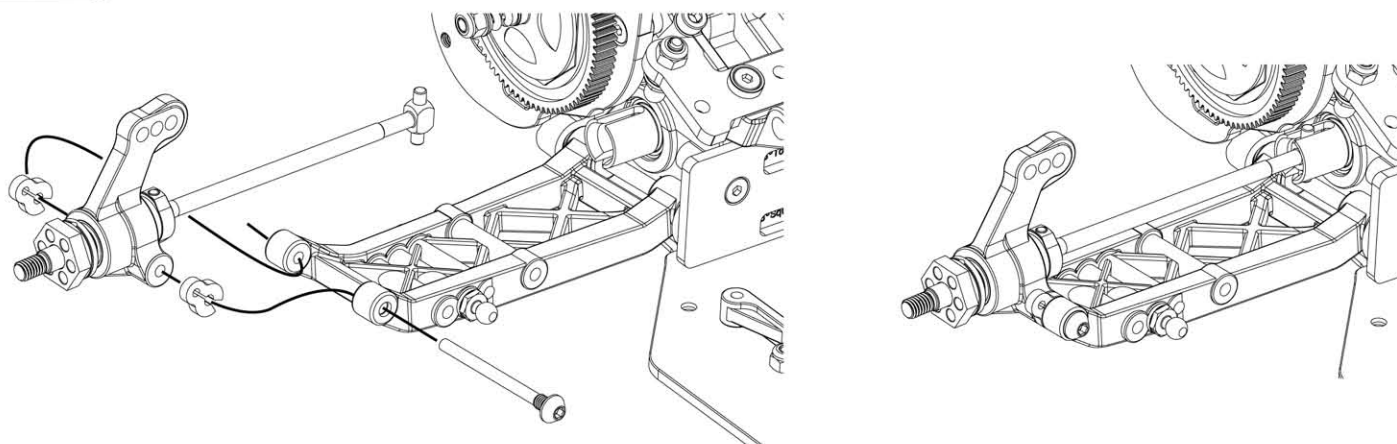

Step 30 A

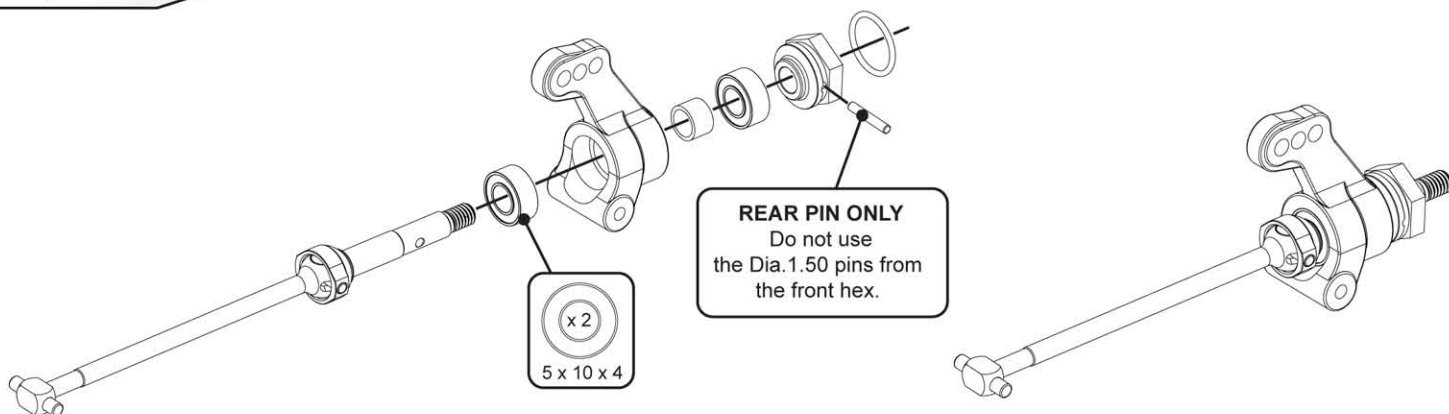

Step 30 B

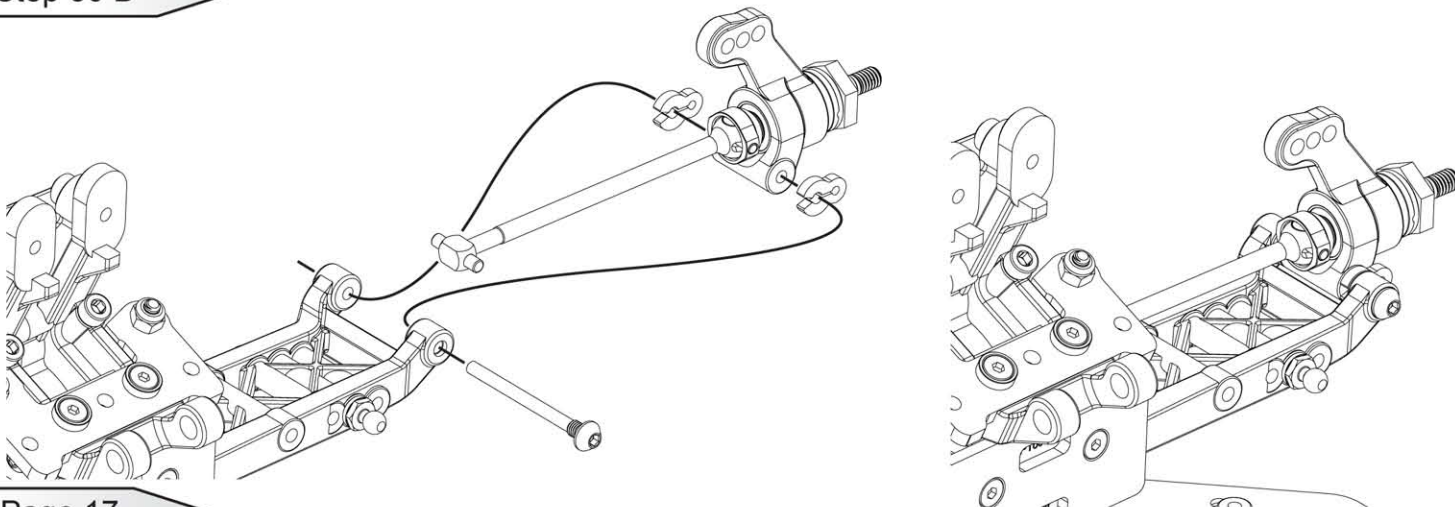

### Step 31 A

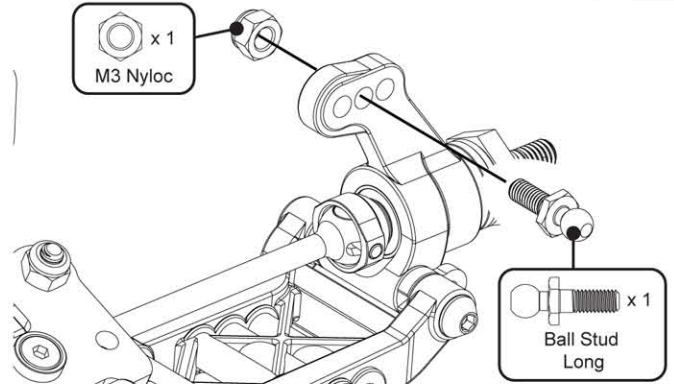
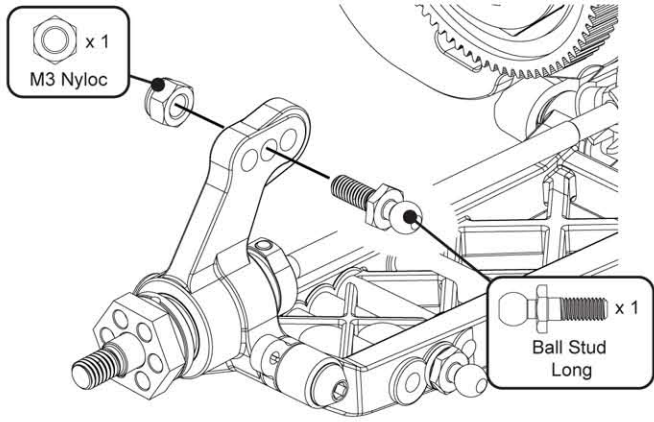

### Step 31 B

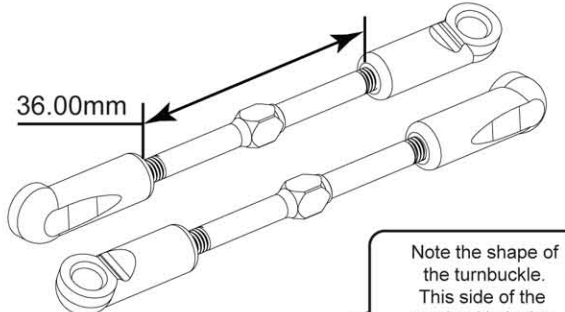
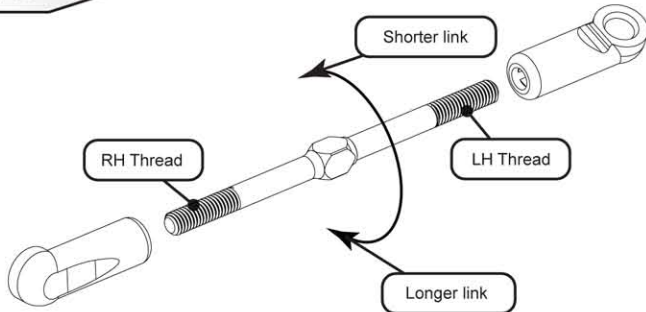

Carefully screw the sockets onto the turnbuckle until no threads are visible. Then undo them to the desired length. This allows for easier adjustment on the car. (Greasing the threads will also help)

Note the shape of the turnbuckle. This side of the turnbuckle is the left hand thread.

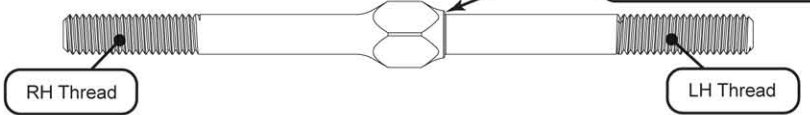

### Step 31 C

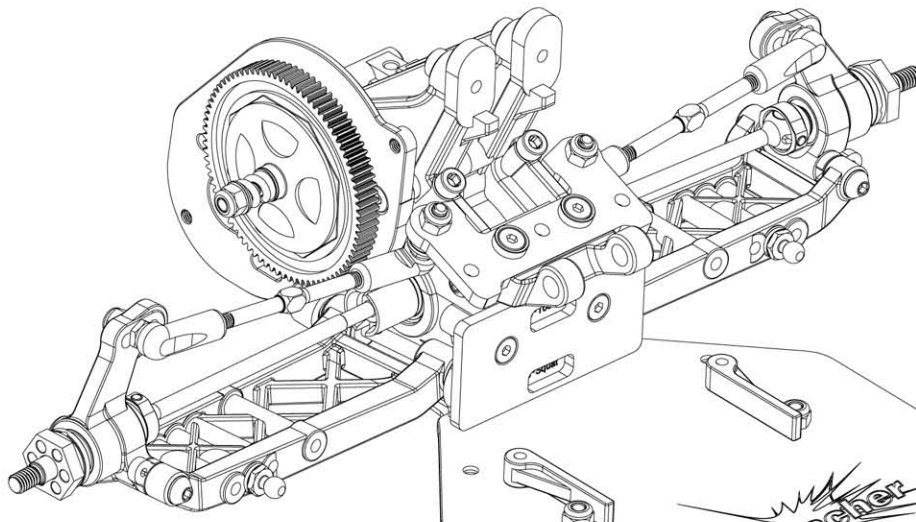
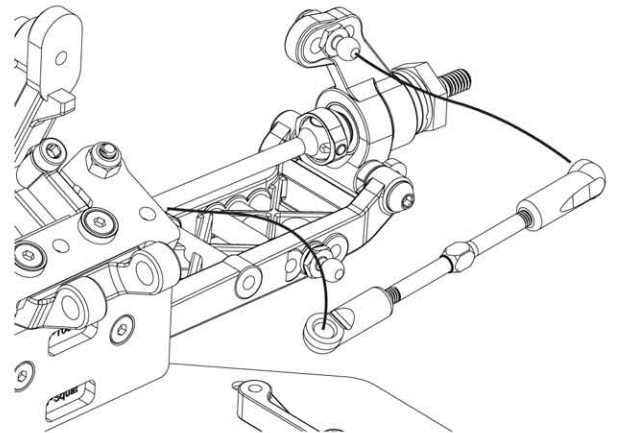
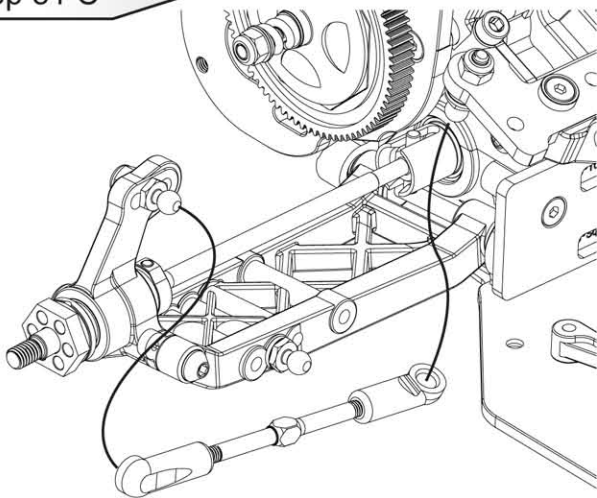

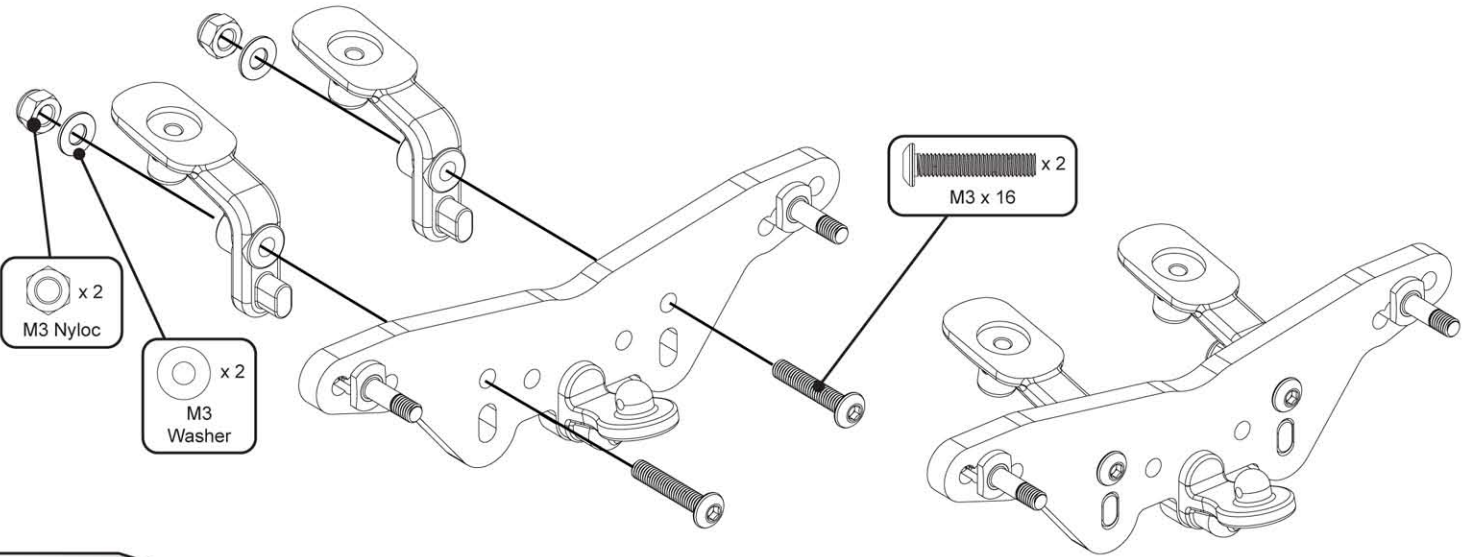
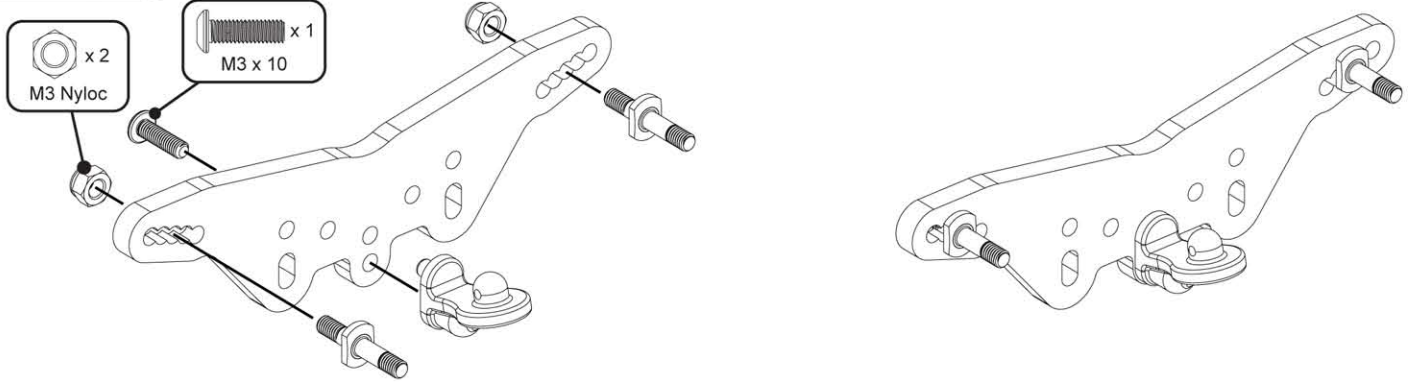
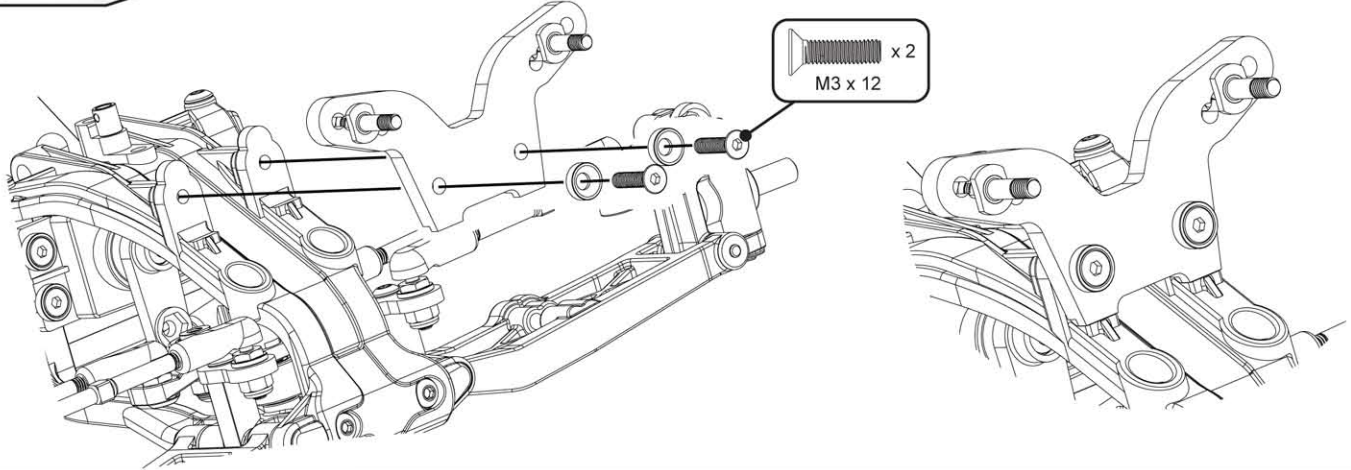
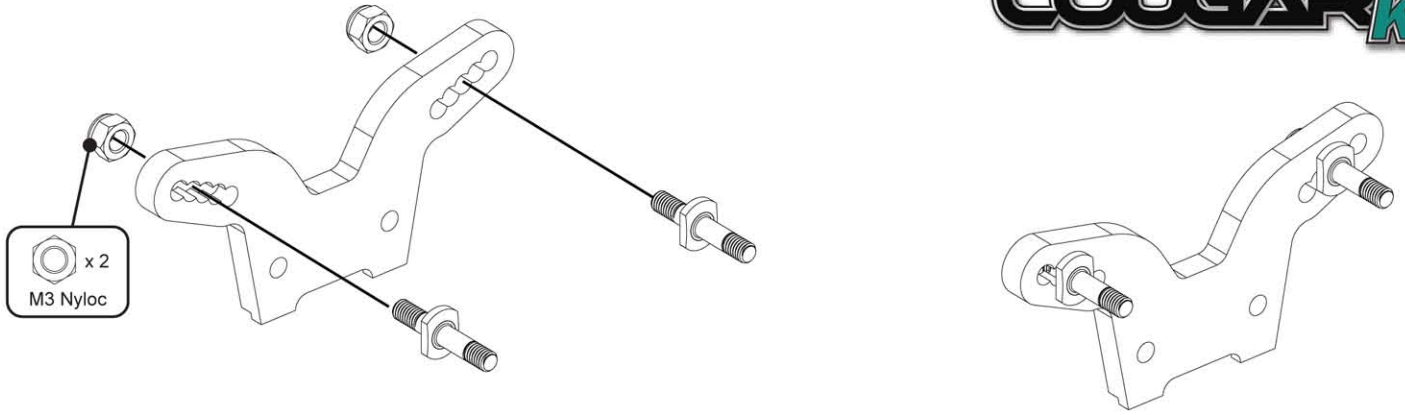

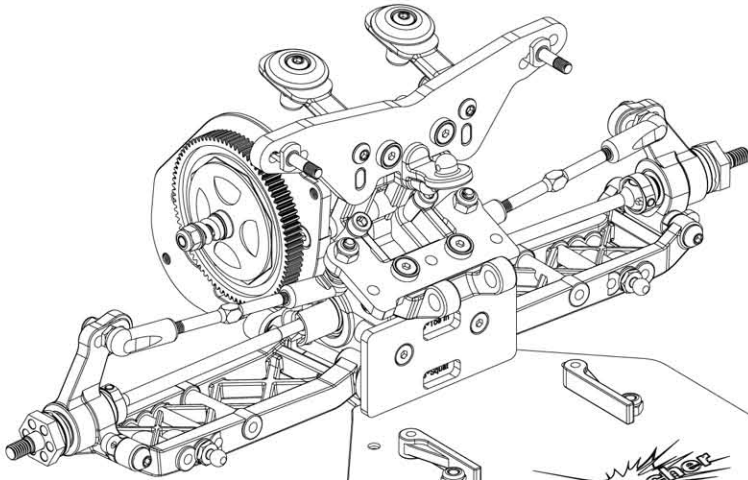
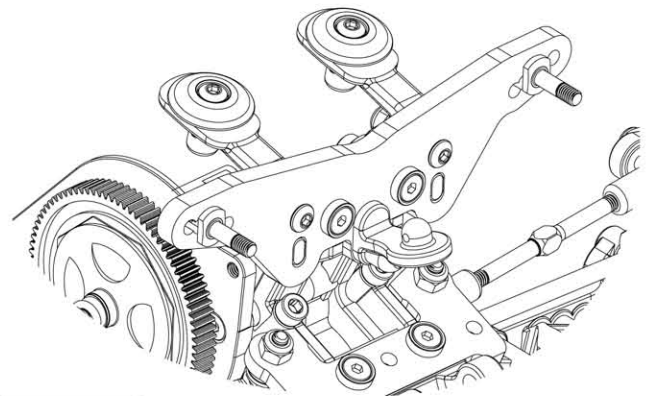
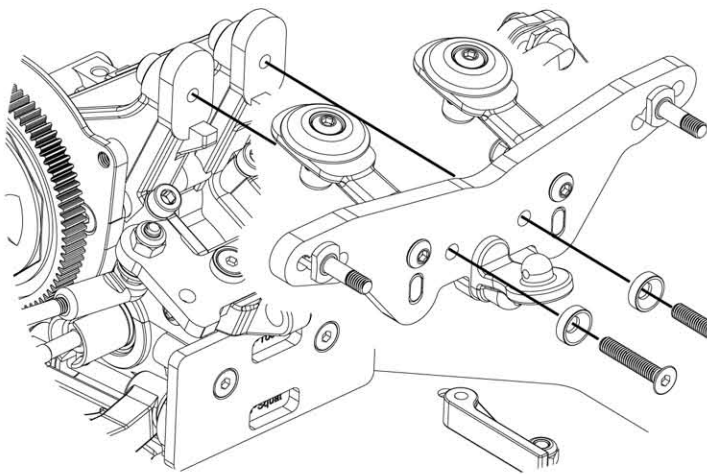
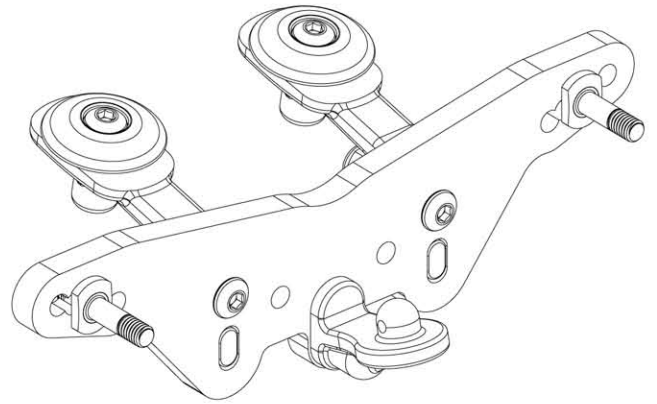
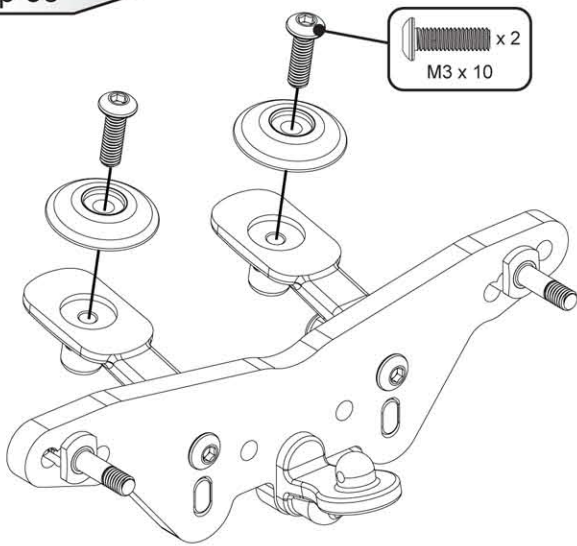

x 2  
M3 x 16

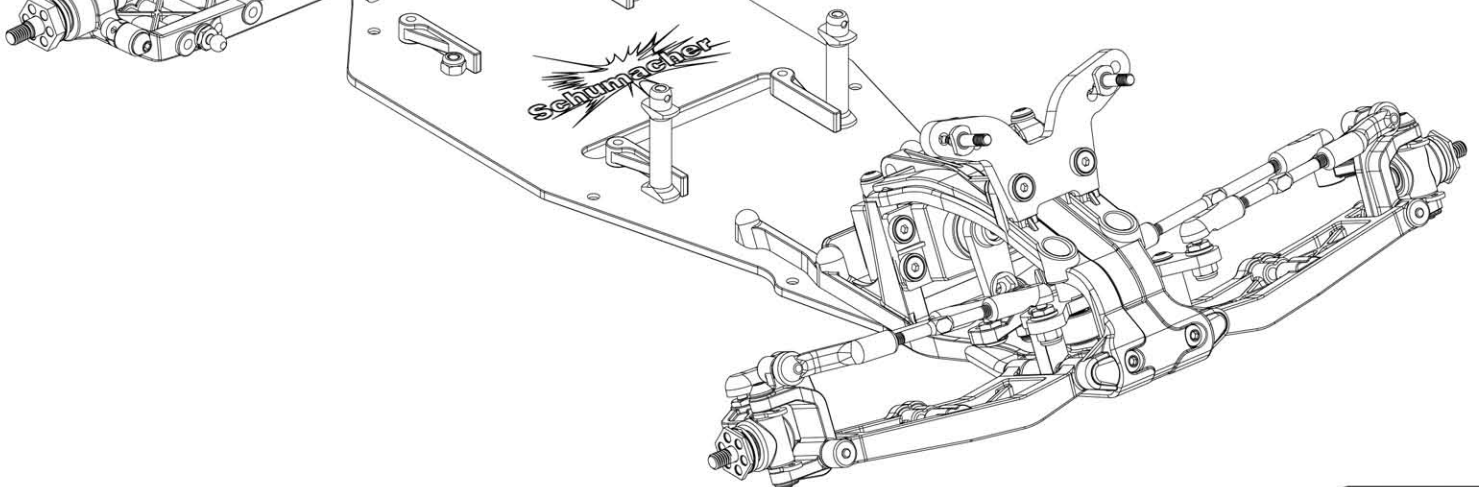

**KITS**

K139 Cougar KR - Kit  
K140 Cougar KR - Assembled

**BODYSHELLS AND DECALS**

U4372 Decals - Cougar KR - pk3  
U5113 Wing Talon Off Road - White  
U5114 Wing Talon Off Road - Black  
U5115 Wing Talon Off Road - Carbon Look  
U5117 Talon Wing Clear - CAT K1  
U5118 Bodyshell + Decal + Window Mask - Cougar KR

**CHASSIS PARTS**

U1042 Aerial Mount - Universal  
U119 Aerial Tube - pk 4  
U122 Velcro 500mmx16mm.  
U2231 Servo Horns  
U3690 Front Bumper - Cougar SV  
U3691 Servo Spacer - Cougar SV  
U4070 Alloy Chassis - Cougar SVR  
U4075 Lipo Stop - Cougar SVR - pk4  
U4086 Lipo positioning foam block - SVR  
U4092 Side Pods - Cougar SVR  
U4093 Bottom Plate - Cougar SVR  
U4105 Body Mount Rear - SVR  
U4145 LiPo Posts; Alloy - CAT K1 - pr  
U4373 Instruction Manual - Cougar KR  
U4374 C/F Top Deck (kit) - Cougar KR  
U4376 Top Deck Mouldings - Cougar KR  
U4377 Wing Mount Set (Low) - Cougar KR  
U4378 Skid Plate - Cougar KR  
U4379 Top Deck Pivot - Cougar KR

**TRANSMISSION**

CR024 CORE RC - Serrated M4 Steel Wheel Nut - pk4  
U2761 Diff Shims; 10x12 - pk8  
U3311 Axle Spacers - 2prs  
U3351 Gear; 83t Spur - Slipper  
U3364 Slipper Pad; PTFE Octagon - pr  
U3834 Driveshaft; Pivot; Pin; Screw - Mi4CX  
U3869 Slipper Set - CAT SX3 - pr  
U4037 Idler Gear + Shaft - Cougar SV2  
U4069 Driveshaft Assembled - Cougar SVR - pr  
U4071 Motor Plate - Cougar SVR  
U4072 Layshaft - Cougar SVR  
U4073 Trans Lower RH - Cougar SVR  
U4074 Trans Lower LH - Cougar SVR  
U4076 Motor Guard - Cougar SVR  
U4077 Trans Upper LH & RH - Cougar SVR  
U4083 Slipper Spacer - Cougar SVR  
U4087 Axle Rear - Cougar SVR  
U4088 Bone Rear - Cougar SVR  
U4089 Blanking Plug - Cougar SVR  
U4091 Gear Cover & Plug - Cougar SVR  
U4106 Slipper Spring  
U4124 Speed Pack - Shims 5 x 7 x 0.4mm - pk6  
U4176 Gear Diff Gear Set - CAT K1  
U4352 Gear Diff - SVR  
U4385 Gear Diff Rebuild Kit - Cougar KR  
U4386 Gear Diff Output - Cougar KR  
U4387 Gear Diff Mouldings - Cougar KR  
U4388 Alloy Wheel Hex Rear - Off Road - pr  
U4390 Drive Pins 1.6mm - Off Road - pk8

**SUSPENSION**

U2722 Ball Grippa Joints - U/Sh Stud - 4pr  
U2989 Ball Grippa Sockets - pk8  
U3137 Shock Mounting Post - pr  
U3479 Ball Grippa Sockets-Short - pk8  
U3495 Ball Studs; Ultra Short - pk 4  
U3496 Ball Studs; Short - pk 4  
U3497 Ball Studs; Long - pk 4  
U3498 Ball Studs; X-Long - pk 4  
U3706 Rod End Ball + Socket - Cougar SV2 - pr  
U3708 Kwik Clip 2.4mm - Cougar SV - pk4  
U3709 Radius Arms - Cougar SV  
U3710 Centre Track Rod - Cougar SV  
U3712 Yokes; 0 deg - Cougar SV  
U3715 Pivot Pin; Screw Type 25mm - pr  
U3716 Pivot Pin; Screw Type 32mm - pr  
U3717 Steering Pivots - Cougar SV - pk4  
U3718 Pivot Pin; 38mm - Cougar SV  
U3719 Pivot Pin; 45mm - Cougar SV  
U3729 Wishbone Pivot Spheres - Cougar SV - pk4  
U3997 C/F Front Shock Mount - Cougar SV2  
U4031 Front Body Post - Cougar SV2  
U4036 Hub Carrier; Rear - Cat/Cougar SV2 - pr  
U4055 Wishbones; Rear Kit - Cougar SV2  
U4078 C/F Shock Mount Rear 4mm - Cougar SVR  
U4090 Ball Socket; Offset - Cougar SVR - pk4

**SUSPENSION Cont...**

U4094 Bulkhead - Cougar SVR  
U4095 Wishbones Front - Long (pair) - SVR  
U4223 Turnbuckle Adjuster HTT - 45mm - pr  
U4224 Turnbuckle Adjuster HTT - 60mm - pr  
U4299 Turnbuckle HT - Touring 52mm - pr  
U4380 Front Hub Carriers - Cougar KR - pr  
U4381 Kwik Clip 2.4mm thin - Cougar KR - pk4  
U4382 Front Axle - Cougar KR  
U4383 Alloy Rear Strap 3Deg - Cougar KR  
U4384 C/F Rear Suspension Pin Retainer - Cougar KR  
U4389 Alloy Wheel Hex Front - 2WD - pr  
U4391 C/F Link Mounts; Kit Fr + Rr - Cougar KR  
U750 Ball Grippa Joints - Short Stud - 8pr  
U851 Ball Grippa Joints - Long Stud - 8pr

**BEARINGS AND BALLS**

G200 ZX1 - Microlube  
U1300 Axle Grease - Pot  
U1301 Silicone Diff Lube - Pot  
U1957 Moly Grease - Pot  
U2698 Ball Bearing - 5x10x4 Red Sealed - pr  
U2699 Ball Bearing - 10x15x4 Red Sealed - pr  
U3075 Ball Bearing 4x8x3mm Red Sealed - pr  
U3136 Ball Bearing - 5x8x2.5 - Shielded - pr  
U3871 Ball Bearing 5x9x3 Red Seal - pr  
U4084 Ball Bearing - 6x12x4 Red Sealed - pr

**BIG BORE SHOCKS**

U3662 Big Bore Shock Body; Med - pr  
U3663 Big Bore Shock Body; Long - pr  
U3667 Big Bore Shock Seal Rebuild Kit - Off Rd - pr  
U3668 Big Bore Shock Rods; Med - pr  
U3669 Big Bore Shock Rods; Long - pr  
U3670 Big Bore Shock 2 Hole Pistons - pr  
U3671 Big Bore Shock 4 Hole Pistons - pr  
U3672 Big Bore Shock 6 Hole Pistons - pr  
U3770 Big Bore Rounded Pistons 3 Hole - pr  
U3771 Big Bore Rounded Pistons 5 Hole - pr  
U3937 Shock Mouldings  
U4110 Off Road Shock O-Ring 1/8 Silicone - pk8  
U4369 Big Bore Seal Pack Housing (Black) - pr  
U4370 Big Bore Shock cap (Black) - pr  
U4371 Big Bore Shock Adjusting Collar (Black) - pr  
U4392 Big Bore Shocks; Front - Assembled - pr  
U4393 Big Bore Shocks; Rear - Assembled - pr

**CORE BIG BORE SPRINGS**

CR177 CORE RC Big Bore Spring Tuning Set; Med - 5pr  
CR178 CORE RC Big Bore Spring Tuning Set; Long - 5pr  
CR179 CORE RC Big Bore Spring; Med - 2.8 - pr  
CR180 CORE RC Big Bore Spring; Med - 3.1 - pr  
CR181 CORE RC Big Bore Spring; Med - 3.4 - pr  
CR182 CORE RC Big Bore Spring; Med - 3.7 - pr  
CR183 CORE RC Big Bore Spring; Med - 4.0 - pr  
CR184 CORE RC Big Bore Spring; Long - 1.8 - pr  
CR185 CORE RC Big Bore Spring; Long - 2.0 - pr  
CR186 CORE RC Big Bore Spring; Long - 2.2 - pr  
CR187 CORE RC Big Bore Spring; Long - 2.4 - pr  
CR188 CORE RC Big Bore Spring; Long - 2.6 - pr  
CR190 CORE RC Spring Seat - Big Bore to 13mm - pk4  
CR191 CORE RC Spring Seat - Big Bore to 14mm - pk4

**BIG BORE SPRINGS**

U3673 Big Bore Spring Tuning Set; Med - 7pr  
U3674 Big Bore Spring Tuning Set; Long - 6pr  
U3675 Big Bore Spring; Med - 2.0 - pr  
U3676 Big Bore Spring; Med - 2.5 - pr  
U3677 Big Bore Spring; Med - 3.0 - pr  
U3678 Big Bore Spring; Med - 3.5 - pr  
U3679 Big Bore Spring; Med - 4.0 - pr  
U3680 Big Bore Spring; Med - 4.5 - pr  
U3681 Big Bore Spring; Med - 5.0 - pr  
U3682 Big Bore Spring; Long - 1.6 - pr  
U3683 Big Bore Spring; Long - 2.0 - pr  
U3684 Big Bore Spring; Long - 2.5 - pr  
U3685 Big Bore Spring; Long - 3.0 - pr  
U3686 Big Bore Spring; Long - 3.5 - pr  
U3687 Big Bore Spring; Long - 4.0 - pr

**SHOCK AND DIFF OIL**

CR200 CORE RC Silicone Oil - 100cSt - 60ml  
CR201 CORE RC Silicone Oil - 150cSt - 60ml  
CR202 CORE RC Silicone Oil - 200cSt - 60ml  
CR203 CORE RC Silicone Oil - 250cSt - 60ml  
CR204 CORE RC Silicone Oil - 300cSt - 60ml  
CR205 CORE RC Silicone Oil - 350cSt - 60ml  
CR206 CORE RC Silicone Oil - 400cSt - 60ml  
CR207 CORE RC Silicone Oil - 450cSt - 60ml  
CR208 CORE RC Silicone Oil - 500cSt - 60ml

**SHOCK AND DIFF OIL Cont....**

CR209	CORE RC Silicone Oil - 550cSt - 60ml
CR210	CORE RC Silicone Oil - 600cSt - 60ml
CR211	CORE RC Silicone Oil - 700cSt - 60ml
CR212	CORE RC Silicone Oil - 800cSt - 60ml
CR213	CORE RC Silicone Oil - 900cSt - 60ml
CR214	CORE RC Silicone Oil - 1000cSt - 60ml
CR215	CORE RC Silicone Oil - 1300cSt - 60ml
CR216	CORE RC Silicone Oil - 2000cSt - 60ml
CR217	CORE RC Silicone Oil - 3000cSt - 60ml
CR218	CORE RC Silicone Oil - 4000cSt - 60ml
CR219	CORE RC Silicone Oil - 5000cSt - 60ml
CR220	CORE RC Silicone Oil - 6000cSt - 60ml
CR221	CORE RC Silicone Oil - 7000cSt - 60ml
CR222	CORE RC Silicone Oil - 10000cSt - 60ml
CR223	CORE RC Silicone Oil - 20000cSt - 60ml
CR224	CORE RC Silicone Oil - 30000cSt - 60ml
CR225	CORE RC Silicone Oil - 40000cSt - 60ml
CR226	CORE RC Silicone Oil - 50000cSt - 60ml
CR227	CORE RC Silicone Oil - 100000cSt - 60ml
CR228	CORE RC Silicone Oil - 300000cSt - 60ml
CR229	CORE RC Silicone Oil - 12000cSt - 60ml
CR230	CORE RC Silicone Oil - 15000cSt - 60ml
G010	Pure Silicone Shock Oil - 10w
G015	Pure Silicone Shock Oil - 15w
G020	Pure Silicone Shock Oil - 20w
G025	Pure Silicone Shock Oil - 25w
G030	Pure Silicone Shock Oil - 30w
G035	Pure Silicone Shock Oil - 35w
G040	Pure Silicone Shock Oil - 40w
G045	Pure Silicone Shock Oil - 45w
G050	Pure Silicone Shock Oil - 50w

**SPEED PACKS**

U1544	SPEED PACK - Short M3; Cap Hd
U1545	SPEED PACK - M3 Cap Hd 16;20mm
U1546	SPEED PACK - M3 Cap Hd 25;30;35;40;45mm
U1547	SPEED PACK - M3 Nuts
U1548	SPEED PACK - M3 Washers
U1550	SPEED PACK - Socket Wrenches - pk3
U1551	SPEED PACK - E Clips - 8pcs
U1552	SPEED PACK - R Clips
U1606	SPEED PACK - Servo Tape - 30pk
U1633	SPEED PACK - Small Pins
U1960	SPEED PACK - O-Rings; Various
U2128	SPEED PACK - Grub-Set Screws M3 M4
U2356	SPEED PACK - M3x16-30 Csk Screws - pk12
U2760	SPEED PACK - M3 Button Hd; 4 to 20
U2856	SPEED PACK - Sticky Cable Clips - pk10
U2858	SPEED PACK - Alloy M3x6 Spacers - 0.5, 1, 2 & 3mm (Purple) - 16pc
U2988	SPEED PACK - M3 Csk Washers - Purple Alloy - pk10
U3021	SPEED PACK - M3x6 Csk Allen Hi-T
U3022	SPEED PACK - M3x8 Csk Allen Hi-T
U3023	SPEED PACK - M3x10 Csk Allen Hi-T
U3024	SPEED PACK - M3x12 Csk - M3 x 10 Button Screws
U3131	SPEED PACK - Alloy Spacers M3x7mm 0.5;1;2mm - pk18
U3572	SPEED PACK - M3x14 Grub Srew - pk4
U3754	SPEED PACK - M2.5x10 Csk Hd - pk8
U4155	SPEED PACK - M3 Csk Washers - Black Alloy - pk10
U4210	SPEED PACK - Pinion Grub Screw Set - pk10
U4230	SPEED PACK - M3 x 6mm Alloy Button Head Screws - pk10
U4231	SPEED PACK - M3 x 8mm Alloy Button Head Screws - pk10
U4232	SPEED PACK - M3 x 10mm Alloy Button Head Screws - pk10
U4233	SPEED PACK - M3 x 12mm Alloy Button Head Screws - pk10
U4234	SPEED PACK - M3 x 6mm Alloy Csk Screws - pk10
U4235	SPEED PACK - M3 x 8mm Alloy Csk Screws - pk10
U4236	SPEED PACK - M3 x 10mm Alloy Csk Screws - pk10
U4237	SPEED PACK - M3 x 12mm Alloy Csk Screws - pk10
U4238	SPEED PACK - M3 x 16mm Alloy Csk Screws - pk10
U4241	SPEED PACK - M3 Alloy Nyloc Nuts - Black - pk10
U4314	SPEED PACK - Alloy Black Washers - Mi5 - 16pc
U4351	SPEED PACK - Shims 3.2x6x0.1mm - pk8

**SPEED SECRET - OPTION PARTS**

CR035	CORE RC - Serrated Alloy M4 Nuts; Blue - pk4
CR036	CORE RC - Serrated Alloy M4 Nuts; Purple - pk4
CR043	CORE RC - Silver X-Weights - 16pc
CR058	CORE RC - Black X-Weights - 16pc
CR192	Alloy Servo Arm 25T - Futaba Short (Black)
CR193	Alloy Servo Arm 23T - Sanwa Short (Black)
CR196	CORE RC - Serrated Alloy M4 Nuts; Black - pk4
MR-CSOFFROAD	MR33 Car Stand Off Road
S500B	Schumacher BANNER 6x3ft
U1573	Titanium Turnbuckle; purple - 53mm - pr
U1574	Titanium Turnbuckle; purple - 60mm - pr
U1954	Pro - Thrust Bearing
U2566	Titanium Turnbuckle - 45mm - pr
U2999	Small Bore Shock Seal Rebuild Kit
U3019	Diff Balls; Ceramic Nitride 2.5mm - pk12
U3317	Small Bore Shock Body (Front) - Off Road - pr
U3318	Small Bore Shock Body (Rear) - Off Road - pr
U3319	Small Bore Piston 2 Hole (CNC) - Off Road - pr

**SPEED SECRET - OPTION PARTS Cont....**

U3320	Small Bore Piston 3 Hole (CNC) - Off Road - pr
U3321	Small Bore Shock Rod (Front) - Off Road - pr
U3322	Small Bore Shock Rod (Rear) - Off Road - pr
U3323	Small Bore Shock Seal Hsg (Black) - Off Road - pr
U3324	Small Bore Shock Top Cap (Purple) - Off Road - pr
U3348	Gear; CNC 80t Spur - Slipper
U3349	Gear; CNC 81t Spur - Slipper
U3350	Gear; CNC 82t Spur - Slipper
U3499	Roll Bar Blocks - Mi4 - pk4
U3605	Alloy Rear Hubs; 1 deg - CAT/Cougar SV - pr
U3611	Alloy Spring Seat - All shock types - pr
U3664	Big Bore Shock Cap (Purple); Off Road - pr
U3665	Big Bore Shock Seal Housing (Purple) - pr
U3666	Big Bore Shock Adjusting Collar (Gold) - pr
U3740	Diff Washers; 18mm - Cougar SV
U3758	Yokes; 5 deg - Cougar SV
U3782	HD Diaphragm - pk4
U3790	Gear; CNC 76T Spur - Slipper
U3827	C/F Lowered Front Shock Mount 4mm - Cougar
U3855	Ball Bearing 5x10x3 Open - pr
U4004	Diff Gear; 38T CNC - Cougar SV2
U4005	Diff Output; Female - Cougar SV2
U4006	Diff Output; Male - Cougar SV2
U4007	Diff; Assembled Pro Spec - Cougar SV2
U4025	Driveshaft UJ - Cougar SV2 - pr
U4040	Ball Diff Screw Set Cougar SV2
U4054	Wishbones Rear Medium - Cougar SV2
U4081	C/F Strap 0deg antisquat - 3deg Toe-in - SVR
U4085	Rear Anti Roll Bar Set - Cougar SVR
U4096	C/F Strap 1deg antisquat - 3deg Toe-in - SVR
U4097	C/F Strap 2deg antisquat - 3deg Toe-in - SVR
U4098	Wishbones Front - Long Med Flex - SVR - pr
U4099	C/F Chassis 2.5mm soft +6mm - SVR
U4125	Small Bore Taper Piston 1.2mm - White - pr
U4126	Small Bore Taper Piston 1.3mm - Black - pr
U4127	Small Bore Taper Piston 1.4mm - Red - pr
U4130	Vented Shock Caps - Small Bore - pr
U4149	Small Bore Adjuster (Big Bore Springs) - CAT K1 (pr)
U4150	Small Bore Shock Seal Hsg (Black) - Off Road - pr
U4151	Small Bore Shock Top Cap (Black) - Off Road pr
U4152	Small Bore Shocks (Front) - Assembled
U4153	Small Bore Shocks (Rear) - Assembled
U4209	Vented Shock Caps - Big Bore - pr
U4211	C/F Strap 0deg antisquat - 2deg Toe-In - SVR
U4212	C/F Strap 1deg antisquat - 2deg Toe-In - SVR
U4213	C/F Strap 2deg antisquat - 2deg Toe-In - SVR
U4214	C/F Strap 3deg antisquat - 2deg Toe-In - SVR
U4226	Gear; CNC 71T Spur - Slipper
U4228	Alloy Yokes (Black) - 2WD - 5deg - Cougar
U4273	Pro Ball Stud Ultra Short - pk4
U4274	Pro Ball Stud Short - pk4
U4275	Pro Ball Stud Long - pk4
U4285	Pro Shock Seal Blue - On Road - pk8
U4317	Wide Track Conversion - Cougar SV2/SVR
U4375	C/F Top Deck (+6mm) - Cougar KR
U4394	C/F Link Mount Options; Fr + Rr Cougar KR Set5

**1-10 BUGGY WHEELS**

U4365	Wheel Hex Front - (black) - Off Road - pr
U4366	Wheel Hex Front - (white) - Off Road - pr
U4367	Wheel Hex Front - (black) - 2wd - pr
U4368	Wheel Hex Front - (white) - 2wd - pr

**1-10 BUGGY OFF ROAD TYRES**

CR143	Multi Bow; 1/10 Off Rd Rear
CR144	Multi Bow; 1/10 Off Rd 4WD Front
CR145	Multi Block; 1/10 Off Rd Rear
CR146	Multi Block; 1/10 Off Rd 4WD Front
T650	Full Spike - Rear Tyres - Soft CAT (pr)
T652	Full Spike - Front Tyres - Soft CAT (pr)
T692	Block - Rear Tyres - Blue - CAT (pr)
T693	Block - Front Tyres - Blue - CAT (pr)
U6515	Mini Spike 2; Front Tyres - Green - 2.2 (pr)
U6516	Mini Spike 2; Rear Tyres - Green - 2.2 (pr)
U6517	Mini Spike 2; Front Tyres - Blue - 2.2 (pr)
U6518	Mini Spike 2; Rear Tyres - Blue - 2.2 (pr)
U6549	Mini Spike 2; Blue - Slim (pr)
U6550	Mini Spike 2; Green - Slim (pr)
U6557	Mini Spike 2; Front Tyres - Yellow (pr)
U6558	Mini Spike 2; Rear Tyres - Yellow (pr)
U6581	Mini Spike 2; standard -Yellow - Slim (pr)
U6592	Stagger Rib - Yellow - Slim
U6595	Full Spike - Front Tyres - Yellow - 2.2 (pr)
U6596	Full Spike - Rear Tyres - Yellow - 2.2 (pr)
U6601	Mini Pin - Blue - Front - 2.2 (pr)
U6602	Mini Pin - Blue - Rear - 2.2 (pr)
U6607	Mini Pin - Yellow - Front - 2.2 (pr)
U6608	Mini Pin - Yellow - Rear - 2.2 (pr)

**1-10 BUGGY OFF ROAD TYRES Cont....**

U6609	Mini Pin - Yellow - Slim (pr)
U6759	Cut Stagger - Yellow - Slim (pr)
U6761	Mini Spike 2; Silver - Slim (pr)
U6762	Mini Spike 2; Front Tyres - Silver (pr)
U6763	Mini Spike 2; Rear Tyres - Silver (pr)
U6765	Cut Stagger Green - Slim (pr)
U6770	Cut Stagger - Low Profile - Yellow (pr)
U6771	Cut Stagger - Low Profile - Green (pr)
U6775	Cut Stagger - Low Profile - Silver (pr)
U6776	Cut Stagger - Low Profile - Blue (pr)
U6778	Mini Pin - Silver - Rear - 2.2 (pr)
U6779	Mini Pin - Silver - Slim (pr)
U6786	Block - Rear Tyres - Yellow - CAT pr

**1-10 INSERTS**

CR141	Red Moulded Insert; 1/10 Off Rd Rear
CR142	Red Moulded Insert; 1/10 Off Rd 4WD Front
U6652	Foam Tyre Insert; Hard - Front - CAT (pr)
U6653	Foam Tyre Insert; Hard - Rear - CAT (pr)
U6667	Foam Tyre Insert; Hard - Slim 2WD (pr)
U6668	Foam Tyre Inserts; Soft - Ultra Wide (pr)
U6669	Foam Tyre Inserts; Hard - Ultra Wide (pr)
U6733	Foam Tyre Insert; Med - Front - CAT (pr)
U6734	Foam Tyre Insert; Med - Rear - CAT (pr)
U6738	Foam Tyre Insert; Med - Slim 2WD (pr)
U6746	Tubby Insert; Med Front - CAT (pr)
U6747	Tubby Insert; Med Rear - CAT (pr)

**PINIIONS**

U2305	16T Steel Pinion - 48 D.P.
U2306	17T Steel Pinion - 48 D.P.
U2307	18T Steel Pinion - 48 D.P.
U2308	19T Steel Pinion - 48 D.P.
U2309	20T Steel Pinion - 48 D.P.
U2310	21T Steel Pinion - 48 D.P.
U2311	22T Steel Pinion - 48 D.P.
U2312	23T Steel Pinion - 48 D.P.
U2313	24T Steel Pinion - 48 D.P.
U2314	25T Steel Pinion - 48 D.P.
U2315	26T Steel Pinion - 48 D.P.
U2316	27T Steel Pinion - 48 D.P.
U2317	28T Steel Pinion - 48 D.P.
U2318	29T Steel Pinion - 48 D.P.
U3414	Pinion; Hard Alloy 48dp - 14T
U3415	Pinion; Hard Alloy 48dp - 15T
U3416	Pinion; Hard Alloy 48dp - 16T
U3417	Pinion; Hard Alloy 48dp - 17T
U3418	Pinion; Hard Alloy 48dp - 18T
U3419	Pinion; Hard Alloy 48dp - 19T
U3420	Pinion; Hard Alloy 48dp - 20T
U3421	Pinion; Hard Alloy 48dp - 21T
U3422	Pinion; Hard Alloy 48dp - 22T
U3423	Pinion; Hard Alloy 48dp - 23T
U3424	Pinion; Hard Alloy 48dp - 24T
U3425	Pinion; Hard Alloy 48dp - 25T
U3426	Pinion; Hard Alloy 48dp - 26T
U3427	Pinion; Hard Alloy 48dp - 27T
U3428	Pinion; Hard Alloy 48dp - 28T
U3429	Pinion; Hard Alloy 48dp - 29T
U3430	Pinion; Hard Alloy 48dp - 30T
U3431	Pinion; Hard Alloy 48dp - 31T
U3432	Pinion; Hard Alloy 48dp - 32T

**TEAM MERCHANDISE**

ED199206	EDS Pit Towel 110 x 70cm
G310	Schumacher Rubber Pit Mat - 750mm x 500mm
G315	Schumacher Pit Towel
G338	2 Tone Beanie Knitted Hat
G339L	Jacket - 3 Layer Softshell; Black - L 44inch
G339M	Jacket - 3 Layer Softshell; Black - M 41inch
G339S	Jacket - 3 Layer Softshell; Black - S - 38inch
G339XL	Jacket - 3 Layer Softshell; Black - XL 46inch
G339XS	Jacket - 3 Layer Softshell; Black - XS - 34inch
G339XXL	Jacket - 3 Layer Softshell; Black - XXL 48inch
G339XXXL	Jacket - 3 Layer Softshell; Black - XXXL 50inch
G340	Schumacher Baseball Cap - Black
G341	Schumacher Flat bill Cap - Black
G342L	T - Navy - Large 100% cotton knit mens
G342M	T - Navy - Medium 100% cotton knit mens
G342S	T - Navy - Small 100% cotton knit mens
G342XL	T - Navy - X-Large 100% cotton knit mens
G342XXL	T - Navy - XX-Large 100% cotton knit mens
G342XXXL	T - Navy - XXX-Large 100% cotton knit mens
G342XXXXL	T - Navy - XXXX-Large 100% cotton knit mens
G342XXXXXL	T - Navy - XXXXX-Large 100% cotton knit mens
G343L	Sweat-Navy-Large 80% cotton,20% polyester knit
G343M	Sweat-Navy-Med, 80% cotton,20% polyester knit men
G343S	Sweat-Navy-Small,80% cotton,20% polyester knit men

**TEAM MERCHANDISE Cont...**

G343XL	Sweat-Navy-XL, 80% cotton,20% polyester knit men
G344L	Polo - Navy - Large, 100% cotton knit mens men
G344M	Polo - Navy - Med, 100% cotton knit mens
G344S	Polo - Navy - Small, 100% cotton knit mens
G344XL	Polo - Navy - X-Large, 100% cotton knit mens
G344XXL	Polo - Navy - XX-Large, 100% cotton knit mens
G344XXXL	Polo - Navy - XXX-Large, 100% cotton knit mens
G344XXXXL	Polo - Navy - XXXX-Large, 100% cotton knit mens
G344XXXXXL	Polo - Navy - XXXXX-Large, 100% cotton knit mens
G351	Schumacher Thermo Mug
G352	Schumacher Umbrella
NR96398	Nosram Pit Towel 2

**TOOLS**

CR100	Shock Shaft Pliers - Purple
CR101	Shock Shaft Pliers - Black
CR102	Magnetic Parts Tray - Purple
CR103	Magnetic Parts Tray - Black
CR148	CORE RC - Polybutler Pit Box; Black
CR233	Piston Drilling Kit-1.1, 1.2, 1.3, 1.4, 1.5mm
ED181002	Chassis Droop Gauge Blocks 20mm for 1/8, 1/10 (2)
ED190012	Reamer with Protection Cap for Body - 14mm
H1031	Bearing Blaster Aerosol 500ml
H1032	Alloy Camber Gauge - 1/10th
H1055	GT85 Lube and Clean Aerosol 400ml
H1056	Loctite 243 Thread Lock
H1057	Loctite Precision Super Glue - 5g
HW010	Circlip Pliers; Internal - Wiha
MR-SUPER GLUE	Perfect Super Glue for Rubber Tyres
U2789	Schumacher Hex Driver - 1.5mm
U2790	Schumacher Hex Driver - 2.0mm
U2791	Schumacher Hex Driver - 2.5mm
U2795	Schumacher M3 Nut Driver
U2796	Schumacher M4 Nut Driver
U2818	Schumacher Body Reamer
U4229	Steel Spanner - 5.5mm/3.9mm

**BATTERIES**

CR059	CORE RC - Safe Charge Pouch 23x30cm
CR170	CORE RC Lipo Locker - 17 x 8 x 7cm
CR171	CORE RC - 4000mAhr 7.4V 20C/40C Saddle Lipo
G718	GP Alkaline AA Pencil; Card 4
G721	AA Pencil 2500NiMh - Card 4
GM99009	Lipo-saddle V-Maxx 60C 2x1S3P/5600 3, 7V G4
GM99018	Lipo Battery V-Maxx 70C 2S2P/6800 7.4v G
GM99024	Lipo Battery V-Maxx 70C 2S2P/7200 7.4V
H1046	T Connector; Red 2 Way - Male and Female
H1047	T Connector; Black 2 Way - Male and Female
H1048	T Connector; Red Sockets - pk4
H1049	T Connector; Black Sockets - pk4
MR-SB	MR33 Lipo Bag
NR99941	NOSRAM Lipo 5600 X-Treme Race Saddle 55C/110C-7.4V
NR99948	NOSRAM LiPo 5000 Saddle - 7.4V 50C
NR999500	Lipo 7200 Big Mama Hard Case 100C/50C-7.4V
NR999501	Lipo 7000 X-treme Race H/Case 55C-7.4V
NR999503	Lipo 5800 X-treme Race Saddle pk H/Case 55C-7.4V
NR999504	Lipo 4500 X-treme Race Short H/Case 110C/55C-7.4V
NR999505	Lipo 5200 X-treme Race H/Case 80C/40C - 7.4V
NR999506	Lipo 5700 X-treme Race H/Case 80C/40C - 7.4V
NR99951	Lipo 6200 Big Mama X-treme Race H/case 65C-7.4V
TP3800-2SPR65S	Thunder Power Lipo 3800mAh 2S shorty - 65C/130C
TP4P10E	Thunder Power 4 Pin Balance connector 10Extension"
TP4P8	TP 4 Pin Balance Connector 8 Colour Coded Wires"
TP5000-2SPR65S	Thunder Power Lipo 5000mAh 2S saddle - 65C/130C
TP5300-2SPR65B	Thunder Power Lipo 5300mAh 2S - 7.4V - 65C/130C
TP6000-2SPR65B	Thunder Power Lipo 6000mAh 2S - 7.4V - 65C/130C
TP6P10E	Thunder Power 6 Pin Balance Connector 10Extension"
TP6P13	TP 6 Pin Balance Connector 13 Colour Coded Wires"
TP6P4PE	Thunder Power 6 Pin Adaptor/Extension
TP-AL-2S	Adaptor Lead - 2S JST to TP
TPLSBL	Thunder Power Lipo Charge Bag Large 9 x 12"
TPLSBS	Thunder Power Lipo Charge Bag Small 7 x 8" x 5"

**BRUSHLESS ACCESSORIES**

CR133	Core Sensor Lead; 80mm
CR134	Core Sensor Lead; 180mm
GM2894.9	Sensor Adaptor Cable - Gm-Evo2/Novak-M
HW2361200	XERUN - Sensor Cable - 120mm
HW2362000	XERUN - Sensor Cable - 200mm
HW30502000014	XERUN-EZRUN-Multifunction LCD Program Box
HW30860200010	XERUN Competition Fan-2510SH-5v/0.16A for 2s
HW86020010	XERUN-EZRUN - Program Card for ESC
HW86030030	XERUN - Capacitors



**BRUSHLESS ACCESSORIES Cont...**

HW86080120 EZRUN - Heat Sink with Fan for 3660,3674 motors  
 HW86080130 EZRUN - Heat Sink with Fan for 4465 motors  
 HW86080150 XERUN Large Fan 3010HB-5V/0.18A for 2s  
 NR92500 USB Bridge - Speedo Firmware Update Device  
 NR92501 USB Bridge Spec2 - Speedo Firmware Update Device  
 NR92512 Cooling Fan; Low Profile - Include Mounting Screws  
 SP000007 Muti LED Program Card Version 2.0  
 SP000008 Reventon Blue-Tooth" Module"  
 SP000009 Reventon WiFi" Module"  
 SP000029 Sensor Unit +20 Timing"for V3.0 Motor-Green Color"  
 SP000034 Sensor Unit +10 Timing" for V3.0 Motor-Red Color"  
 SP000041 Sensor Unit for V3.0 - 4.0T/5.0T Motor  
 SP000059 Sensor Unit +40 Timing for V3.0 Motor Blue  
 SP138MS105 10.5R Stator for Competition Version 3.0 Motor  
 SP138MS135 13.5R Stator for Competition Version 3.0 Motor  
 SP138MS175 17.5R Stator for Competition Version 3.0 Motor  
 SP138MS215 21.5R Stator for Competition Version 3.0 Motor  
 SP162801 SP - Sensor Cable 180mm  
 SP162802 SP - Sensor Cable 90mm  
 SP162803 SP - Sensor Cable 250mm  
 SPSB428 Sensor unit with Team protect for V3.0 motor  
 TPM-P1000 Thunder Power Bearing Replacement Tool  
 TPM-P1001 T-Power Bearing Std 1/8x3/8x5/32 (2pcs) S/M 540"  
 TPM-P1002 T-Power Bearing Ceramic 1/8x3/8/5/32 (2pcs)S/M540"  
 TPM-P1005 Thunder Power Sensor Unit w/Std Bearing S/M540/550  
 TPM-P1007 Thunder Power Outer Can/Case w/Screws S/M 540  
 TPM-P1008 Thunder Power Timing Cap w/Screws S/M540/550  
 TPM-P1010 Thunder Power Sensor Wire Harness 110mm  
 TPM-P1011 Thunder Power Sensor Wire Harness 200mm  
 TPM-P1012 Thunder Power Sensor Wire Harness 270mm  
 TPM-P1014 Thunder Power Insulator Set (Fr/Rr) S/M 540/550  
 TPM-R540AHT Stock Spec 540 Hi-Torque Rotor 12.5/7.25/25.0 Grn  
 TPM-R540AMR Thunder Power Mod 540 Rotor 12.2/5.2/25.0 Purple  
 TPM-R540AMR-S Thunder Power Mod 540 Rotor 12.0/5.0/25.3 Gold  
 TPM-R540ASR T-Power Stock Spec 540 Rotor 12.2/7.25/24.2 Red  
 TPM-R540AST T-Power StockSpec Torque Rotor 12.2/7.25/25.0 Blue  
 TPM-S540A030 Thunder Power 3.0T Modified 540 Stator  
 TPM-S540A035 Thunder Power 3.5T Modified 540 Stator  
 TPM-S540A040 Thunder Power 4.0T Modified 540 Stator  
 TPM-S540A045 Thunder Power 4.5T Modified 540 Stator  
 TPM-S540A050 Thunder Power 5.0T Modified 540 Stator  
 TPM-S540A055 Thunder Power 5.5T Modified 540 Stator  
 TPM-S540A060 Thunder Power 6.0T Modified 540 Stator  
 TPM-S540A065 Thunder Power 6.5T Modified 540 Stator  
 TPM-S540A075 Thunder Power 7.5T Modified 540 Stator  
 TPM-S540A085 Thunder Power 8.5T Modified 540 Stator  
 TPM-S540A095 Thunder Power 9.5T Modified 540 Stator

**BRUSHLESS MOTORS**

GM97296 GM Pro 6.5T - Star Wind  
 NR90550 Cobra Brushless Motor - 6.5T  
 NR90562 Cobra 2 Brushless Motor - 8.5T  
 NR90648 Nosram Pure 2 BL - 10.5T  
 NR90649 Nosram Pure 2 BL - 9.5T  
 NR90664 Nosram Pure 2 BL - 7.5T  
 NR90673 PURE Evolution BL - 6.5t OCTA WIND  
 NR90684 Nosram Pure 2 BL - 5.5T  
 NR90689 Nosram Pure 2 BL - 5.0T  
 NR90704 Nosram Pure 2 BL - 4.0T  
 SP000148 1/10 Competition MMM Series 5.0R BL Motor  
 SP000149 1/10 Competition MMM Series 5.5R BL Motor  
 SP000151 1/10 Competiton MMM Series 4.0R BL Motor  
 SP13855V3 Speed Passion V3.0 Comp BL Motor; 5.5T  
 SP13865V3 Speed Passion V3.0 Comp BL Motor; 6.5T  
 SP13875V3 Speed Passion V3.0 Comp BL Motor; 7.5T  
 SP13885V3 Speed Passion V3.0 Comp BL Motor; 8.5T  
 TPM-540A055 Thunder Power 5.5T Modified 540 BL Motor  
 TPM-540A060 Thunder Power 6.0T Modified 540 BL Motor  
 TPM-540A065 Thunder Power 6.5T Modified 540 BL Motor  
 TPM-540A075 Thunder Power 7.5T Modified 540 BL Motor  
 TPM-540A085 Thunder Power 8.5T Modified 540 BL Motor  
 TPM-540A095 Thunder Power 9.5T Modified 540 BL Motor

**BRUSHLESS COMBO'S**

SPPRO105MMM Reventon-Pro ESC Grey V3.0 MMM 10.5R Combo  
 SPPRO135MMM Reventon-Pro ESC Grey V3.0 MMM 13.5R Combo  
 SPPRO175MMM Reventon-Pro ESC Grey V3.0 MMM 17.5R Combo  
 SPPRO215MMM Reventon-Pro ESC Grey V3.0 MMM 21.5R Combo  
 SPPRO65V3 Reventon-Pro ESC Grey-V3.0-6.5R Combo  
 SPPRO75V3 Reventon-Pro ESC Grey-V3.0-7.5R Combo  
 SPPRO85V3 Reventon-Pro ESC Grey-V3.0-8.5R Combo

**BRUSHLESS SPEEDCONTROLS**

CR173 PACE 45R Brushless ESC 1s/2s  
 CR174 PACE 45R Programming Card  
 GM97168.B GM-Genius 120 with Boost 3.7 - 7.4V  
 HW81010130 EZRUN-35A-SL - BL ESC - for 1/10 Car & Truck  
 HW81010190 EZRUN-60A-SL - BL ESC - for 1/10 Car & Truck  
 HW81010380 EZRUN-WP-60A-SL - BL ESC - for 1/10 waterproof  
 HW81010390 EZRUN-WP-80A-SL - BL ESC - for 1/10 waterproof  
 HW81010400 EZRUN-WP-SC8 -120A BL ESC - 1/10 1/8 waterproof  
 HW81020010 XTREME Stock BL ESC - Blue - 60A  
 HW81020011 XTREME Stock BL ESC - Black - 60A  
 HW81020170 XERUN - V2.1 - BL ESC-120A - Blue  
 HW81020340 XERUN - V3.1 BL-ESC - Blue 120A  
 HW81020350 XERUN - V3.1 BL-ESC - Black 120A  
 HW81020360 XERUN - V3.1 BL-ESC - Red 120A  
 HW81020380 XERUN - V2.1 - BL-ESC-90A-Blue  
 NR90430 NOSRAM One Brushless ESC  
 NR90960 Comet EVO Brushless Speed Control  
 NR90970 Comet HD Brushless Speed Control  
 NR90999 Pearl Upgrade Kit -Mod + Stock  
 SP000043 Reventon-R ESC - 2S - Orange  
 SP000063 Reventon-R ESC - 2S - Blue  
 SP000064 Reventon-R ESC - 2S - Silver  
 SP000162 Reventon Pro - ESC-2S-Blue  
 SP000222 Reventon Pro ESC-2S-Black/Grey  
 SP000739 Reventon Pro ESC-2S - V1.1 Black  
 SPEXT98802LPB Speed Passion LPF V2.0 ESC - Blue  
 SPEXT98802LPF Speed Passion LPF V2.0 ESC - Carbon Look  
 SPEXT98802LPS Speed Passion LPF V2.0 ESC - Silver  
 SPEXT98802PRO Speed Passion GT V2.0 ESC - Carbon Look  
 SPEXT98802S Speed Passion GT V2.0 ESC - Silver

**CHARGERS AND DISCHARGERS**

CR114 UDC Balance Adaptor Set JST-XH to JST-EH 2-6S  
 CR161 UAC50 Charger 12v/110-240v 6A  
 CR176 T Connector Female to EC3 Male Lead  
 G834 Charger 240v UK; 7.2/Tx/Croc 1.2-12v  
 GM6468.GB Ultramat 16S + 3076  
 NR91400 Sigma Power Charger  
 NR91555 Stealth Touch Evolution Charger  
 NR93160 Nosram Power Supply 13.8V / 20A  
 NR95815 Nosram Universal Charging Lead-Tamiya/JST Plug  
 NR95816 Nosram Universal Chg Lead-2S Lipo H/Case/Bal Adpt  
 NR95817 Nosram Universal Chg Lead- US-Style Plug  
 TP1201P 100-240V AC - 12V DC, 1.0A Switching Adaptor TP103  
 TP1205P 100-240V AC-12V DC, 5.0A Switching Adaptor  
 TP14SAB-TPJXH Balance Conn Adaptor 2S-14S JST-XH - TP1430C  
 TP205V Thunder Power 2-5 Cell Lipo Smart Balancer  
 TP610C Thunder Power 10 Amp DC Balance Charger  
 TP610C-ACDC Thunder Power 10 Amp AC/DC Balance Charger  
 TP610C-BL2 Balance Conn Adaptor 2S/6S JST-XH 610C-ADC  
 TP820CD Dual Port 20A DC charger/Cycler  
 TP8SAB-TPJXH Balance Conn Adaptor Board 2S-8S JST-XH 820CD

**ELECTRONICS**

AN530400HV Digital BL Servo 10.7Kg for 1/10th Steering  
 AN530410HV Digital BL Servo 22Kg for 1/8 & 1/10 Buggy/Truggy  
 CR007 CORE RC Silicone Wire 12g - Red/Black 2x50cm  
 CR008 CORE RC RED Connector with 2x4mm Tubes  
 CR009 CORE RC RED Connector with 2x4mm Males  
 CR050 CORE RC Silicone Wire 12g - Red 1 Metre  
 CR051 CORE RC Silicone Wire 12g - Black 1 Metre  
 CR052 CORE RC Silicone Wire 12g - Blue 1 Metre  
 CR053 CORE RC Silicone Wire 12g - Red 50 Metre Reel  
 CR054 CORE RC Silicone Wire 12g - Black 50 Metre Reel  
 CR055 CORE RC Silicone Wire 12g - Blue 50 Metre Reel  
 CR115 CORE RC Silicone Wire 12g - Red/Black/Blue 3x50cm  
 CR119 Heatshrink 1.5mm dia Black - 20pcs  
 CR120 Heatshrink 2.0mm dia Black - 20pcs  
 CR124 Heatshrink 6.0mm dia Black - 20pcs  
 CR125 Heatshrink 6.0mm dia Red - 20pcs  
 CR151 CODE 2.4G FHSS LCD 2 Stick TxRx  
 CR152 CODE 2.4G FHSS LCD - Rx Only  
 CR153 CODE 2.4G FHSS Sport 2 Stick TxRx  
 CR154 CODE 2.4G FHSS Sport - Rx Only  
 CR155 Antenna 2.4G  
 CR162 CORE RC Sensor Checking Widget  
 CR195 Portable Emergency 60W Soldering Iron  
 ED199502 EDS Ultra Bright L.E.D. Light Stand  
 GM7952 Servo; Digital 806 MG-BB 0.08s 19.9Kg  
 GM7953 Servo; Digital 807 MG-BB 0.06s 15.3Kg  
 GM7954 Servo; Digital 808 MG-BB 0.04s 8.8Kg  
 GM94050 GM Servo SLP High Voltage Brushless  
 GM94051 GM Servo SST High Voltage Brushless  
 GM94411 GM Soldering Station 90W ESD



**3 Layer Soft Shell Team Jacket - Black**

- G339XS Extra Small - 34 inch chest
- G339S Small - 38 inch chest
- G339M Medium - 41 inch chest
- G339L Large - 44 inch chest
- G339XL X Large - 46 inch chest
- G339XXL XX Large - 48 inch chest
- G339XXXL XXX Large - 50 inch chest



**Team Hooded Sweatshirt - Navy Blue**

- G343S Small
- G343M Medium
- G343L Large
- G343XL Extra Large



**G352 Schumacher Team Umbrella**



**Caps - Black**

- G340 Schumacher Baseball Cap
- G341 Schumacher Flat bill Cap



**2013 Team Polo Shirt - Navy blue**

- G344S Small
- G344M Medium
- G344L Large
- G344XL X Large
- G344XXL XX Large
- G344XXXL XXX Large
- G344XXXXL XXXX Large
- G344XXXXXL XXXXX Large



**2013 Team T-Shirt - Navy blue**

- G342S Small
- G342M Medium
- G342L Large
- G342XL X Large
- G342XXL XX Large
- G342XXXL XXX Large
- G342XXXXL XXXX Large
- G342XXXXXL XXXXX Large



**G338 2 Tone Beanie Knitted Hat**



**G351 Schumacher Thermo Mug**



**G315 Schumacher Pit Towel**



**G310 Schumacher Rubber Pit Mat  
750mm x 500mm**



**S500B - Team Schumacher Banner 3ft x 6ft**

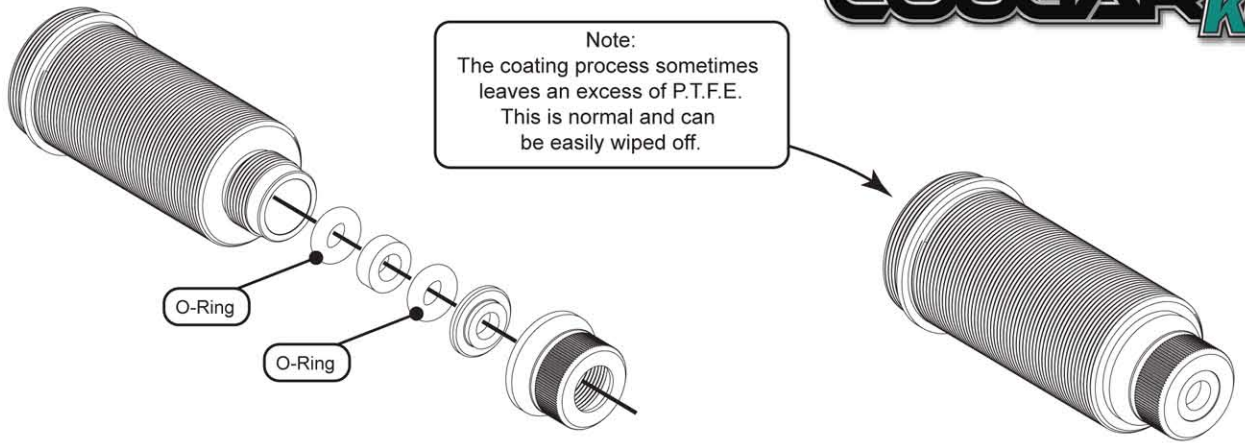

Step 38 A

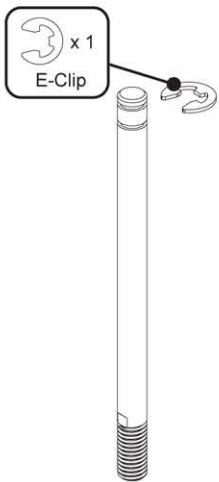

Step 38 B

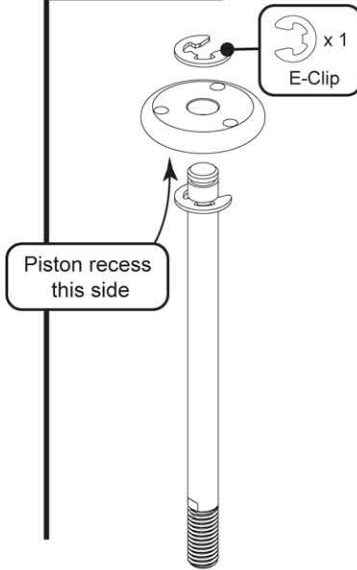

Step 38 C

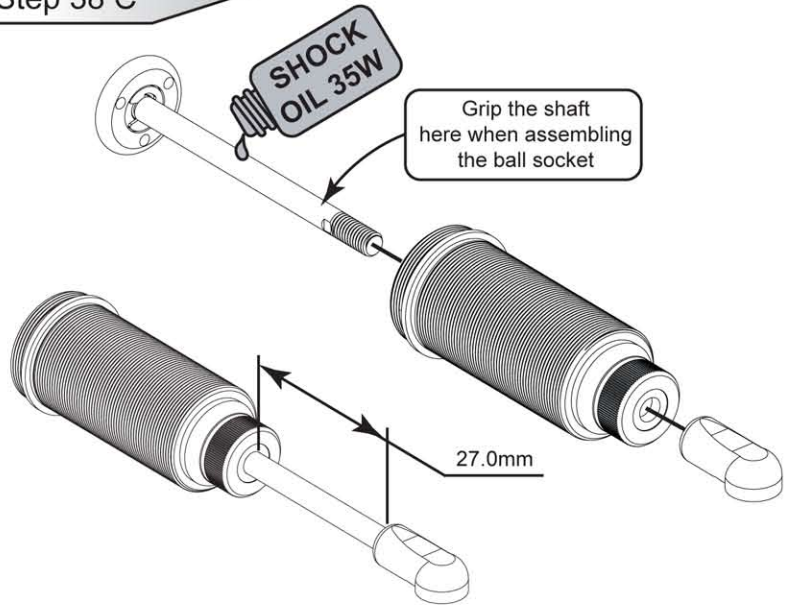

Step 39 A

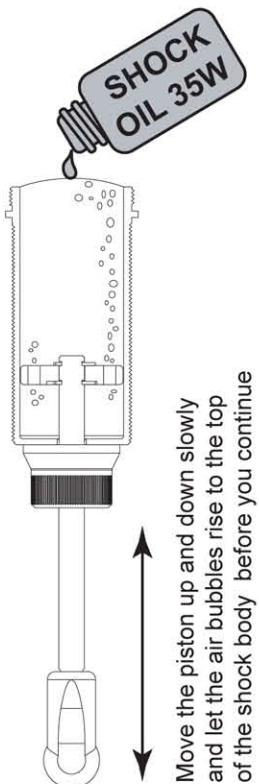

Step 39 B

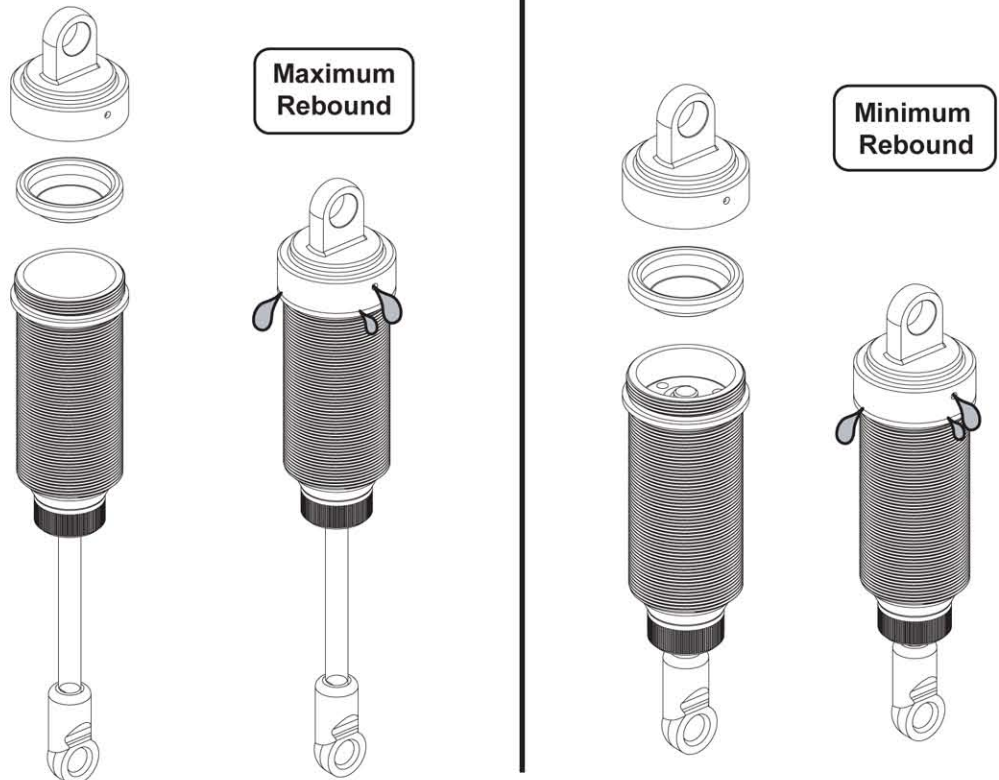

Step 39 C



Step 39 D

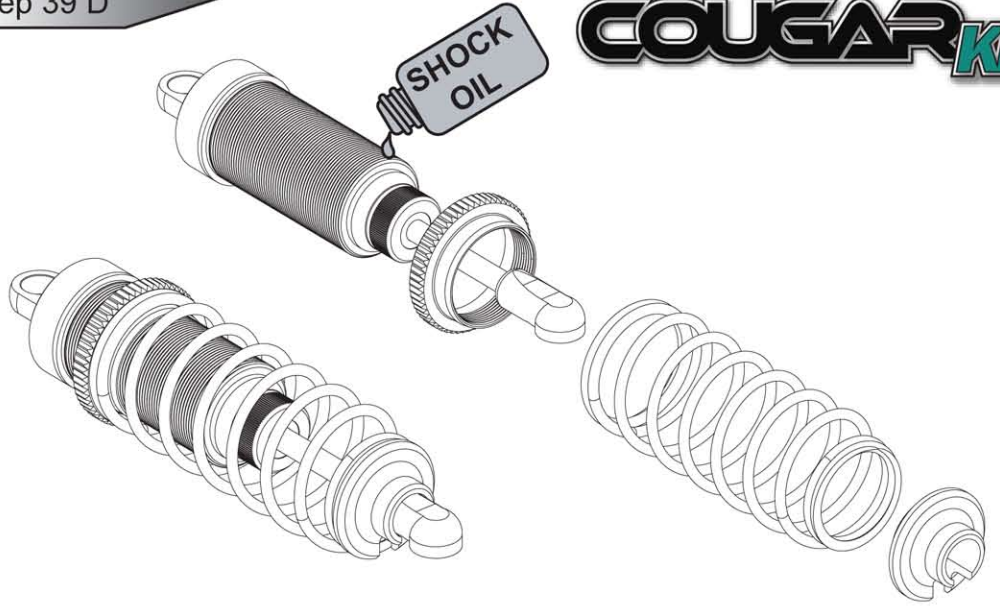

Step 40

Note:  
The coating process sometimes leaves an excess of P.T.F.E. This is normal and can be easily wiped off.

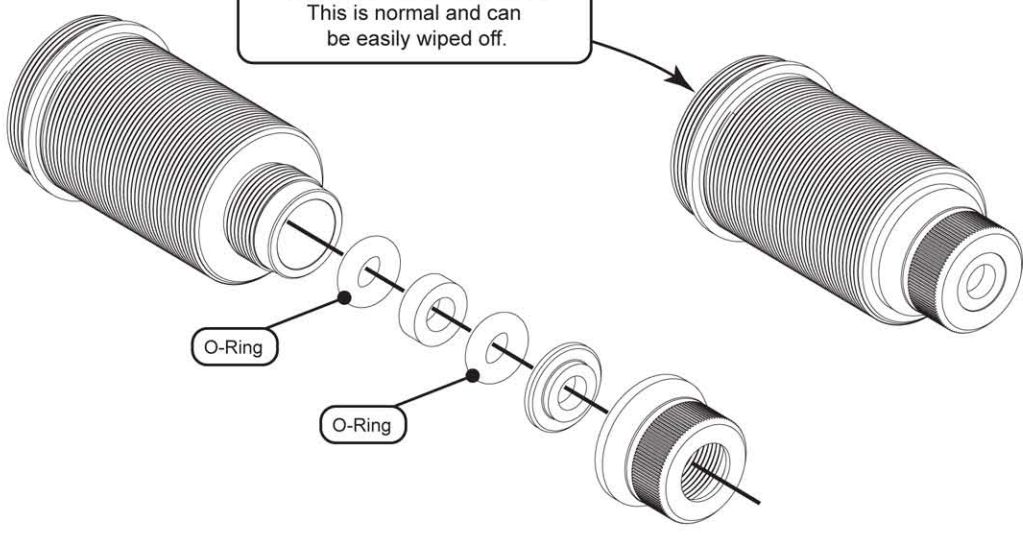

Step 41 A

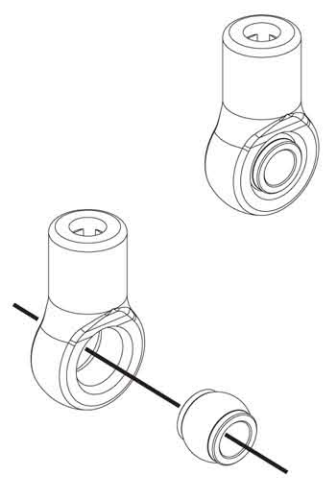

Step 41 B

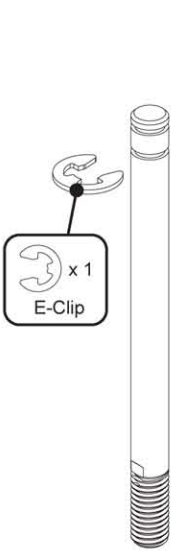

Step 41 C

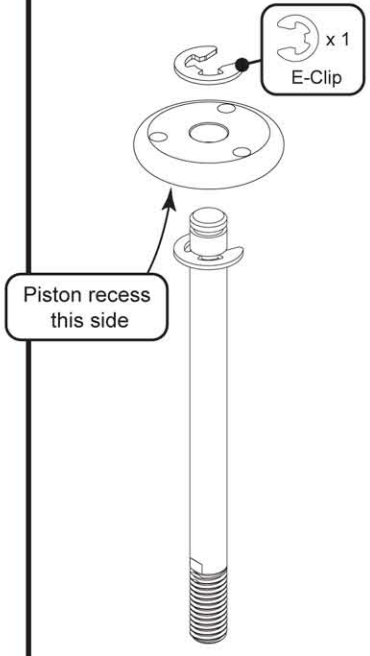

Step 41 D

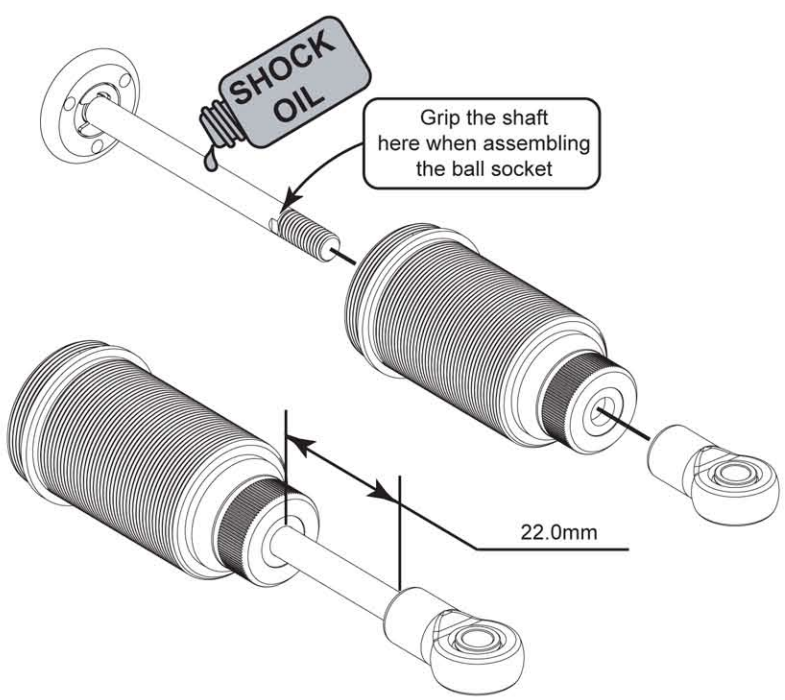

Step 42 A

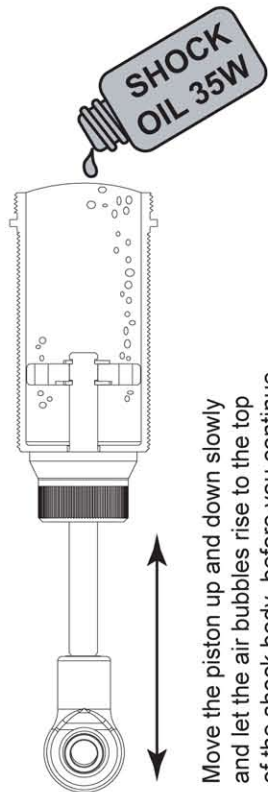

Move the piston up and down slowly and let the air bubbles rise to the top of the shock body before you continue

Step 42 B

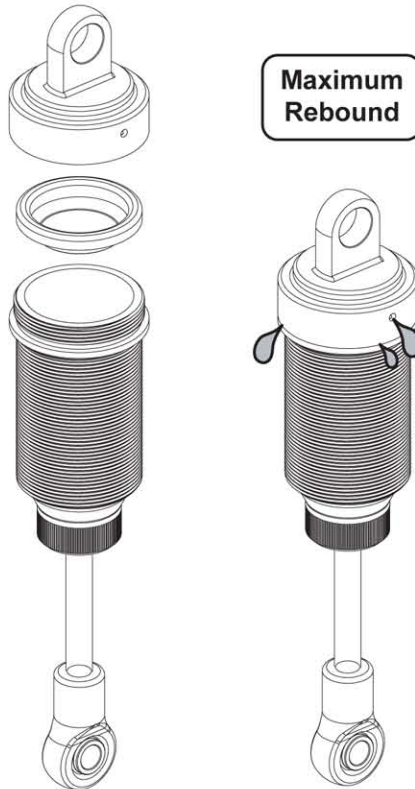

Maximum Rebound

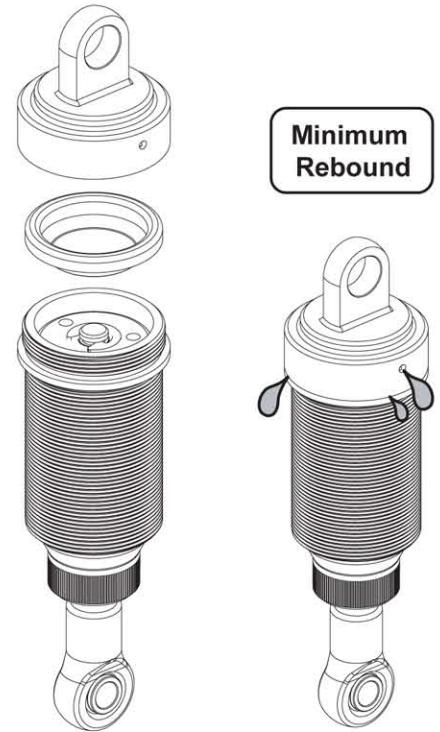

Minimum Rebound

Step 42 C



Step 42 D

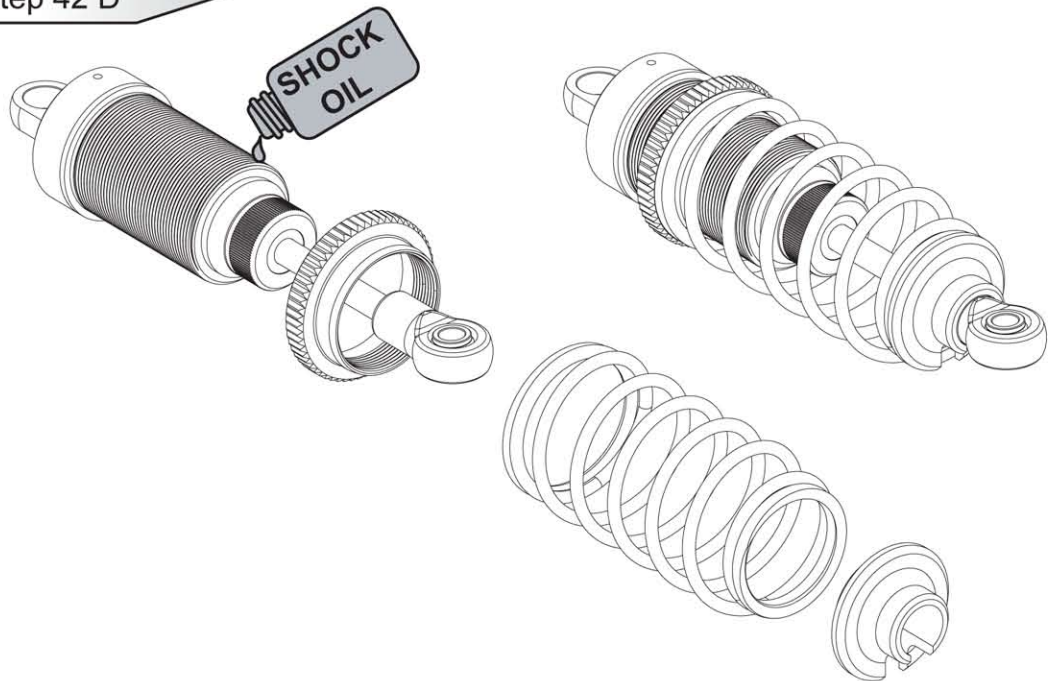

Silicone Oils



- CR200 CORE R/C Silicone Oil - 100 cSt - 60ml
- CR201 CORE R/C Silicone Oil - 150 cSt - 60ml
- CR202 CORE R/C Silicone Oil - 200 cSt - 60ml
- CR203 CORE R/C Silicone Oil - 250 cSt - 60ml
- CR204 CORE R/C Silicone Oil - 300 cSt - 60ml
- CR205 CORE R/C Silicone Oil - 350 cSt - 60ml
- CR206 CORE R/C Silicone Oil - 400 cSt - 60ml
- CR207 CORE R/C Silicone Oil - 450 cSt - 60ml
- CR208 CORE R/C Silicone Oil - 500 cSt - 60ml
- CR209 CORE R/C Silicone Oil - 550 cSt - 60ml
- CR210 CORE R/C Silicone Oil - 600 cSt - 60ml

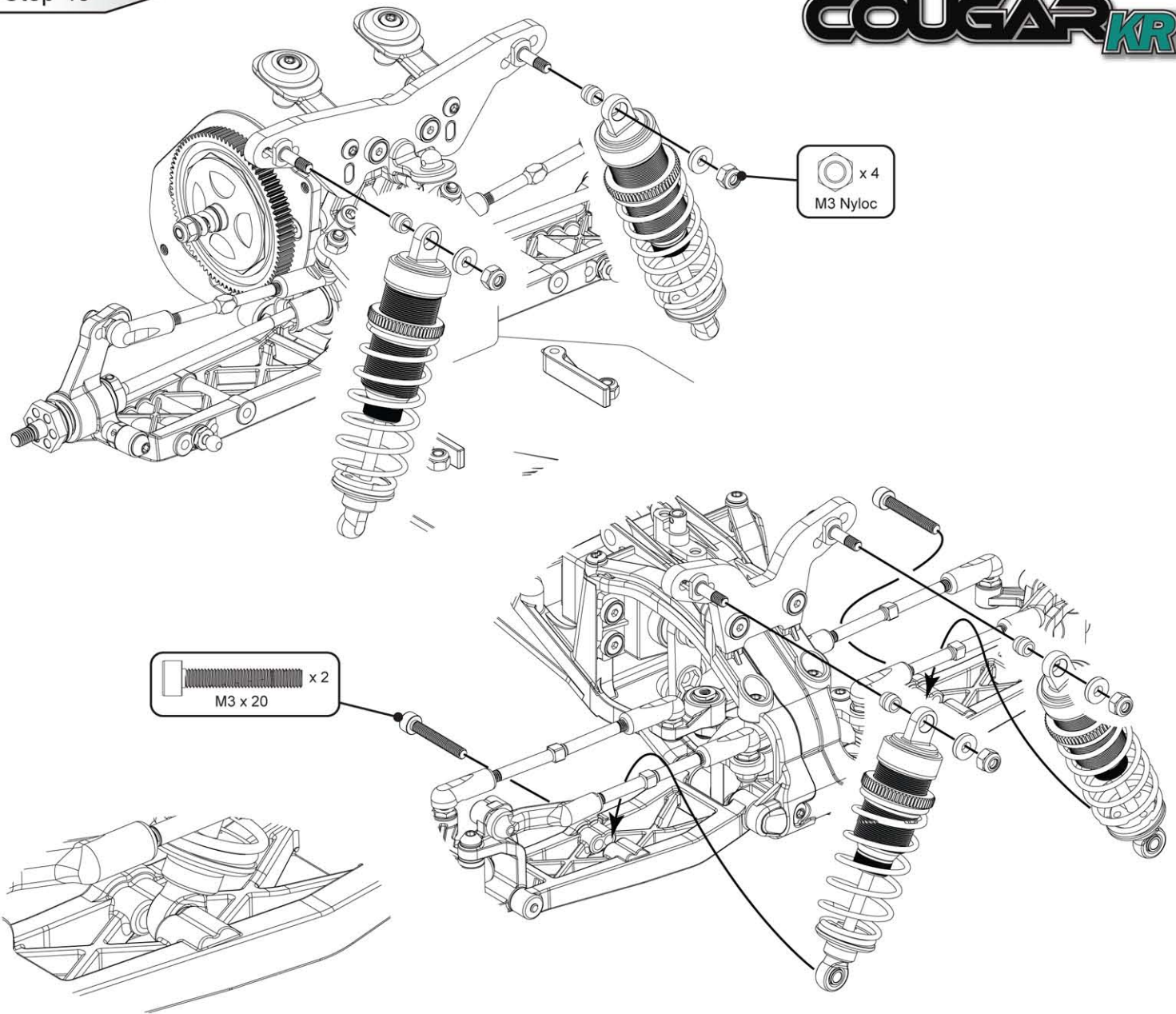

Step 44

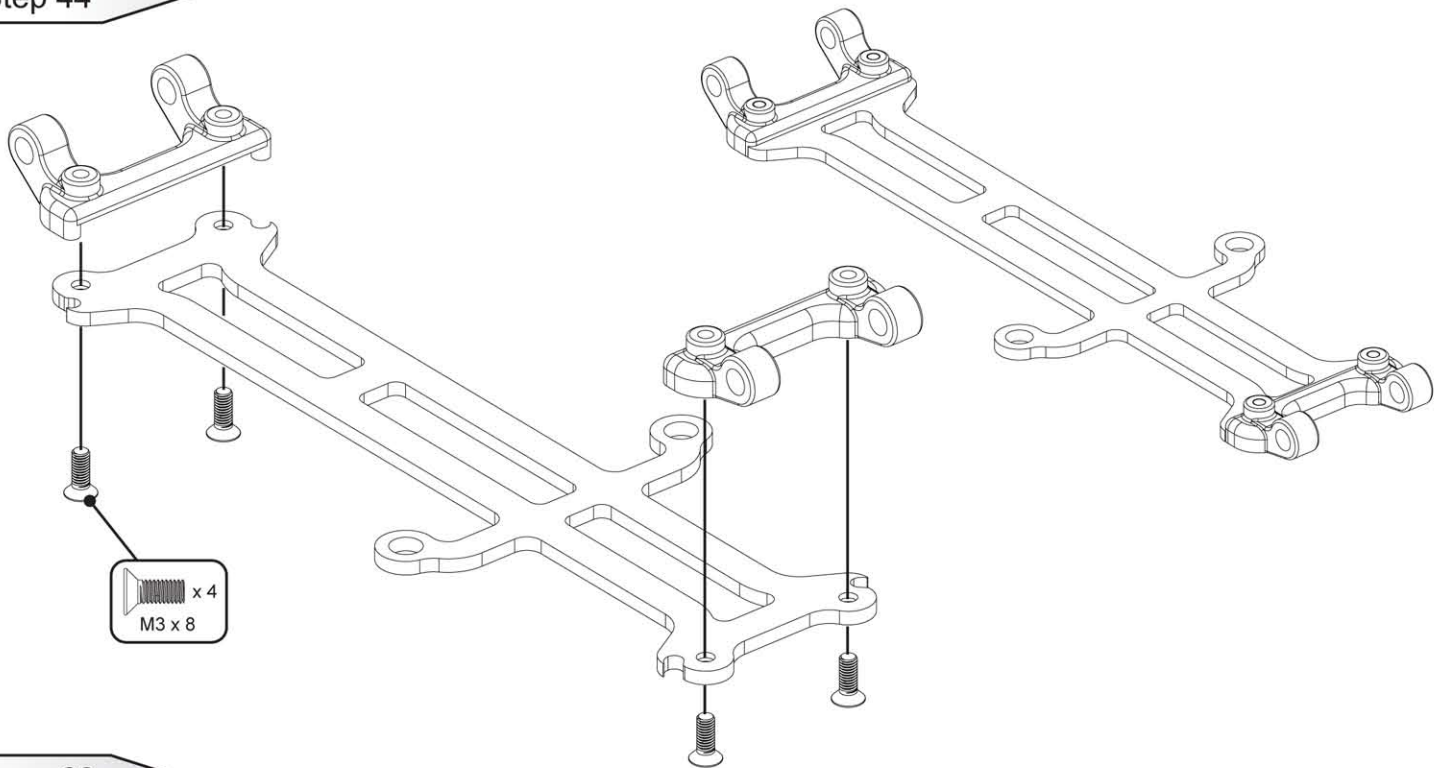

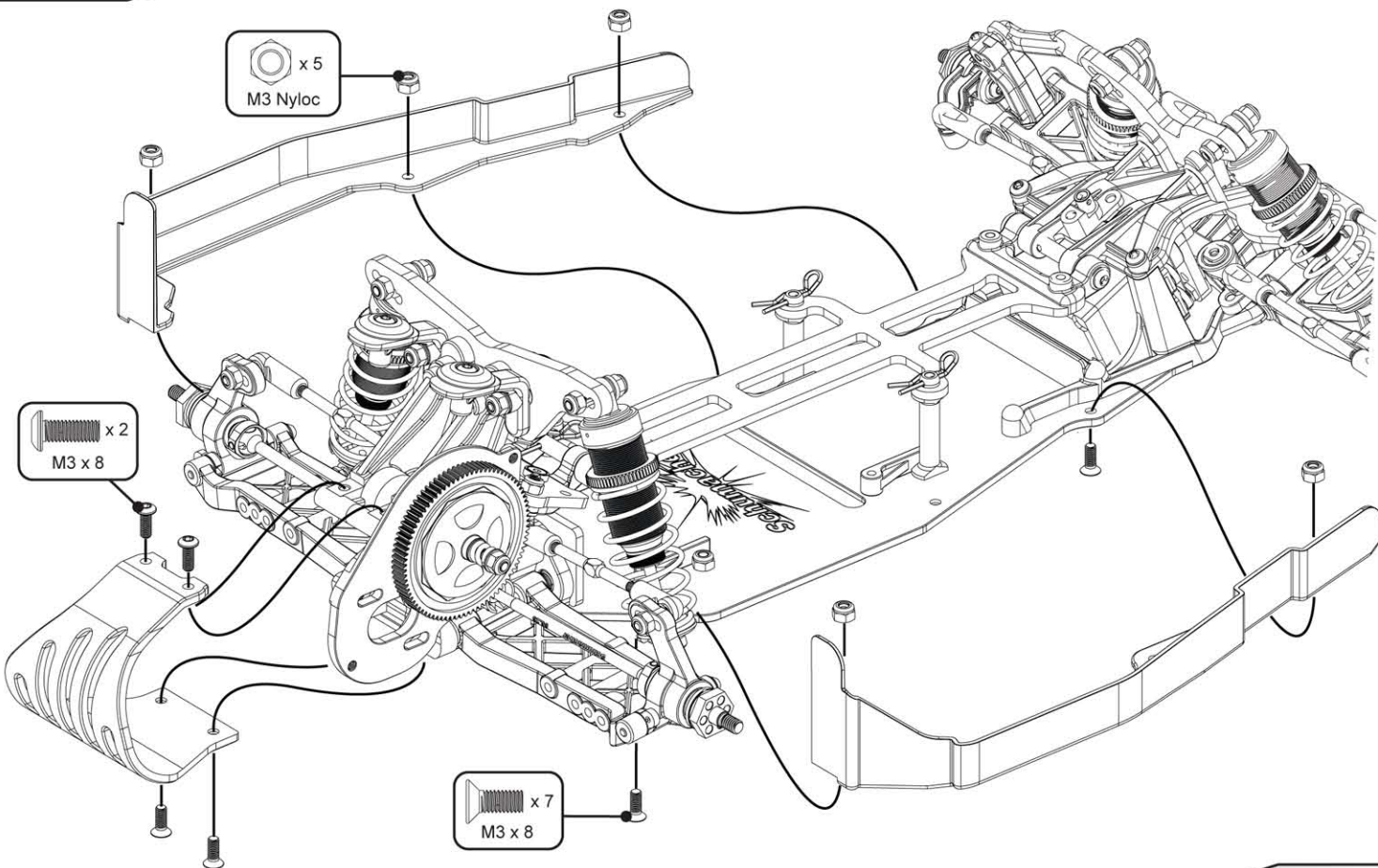
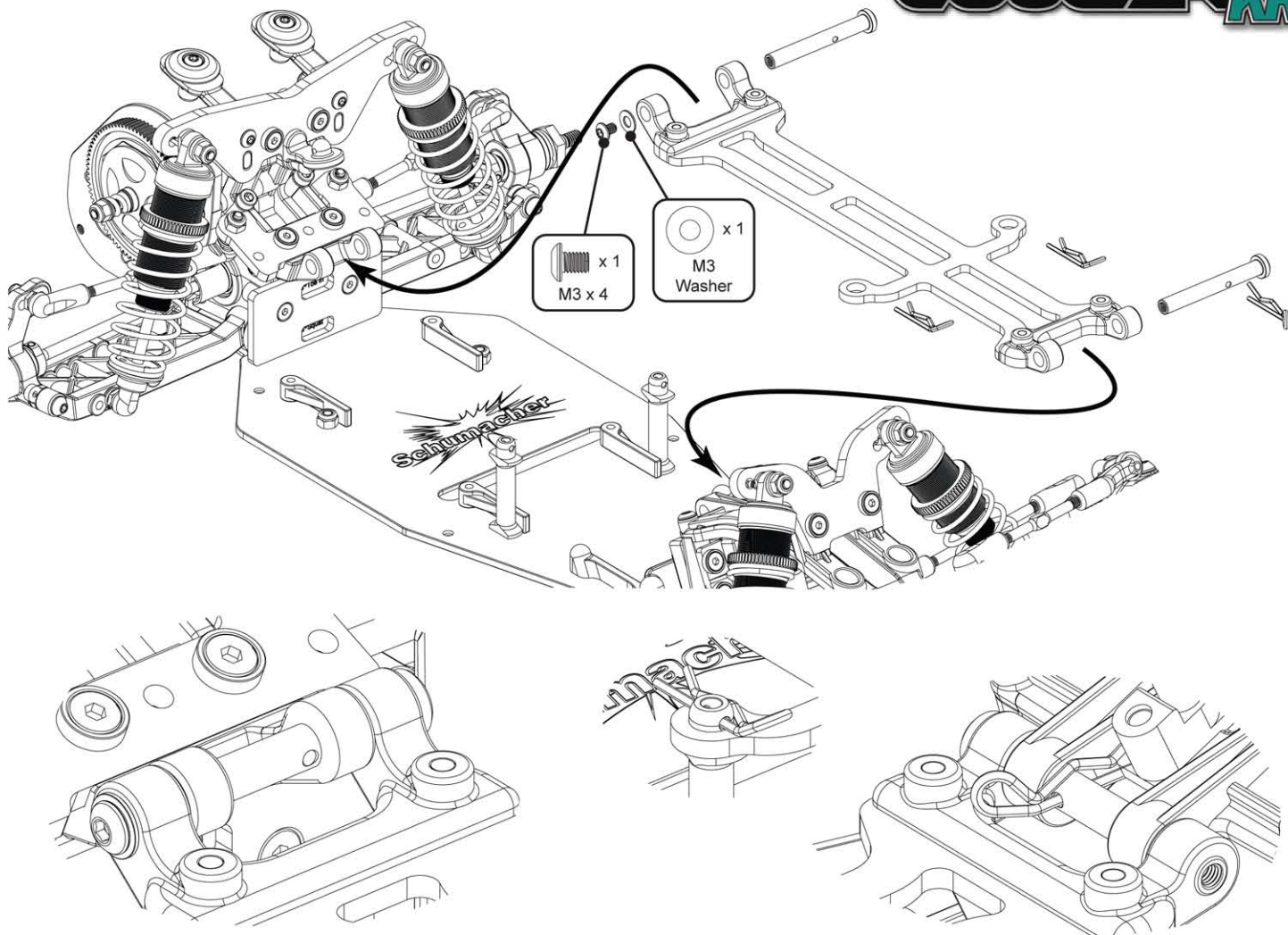

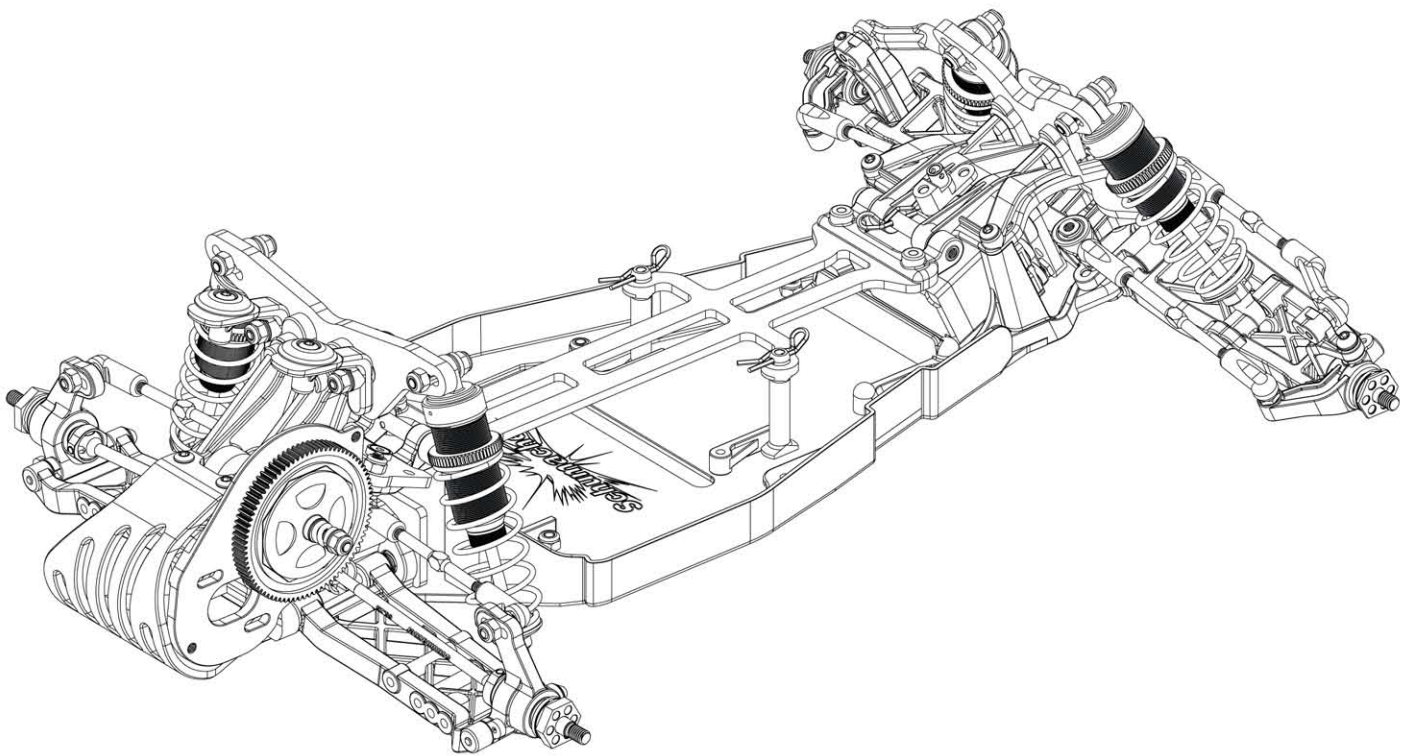

Step 47 A

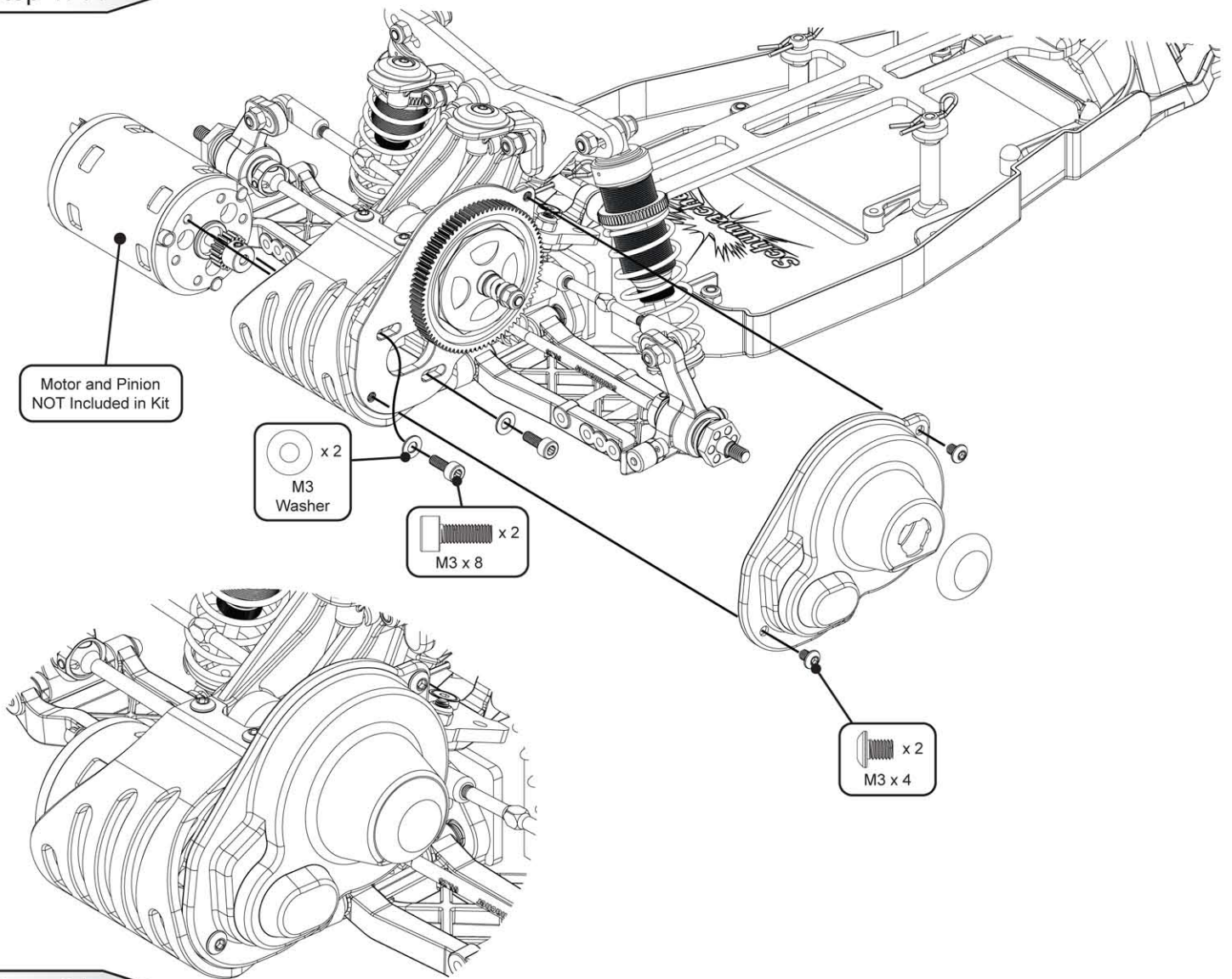



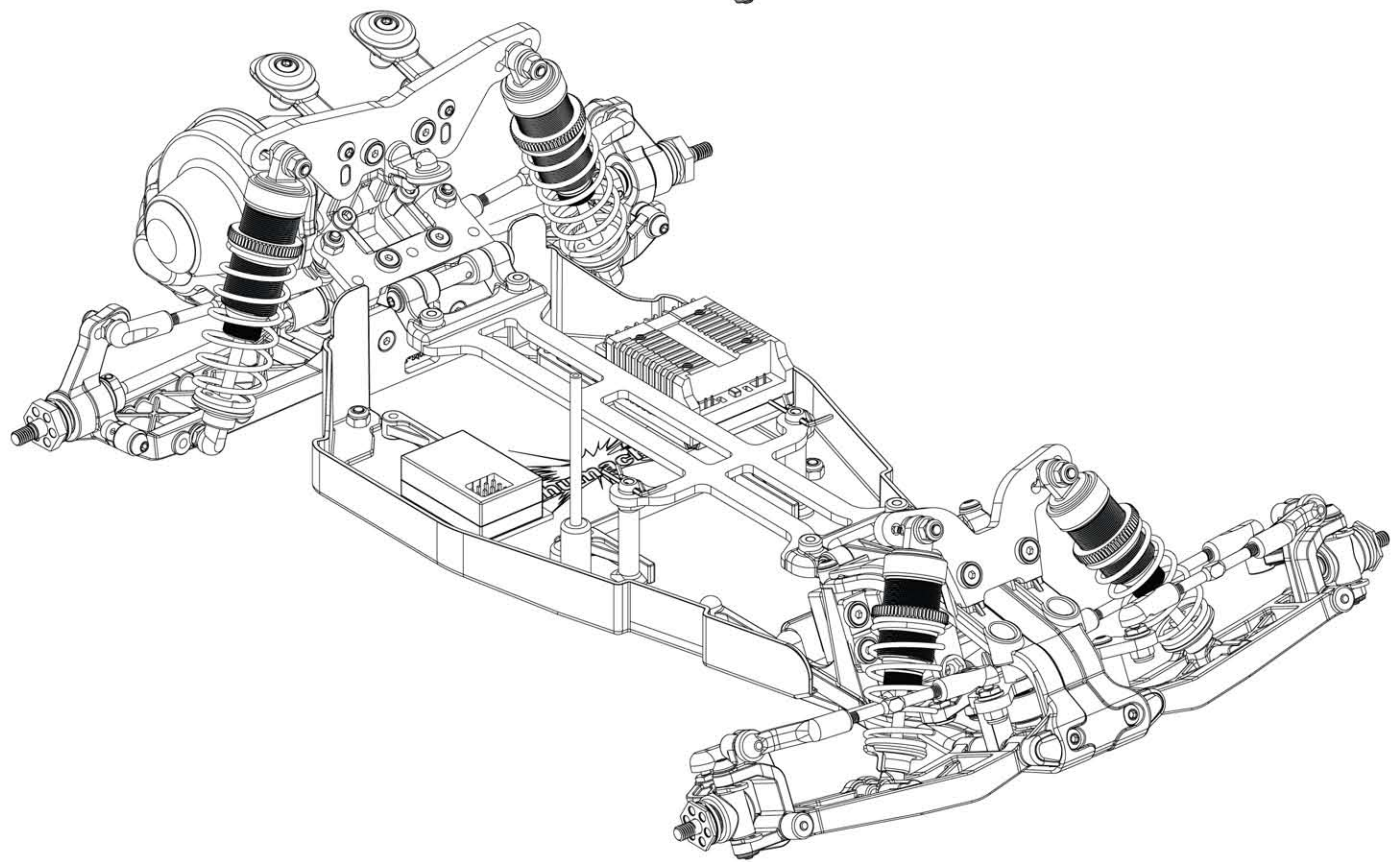
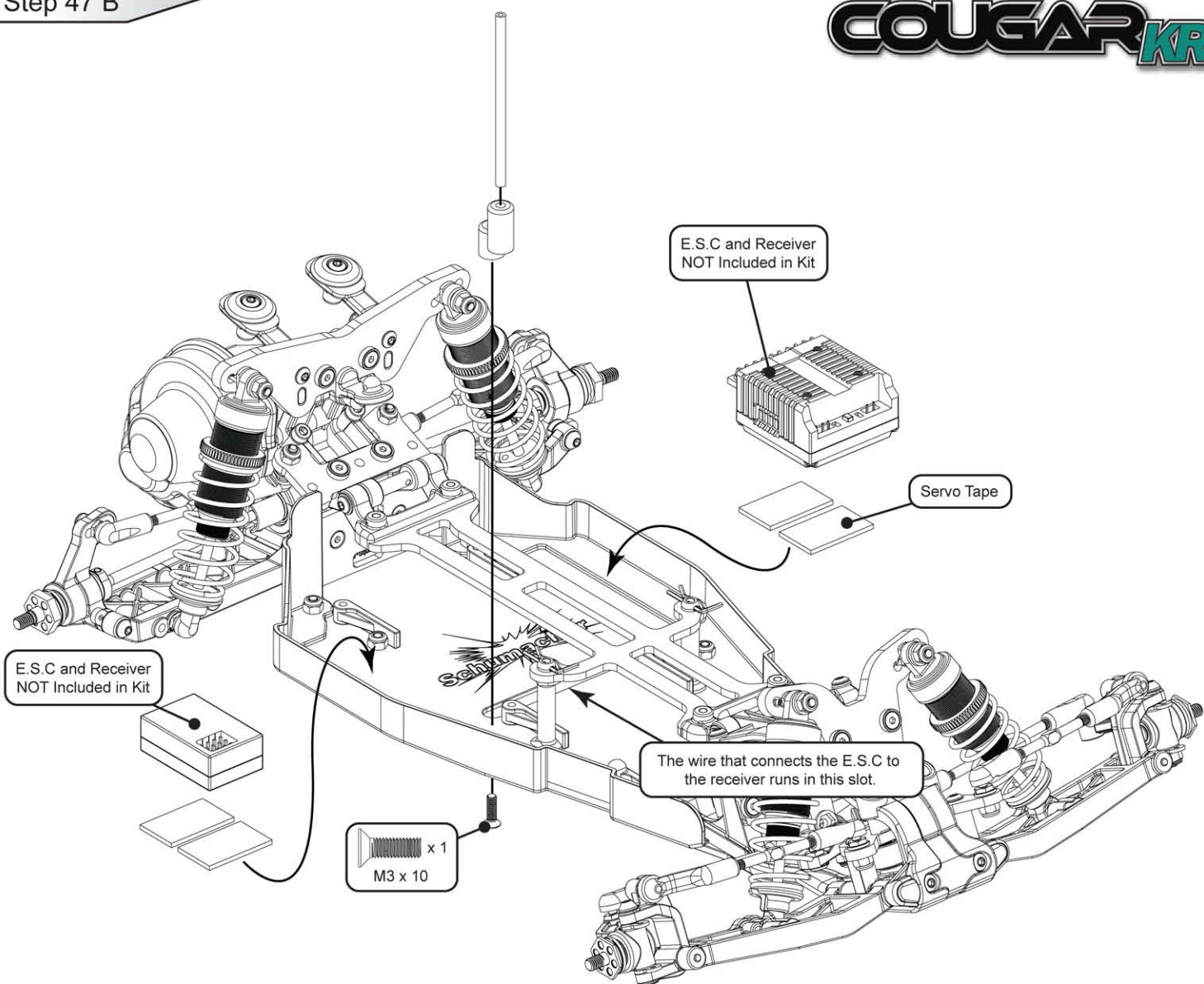

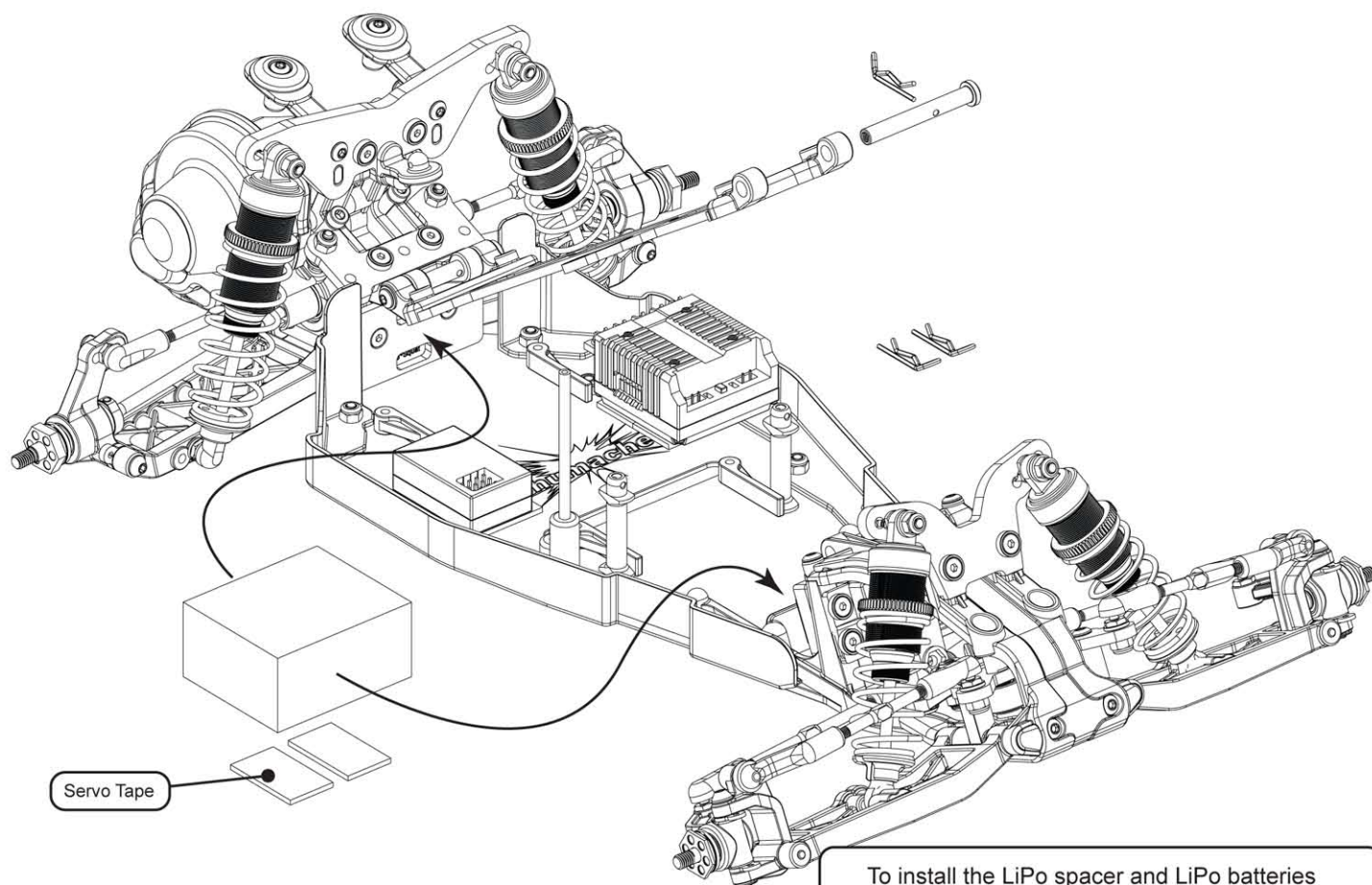

To install the LiPo spacer and LiPo batteries remove the R-clips from the top deck posts and the front top deck pin then remove the pin. Lift the Topdeck up and out of the way. Install the LiPo spacer and LiPo battery, then close the top deck down and replace the R-clips.

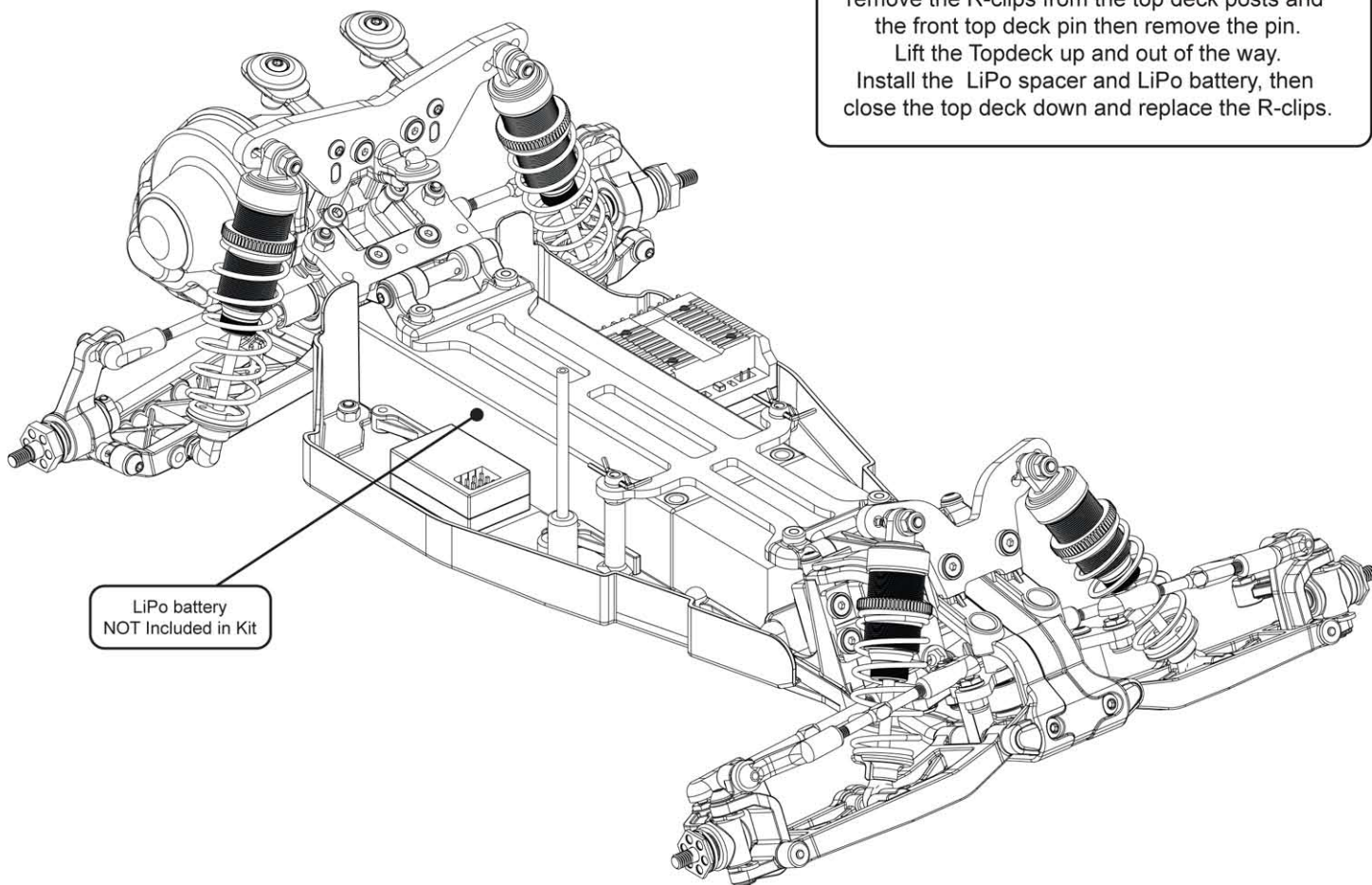

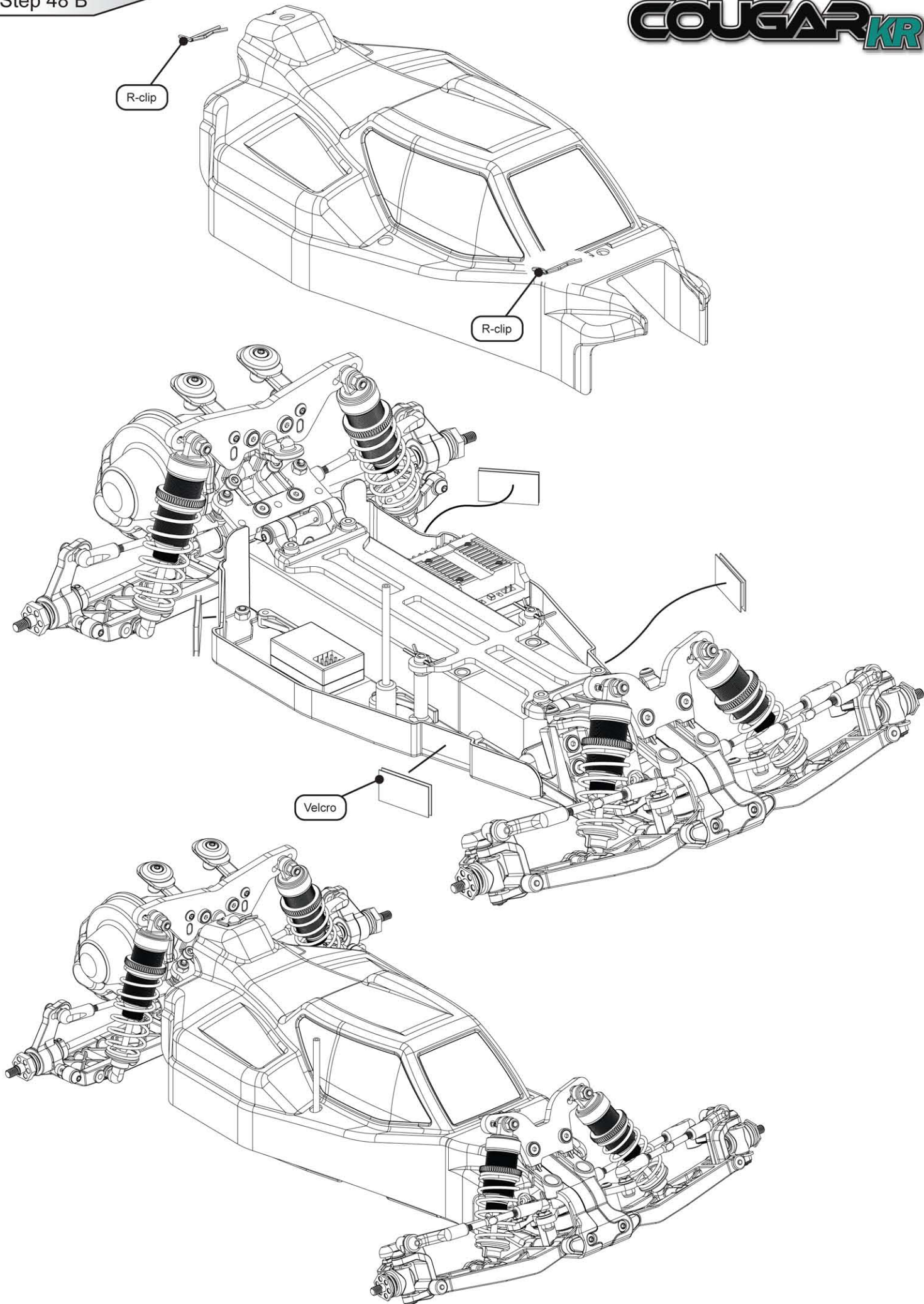

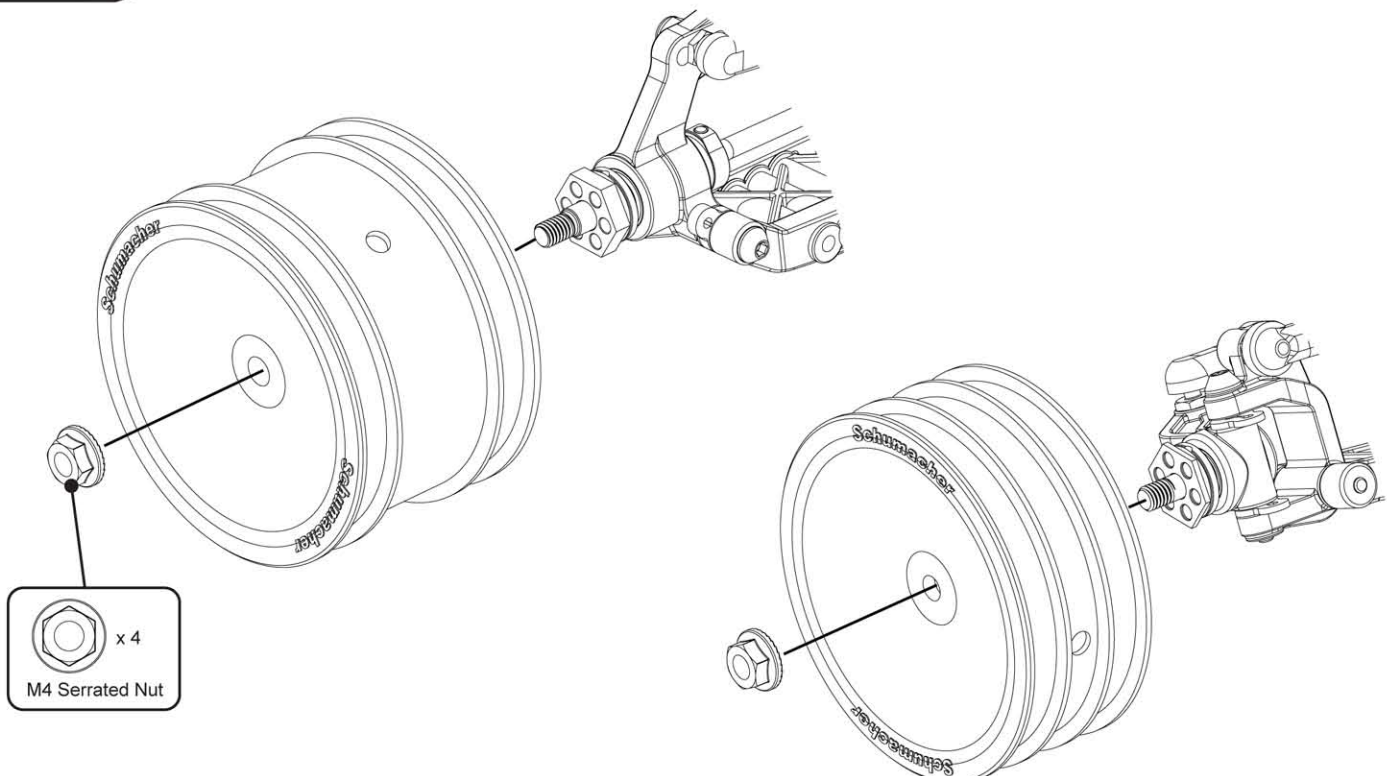
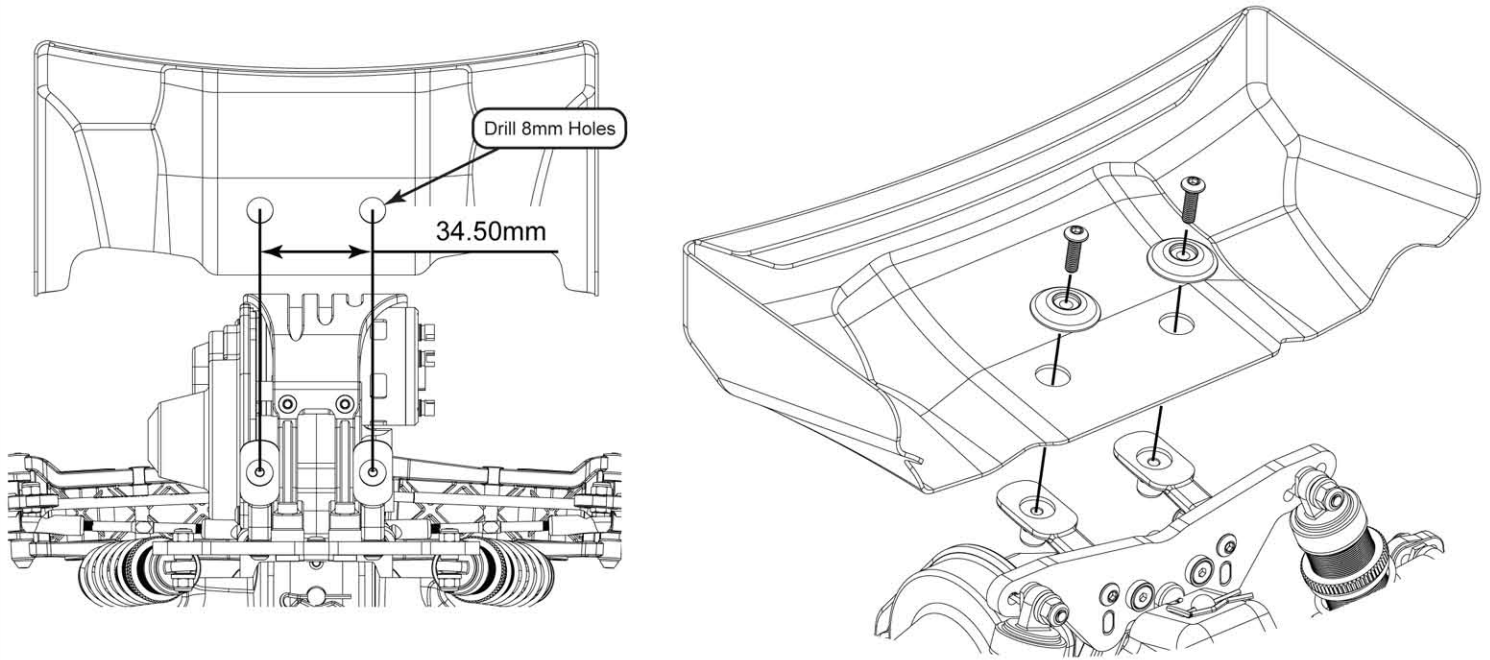
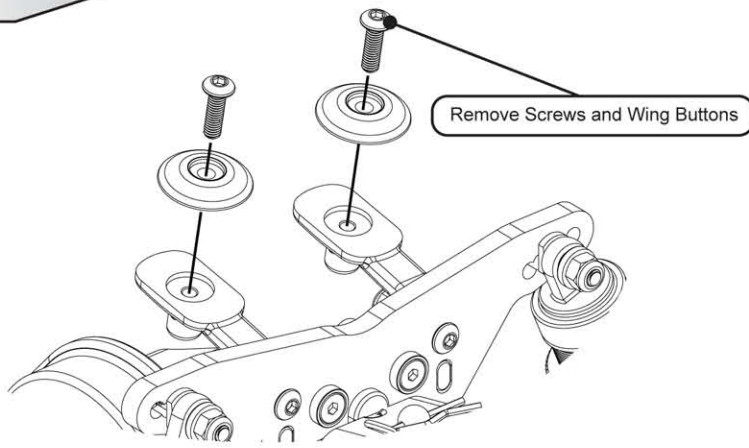

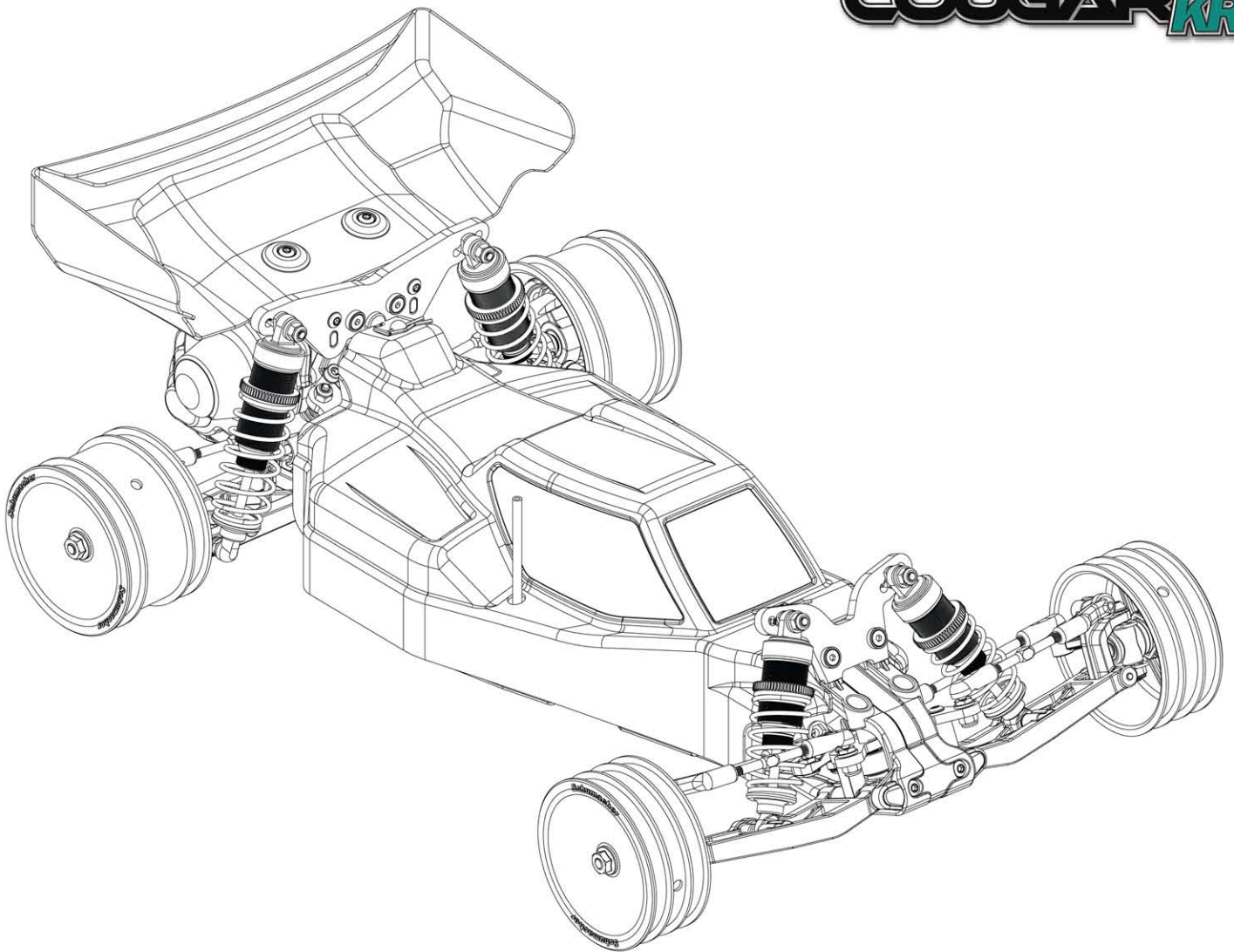

### Ball Differential

For consistent performance it is vital that the differential action should be smooth and free. Diff adjustment is not a tuning aid and the diff should never be allowed to slip. A loose diff can usually be recognised by a "chirping" sound when powering away from turns or landing under power from large jumps. When rebuilding your ball differential we recommend using a U1954 thrust race and U3019 Ceramic Nitride balls for ultimate reliability and weight saving.

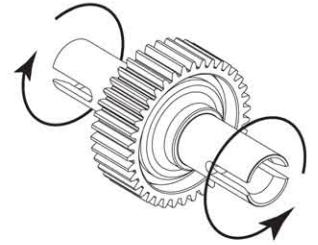

### Gear Differential

Geared Diffs can give different driving characteristics. The handling of the diff is tuned by changing the oil. A recommended starting point is 2000 cSt (CR216). Recommended option oils would be 3,000 cSt (CR217) and 1000 cSt (CR214). Changing to a thinner oil will give the car more straight line drive, thicker oil will give the car more stability.

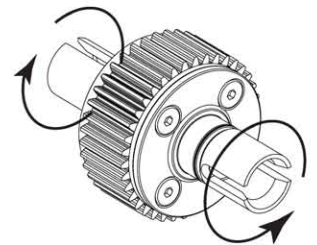

### Slipper Clutch

On most tracks it is best to start with the slipper on a tight setting, and gradually loosen the spring tension, until you achieve the most consistent drive away from turns without spinning the car or pulling wheelies. Make sure you still have enough drive when launching the car from the up ramps. **WARNING**, do not run the slipper too loose as it could melt the plastic spur gear.

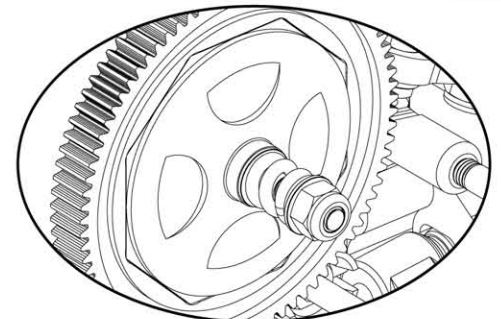

## Front Toe In

Front toe in should be set to 0° (both front wheels pointing straight ahead) this will be the best setting for most track conditions. Adding slight toe out will increase initial turn in. Whereas slight toe in will make this initial turn in a little softer.

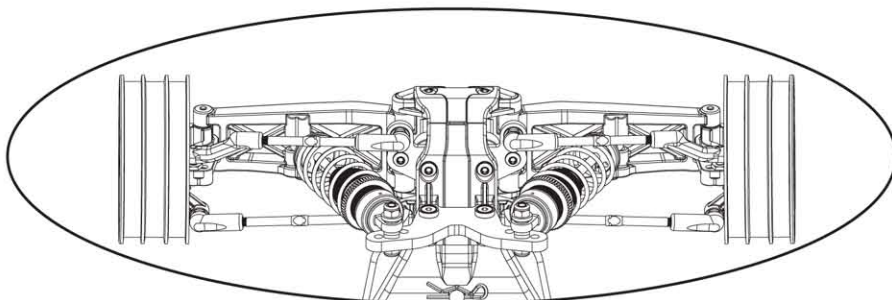

## Front Wishbone Shock Mounting Hole

The inboard hole on the wishbone is the standard setting for most tracks. Moving the shock out to the outer hole makes the car less reactive. It decreases the initial turn in and keeps the front of the car flatter through the turns. This setting also makes the front end stiffer and reduces the front suspension travel.

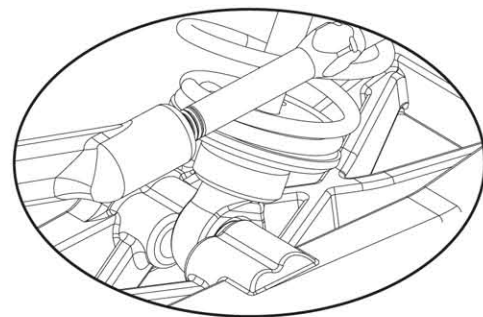

## Front Camber

The usual team setting for static front camber is 1-2° negative at ride height (the top of the wheel is leaning inwards towards the car). Increasing the static camber will generally increase the mid corner steering, whereas decreasing the static camber usually makes the car smoother to drive by reducing the steering response.

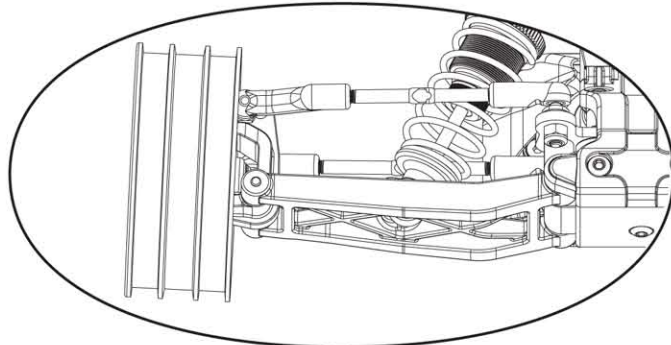

## Front Camber Links

The kit front camber link position and length are what the Team recommend for most tracks. Using a long front link makes the front of the car roll more and will give less steering reaction at high speed. It is also not quite as good on very bumpy tracks. We would probably recommend this on fairly smooth high grip tracks. A shorter front link will make the car roll less and quicken the initial steering response. This is a better choice for bumpy low grip tracks. Lowering the inside ball stud will give a similar result to shortening the link, and raising it will give a similar result to lengthening the camber link, but with less total effect.

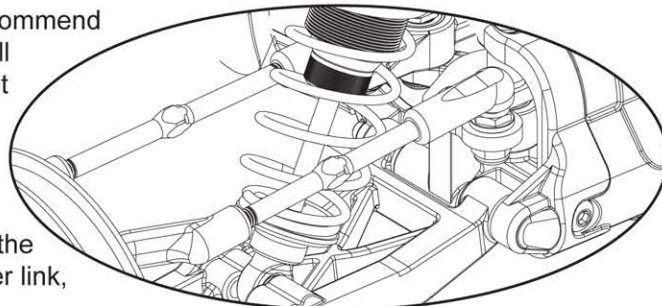

## Front Yoke

The rake angle (kick up) is 25° on the cougar and needs adding to the castor block angle to get the total castor angle. The standard car uses a 0° castor block making the standard car 25° in total; this can be increased to 30° by using the optional 5° castor block. Using more castor gives better corner entry steering but less power on steering at corner exit, and will make the steering feel a little softer than when using the standard 25° setup.

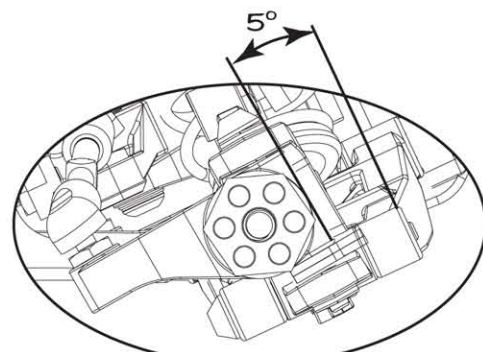
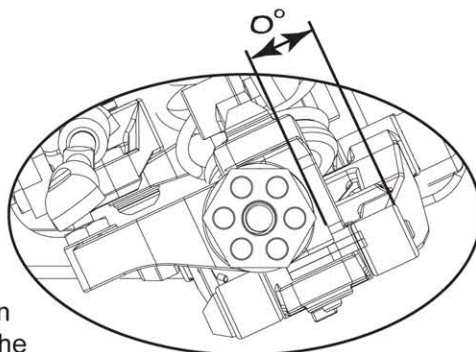

## Front Shock Mount

The middle hole on the front shock mount is the most widely used position. Moving the shock to the outer position will make the car react faster and increase the initial steering response, it may however stiffen the suspension which may require an oil and spring change so that the cars suspension feels the same. By moving the shock to the inner hole will soften the suspension and slow down the steering reaction and make the car smoother on bumpy tracks. Again you may need to alter the oil and spring combination to get the suspension correct again.

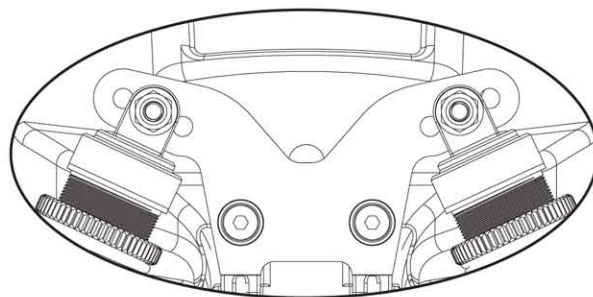

## Rear Camber

The usual team setting for static rear camber is 1-2° negative at ride height (the top of the tyre leaning inwards towards the car). Increasing the static rear camber will increase the traction when exiting the turns, but will be less stable at high speed. Decreasing the camber will reduce stability and traction in the turns but will be more stable at high speed. (Some drivers believe that adding slight positive camber where the tyre leans out at the top away from the car, will improve straight line traction on loose surfaces)

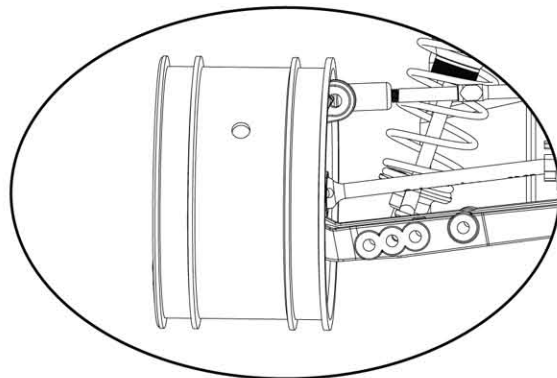

## Rear Camber Links

The kit build rear camber link setting is the best compromise for most tracks. This link option gives good stability and straight line traction while allowing the rear of the car to free up on high speed turns. This reduces power-on understeer on high grip tracks.

Shortening the rear camber link will make the rear of the car roll less in the corners and square up faster when accelerating away from tight turns, longer links are generally used on high grip tracks and shorter links on low grip tracks. Lowering the inside ball stud will give a similar result to shortening the link, and raising it will give a similar result to lengthening the camber link, but with less total effect.

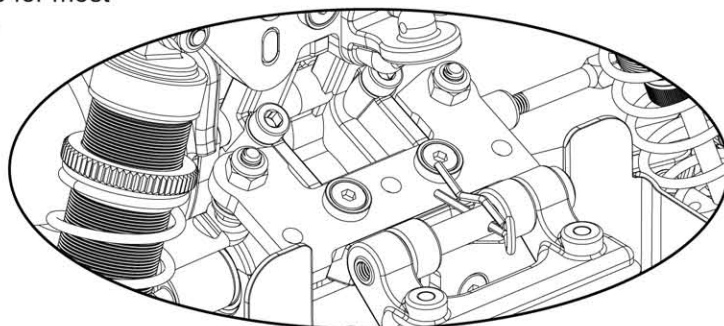

## Rear Anti-Squat

The standard anti-squat is 3°.

With optional parts this can be adjusted to 2°, 1° or 0°.

Anti-squat allows the suspension to work better over the large bumps but usually gives less power on traction. Adding more anti-squat gives more forward traction up to the point where the car starts to pull wheelies. Backing off the slipper is not always an option to compensate for this as good initial bite is needed to clear big jumps. Adding anti-squat seems to make the car handle better over small ripples but not so good on the tracks with large bumps. The Team have found that 3° works well on most tracks.

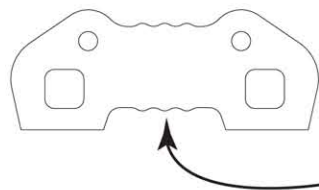

The C/F plates have bumps underneath to indicate how much anti-squat you are running, three bumps = 3°

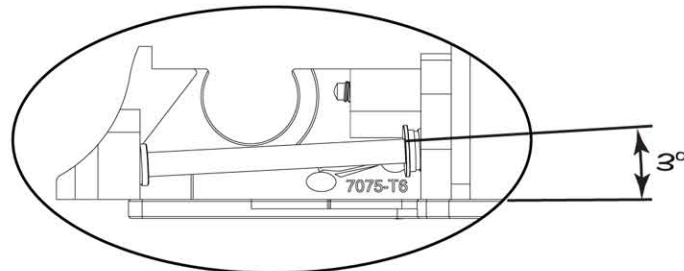
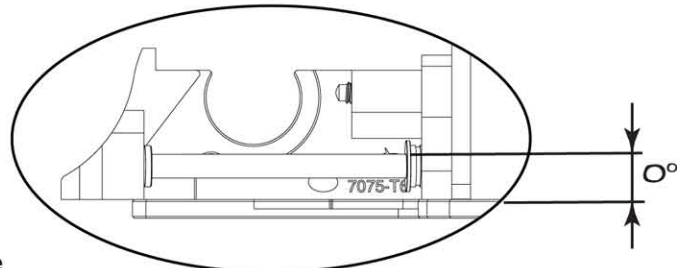

## Rear Wishbone Shock mounting Hole

The Middle hole works best for most track conditions giving good traction and drive through the turns whilst maintaining good stability over the bumps. Moving to the outer hole on the wishbone will decrease traction but will allow the rear to free up more in the turns. This setting would usually only get used on high grip tracks and when moving the shock out you may have to change the oil and spring settings to get the same suspension feel.

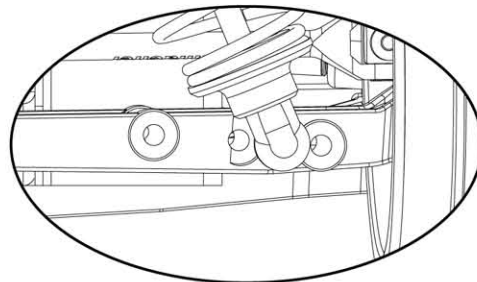

## Speed Secrets - Anti Roll Bar

Anti roll bars are an often overlooked set up aid that allows fine tuning of the suspension without major changes to the shock and spring settings. They are mainly used to add roll stiffness to the car without affecting the handling on bumps and jumps. Running roll bars allows you to run softer suspension on bumpy tracks while reducing the roll in corners thus maintaining stability through the turns.

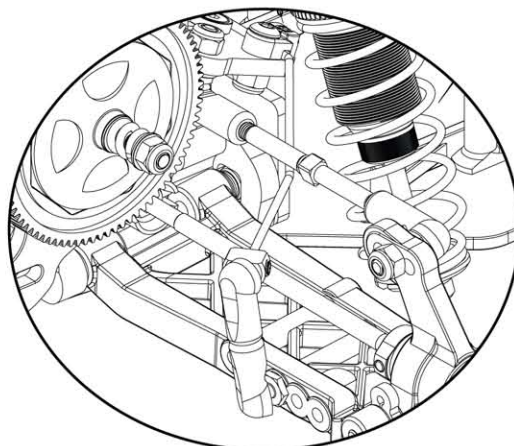

## Rear Toe In

The standard rear toe in is 3°, this is a good compromise between forward traction and the car binding in the turns, this setting is fine for most tracks. If you are running too much toe-in your car may suffer from instability at high speeds, decreasing the toe in will reduce forward traction but will free the car up in the turns. Usually the Team use less toe in on high grip tracks and more for low grip tracks.

The C/F plates have bumps on top to indicate how much rear toe-in you are running.  
Three bumps = 3°

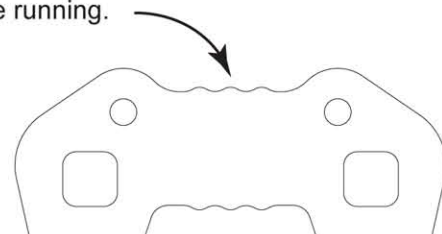

## Wheelbase Options

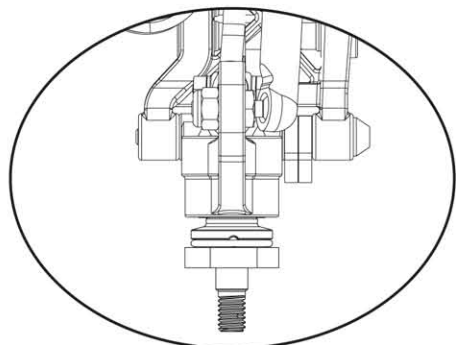

Long  
Wheelbase

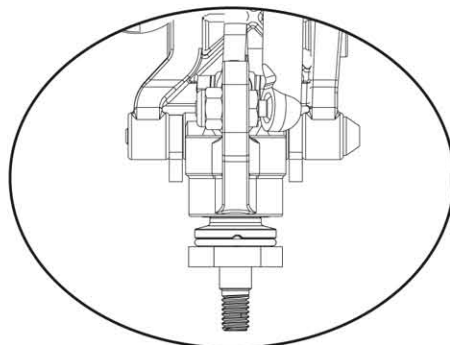

Med  
Wheelbase

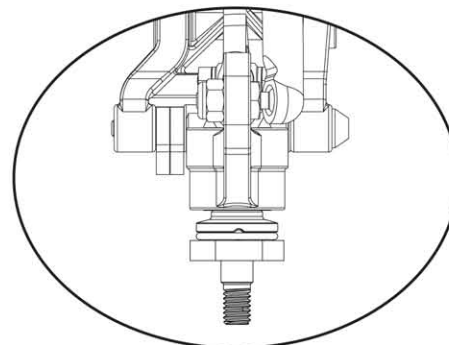

Short  
Wheelbase

The Cougar KR has 3 wheelbase options, short, med and long. This is adjusted by repositioning the kwik clips at the rear hub carrier. Both clips at the rear moves the hub forwards for short wheelbase. Both at the front for long wheelbase and one either side for med wheelbase. Running the car in short wheelbase will give more traction at the expense of stability over rough sections of the track. For better stability over the rough section run the car in long wheelbase form this will also free up the car on sweeping sections of the track.



### Rear Shock Mount

The middle hole on the shock mount gives best all round results. Moving the shock to the outer hole will stiffen the suspension and increase the reaction of the steering. The downside is less compliance over bumpy sections of the track. Moving the shock to the inboard position softens the suspension and will slow the steering reaction making the car smoother over the bumps. Moving the shock to these holes may require an oil or spring change to maintain the suspension performance.

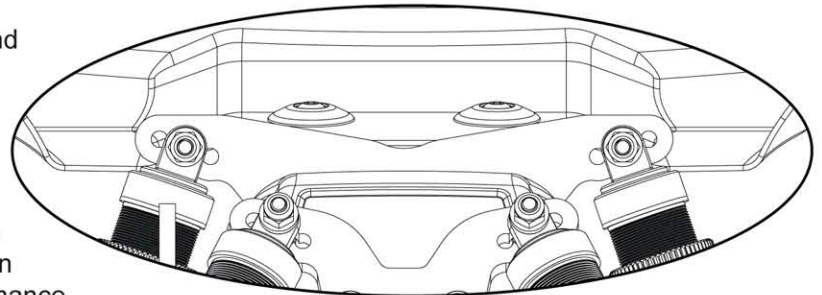

### Ride height

Use the spring adjusters on the shock absorbers to adjust the front and rear ride heights.

We would recommend setting the ride height to around 23 mm with the car level. This is measured between the bottom of the chassis and the ground with the car in running trim. First press the car down on to the ground and release it once or twice to settle the suspension before adjusting the ride height. The chassis should be level when viewed from the side. Adjusting the spring collars does not increase or decrease the spring stiffness only the preload. So if the suspension needs to be softer or harder change the spring.

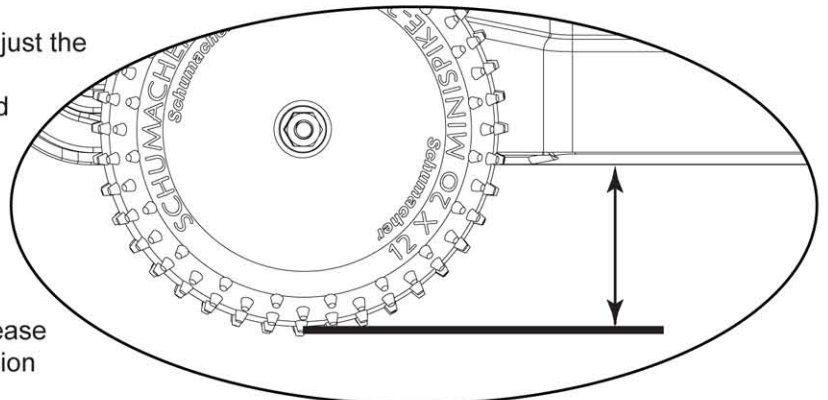

### Gear Ratio Chart

The Two Internal Gears in the Transmission are a 15 Tooth Layshaft Gear and 38 Tooth Differential Gear. This makes the internal Gear ratio 2.53:1

The Below chart is the overall Ratios including the Spur Gear and Pinion Options.

The Maximum Tooth Sum Available is 112 teeth, the minimum is 98 teeth.

	16	17	18	19	20	21	22	23	24	25	26	27	28	29	30	31	32
83	13.12	12.35	11.67	11.05	10.50	10.00	9.55	9.13	8.75	8.40	8.08	7.78	7.50	7.24			
82	12.97	12.20	11.53	10.92	10.37	9.88	9.43	9.02	8.64	8.30	7.98	7.68	7.41	7.15	6.92		
81		12.05	11.39	10.79	10.25	9.76	9.32	8.91	8.54	8.20	7.88	7.59	7.32	7.07	6.83	6.61	
80			11.24	10.65	10.12	9.64	9.20	8.80	8.43	8.10	7.78	7.50	7.23	6.98	6.75	6.53	6.33
76							8.74	8.36	8.01	7.69	7.39	7.12	6.86	6.63	6.40	6.20	6.00

- U3414 Pinion; Hard Alloy 48dp - 14T
- U3415 Pinion; Hard Alloy 48dp - 15T
- U3416 Pinion; Hard Alloy 48dp - 16T
- U3417 Pinion; Hard Alloy 48dp - 17T
- U3418 Pinion; Hard Alloy 48dp - 18T
- U3419 Pinion; Hard Alloy 48dp - 19T
- U3420 Pinion; Hard Alloy 48dp - 20T
- U3421 Pinion; Hard Alloy 48dp - 21T
- U3422 Pinion; Hard Alloy 48dp - 22T
- U3423 Pinion; Hard Alloy 48dp - 23T
- U3424 Pinion; Hard Alloy 48dp - 24T
- U3425 Pinion; Hard Alloy 48dp - 25T
- U3426 Pinion; Hard Alloy 48dp - 26T
- U3427 Pinion; Hard Alloy 48dp - 27T
- U3428 Pinion; Hard Alloy 48dp - 28T
- U3429 Pinion; Hard Alloy 48dp - 29T
- U3430 Pinion; Hard Alloy 48dp - 30T
- U3431 Pinion; Hard Alloy 48dp - 31T
- U3432 Pinion; Hard Alloy 48dp - 32T

- U2305 16T Steel Pinion - 48 D.P.
- U2306 17T Steel Pinion - 48 D.P.
- U2307 18T Steel Pinion - 48 D.P.
- U2308 19T Steel Pinion - 48 D.P.
- U2309 20T Steel Pinion - 48 D.P.
- U2310 21T Steel Pinion - 48 D.P.
- U2311 22T Steel Pinion - 48 D.P.
- U2312 23T Steel Pinion - 48 D.P.
- U2313 24T Steel Pinion - 48 D.P.
- U2314 25T Steel Pinion - 48 D.P.
- U2315 26T Steel Pinion - 48 D.P.
- U2316 27T Steel Pinion - 48 D.P.
- U2318 29T Steel Pinion - 48 D.P.

- U3348 Gear; CNC 80t Spur - Slipper
- U3349 Gear; CNC 81t Spur - Slipper
- U3350 Gear; CNC 82t Spur - Slipper
- U3351 Gear; CNC 83t Spur - Slipper
- U3790 Gear; CNC 76T Spur - Slipper
- U4226 Gear; CNC 71T Spur - Slipper



**Assembled Small Bore Shocks**  
 U4152 - Front  
 U4153 - Rear

U4211 C/F Strap 0deg antisquat - 2deg Toe-In - SVR  
 U4212 C/F Strap 1deg antisquat - 2deg Toe-In - SVR  
 U4213 C/F Strap 2deg antisquat - 2deg Toe-In - SVR  
 U4214 C/F Strap 3deg antisquat - 2deg Toe-In - SVR

U4081 C/F Strap 0deg antisquat - 3deg Toe-in - SVR  
 U4096 C/F Strap 1deg antisquat - 3deg Toe-in - SVR  
 U4097 C/F Strap 2deg antisquat - 3deg Toe-in - SVR

U3758  
 Steering Yokes 5 degree

U3605  
 CNC Alloy Rear Hubs  
 1 degree (pair)

Purple Titanium Turnbuckles (pair)  
 U1573 - 53mm  
 U1574 - 60mm  
 U2566 - 45mm

U4085  
 Roll Bar Set

**CORE RC**  
 Serrated M4 Nuts  
 CR024 - Steel pk4  
 CR035 - Alloy Blue pk4  
 CR036 - Alloy Violet pk4  
 CR196 - Alloy Black pk4

U1300  
 Axle Grease  
 The best general grease for many applications.

U1301  
 Silicone Diff Lube  
 The best lube for ball diffs!

U1957  
 Moly Grease  
 The ultimate thrust race grease!

**Schumacher**  
 Big Bore Spring Tuning Sets  
 U3673 - Medium (7 pairs)  
 U3674 - Long (6 pairs)

**CORE RC**  
 CR177 Big Bore Spring Tuning Set; Med 5prs  
 CR178 Big Bore Spring Tuning Set; Long 5prs

U3782  
 HD Shock Diaphragms

Big Bore Standard Shock Pistons  
 U3670 - 2 Hole Pistons (pair)  
 U3671 - 4 Hole Pistons (pair)  
 U3672 - 6 Hole Pistons (pair)

Big Bore Rounded Shock Pistons  
 U3770 - 3 Hole Pistons (pair)  
 U3771 - 5 Hole Pistons (pair)

U4130 - Vented Shock Caps - Small Bore - (Pr)  
 U4209 - Vented Shock Caps - Big Bore - (Pr)

Medium Flex Wishbones  
 U4098 - Front Long (pair)  
 U4054 - Rear (pair)

U2856  
 Sticky Cable Clips  
 Pack of 10

G200  
 ZX1 ExtraLube  
 The Ultimate Friction Eliminator.

U3611 CNC Alloy Spring Seat (pair)

U1954 Pro - Thrust Bearing  
 U3019 Diff Balls; Ceramic Nitride 2.5mm (pk12)  
 U3740 Diff Washers; 18mm - Cougar SV  
 U3855 Ball Bearing 5x10x3 Open (pr)  
 U4004 Diff Gear; 38T CNC - Cougar SV2  
 U4005 Diff Output; Female - Cougar SV2  
 U4006 Diff Output; Male - Cougar SV2  
 U4007 Diff; Assembled Pro Spec - Cougar SV2  
 U4040 Diff Screw Set Cougar SV2

U4394 Carbon Fibre Link Mount Options Front & Rear (Set 5)

**CORE RC**  
 CR192 Alloy Servo Arm 25T - Futaba Short  
 CR193 Alloy Servo Arm 23T - Sanwa Short

U4228 Alloy Yokes  
 2WD - 5deg - Cougar



2WD Slim Cut Stagger



U6759 - Yellow Compound (pair)  
U6765 - Green Compound (pair)

Low Profile  
2WD Slim Cut Stagger



U6770 - Yellow Compound (pair)  
U6771 - Green Compound (pair)  
U6775 - Silver Compound (pair)  
U6776 - Blue Compound (pair)

2WD Slim Mini Spike 2



U6549 - Blue Compound (pair)  
U6550 - Green Compound (pair)  
U6581 - Yellow Compound (pair)  
U6761 - Silver Compound (pair)

2WD Slim Mini Pin



U6609 - Yellow Compound (pair)  
U6779 - Silver Compound (pair)

Rear Mini Spike 2



U6516 - Green Compound (pair)  
U6518 - Blue Compound (pair)  
U6558 - Yellow Compound (pair)  
U6763 - Silver Compound (pair)

2.2" Rear Full Spike



U6596 - Yellow Compound (pair)

Front Mini Spike 2



U6515 - Green Compound (pair)  
U6517 - Blue Compound (pair)  
U6557 - Yellow Compound (pair)  
U6762 - Silver Compound (pair)

4WD Front Mini Pin



U6601 - Blue Compound (pair)  
U6607 - Yellow Compound (pair)  
U6777 - Silver Compound (pair)

## Wheels

- U4365 Wheel Hex Rear - (black) - Off Road
- U4366 Wheel Hex Rear - (white) - Off Road
- U4367 Wheel Hex Front - (black) - 2wd
- U4368 Wheel Hex Front - (white) - 2wd



4wd Rear 2" Block



T692 - Blue Compound (pair)  
U6786 - Yellow Compound (pair)

Rear Mini Pin



U6608 - Yellow Compound (pair)  
U6602 - Blue Compound (pair)  
U6778 - Silver Compound (pair)

		Tarmac	Carpet	Dry Astro	Dry Grass	Wet Grass	Wet Astro
2wd Slim Cut Stagger	U6759		●●	●●●	●●●		
	U6765					●●●	●●
2wd Low Profile Slim Cut Stagger	U6770		●●	●●●	●●●		
	U6771					●●●	●●
	U6775					●●	●●●
	U6776	●●					
2wd Slim Mini Spike 2	U6581		●●	●●●	●●●		
	U6550			●		●●●	●●
	U6549	●●				●●	●●●
	U6761					●●	●●●
2wd Slim Mini Pin	U6609	●	●●●	●●			
	U6779					●●	●●●
4wd Front Mini Spike 2	U6557	●	●●	●●●	●●●		
	U6517	●●				●●●	
	U6515			●		●●●	●●
	U6762					●●	●●●
4wd Front Mini Pin	U6607	●	●●●	●●			
	U6601	●●●	●				●●●
	U6777					●●	●●●
2.2" Rear Full Spike	U6596				●●		
Rear Mini Spike 2	U6558	●	●	●●●	●●●		
	U6518	●●●			●●	●●	
	U6516			●		●●●	●●
	U6763					●●	●●●
Rear Mini Pin	U6608	●	●●●	●●			
	U6602	●●●	●				
	U6778					●	●●●
Rear 2" Block	U692	●●					
	U6786			●●●			

Excellent Grip ●●● Good Grip ●● Fair Grip ●

## Off-Road Inserts

- CR141 Red Moulded Insert; 1/10 Off Rd Rear
- CR142 Red Moulded Insert; 1/10 Off Rd 4WD Front

- U6653 - GREY Foam Tyre Insert; Hard - Rear - CAT (pr)
- U6667 - GREY Foam Tyre Insert; Hard - Slim 2WD (pr)
- U6668 - WHITE Foam Tyre Inserts; Soft - Ultra Wide (pr)
- U6669 - GREY Foam Tyre Inserts; Hard - Ultra Wide (pr)
- U6733 - BLUE Foam Tyre Insert; Med - Front - CAT (pr)
- U6734 - BLUE Foam Tyre Insert; Med - Rear - CAT (pr)
- U6746 - BLUE Tubby Insert; Med Front - CAT (pr)
- U6747 - BLUE Tubby Insert; Med Rear - CAT (pr)
- U6738 - BLUE Foam Tyre Insert; Med - Slim 2WD (pr)

