

COUGAR LD3

PRO 1/10th 2WD Off-Road Buggy



Instruction Manual ISS01



www.racing-cars.com

Schumacher

71-73 Tenter Road
Moulton Park
Northampton
NN3 6AX

This manual contains build steps for all LD3 models. Any step unique to a particular model is identified by the following logos:

Key: LD3M = Modified, LD3S = Stock, LD3D = Dirt



IMPORTANT SAFETY NOTES

- We strongly recommend that anyone driving RC cars, or organising events, should obtain third party liability insurance. In the UK this can be done by joining the BRCA. www.brca.org
- This product is not suitable for children under the age of 14, without the direct supervision of a responsible adult.
- Select an area for assembly that is away from the reach of small children.
- The parts in this kit are small and can be swallowed by children causing choking and possible internal injuries.
- Exercise care when using hand tools and sharp instruments during assembly.
- Carefully read all manufacturers warnings and cautions for any additional items used in the construction.
- In line with our policy of continuous development the exact details of the kit may vary.
- DO NOT use this car on public roads or in places where it can interfere with traffic, people or animals.
- Always check the operation of the radio with the wheels off the ground, before using the car.
- Make sure the radio and car batteries are fully charged before use.
- Disconnect and remove the battery from the car when not in use.
- Always store and charge LiPo batteries in a fireproof container.
- DO NOT put fingers or any objects inside rotating or moving parts as this may cause injury.
- Make sure the charger is correctly set for the type of battery you are using.
- Incorrect charging may cause a fire.
- Insulate all exposed electrical wiring. Exposed or damaged wires can cause short circuits and fire.
- The motor and speed controller can become hot during use. DO NOT touch them immediately after using your car as this may cause injury.

ADDITIONAL ITEMS REQUIRED



Radio Equipment



Motor and Pinion Gear



2S Shorty LiPo



Battery Charger



Steering Servo



Electronic Speed Controller



Pro Tyre Glue



Polycarbonate Paint



Tyres and Inserts

TOOLS REQUIRED

1.5mm Hex Driver - U2789

2.0mm Hex Driver - U2790

2.5mm Hex Driver - U2791

5.5mm M3 Nut Driver - U2795

7.0mm M4 Nut Driver - U2796

Body Reamer - U2818

Pliers - CR528

Side Cutters - CR527

Soldering Iron - CR275

Solder - U3107

Curved Scissors - CR044



ICON KEYS

MOLY GREASE CR755 CORE RC Molybdenum Thrust Race Grease - 10ml - Pot - CR755

THREAD LOCK BLUE CR520 CORE RC Medium Thread Lock 3ml - CR520

CA GLUE CORE CR522 CORE RC 522 Pro Tyre Glue 20g + 2 Nozzles - CR522

LITHIUM GREASE CR752 CORE RC High Performance Lithium Grease - 10ml - CR752

SILICONE GREASE CR753 CORE RC Silicone Ball Diff Grease - 10ml - CR753



Caution/Important note. Please read.



Left-Hand Side of car



Right-Hand Side of car



Additional information that will help you build a faster race car.



Set up Sheet - Refer to page 36 for LD3M kit setup.

See website for LD3S and LD3D kit setups.



BAG A - Step 01

- A x2**
7.0x 1.0 Black 'O' Ring
- B x4**
Red 'O' Ring

Remove parts cleanly from sprue. File parts if necessary. Ensure the bush is not a tight fit in the shock body.

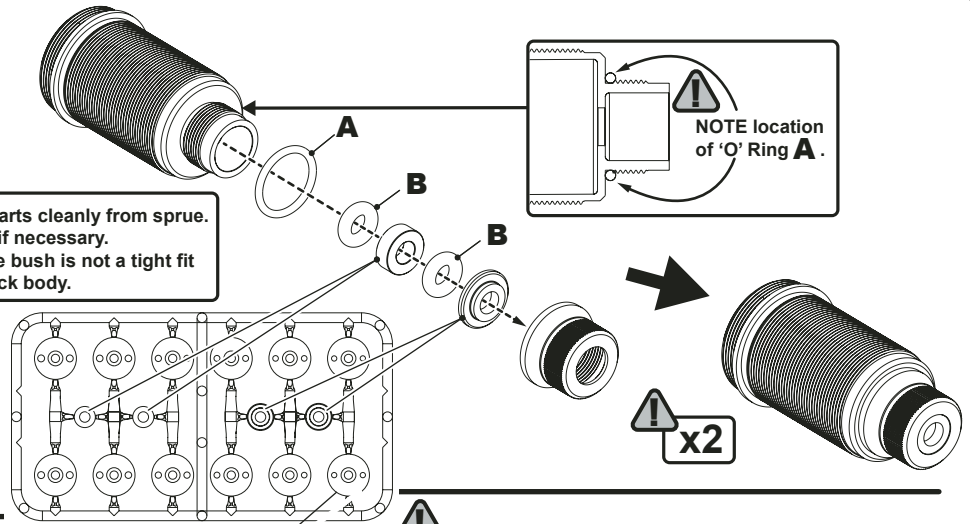
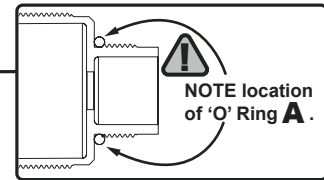

BAG A - Step 02

- A x2**
M 2.5x 8mm Csk Screw
- B x2**
Rod End Ball
- C x2**
Shock Piston Support

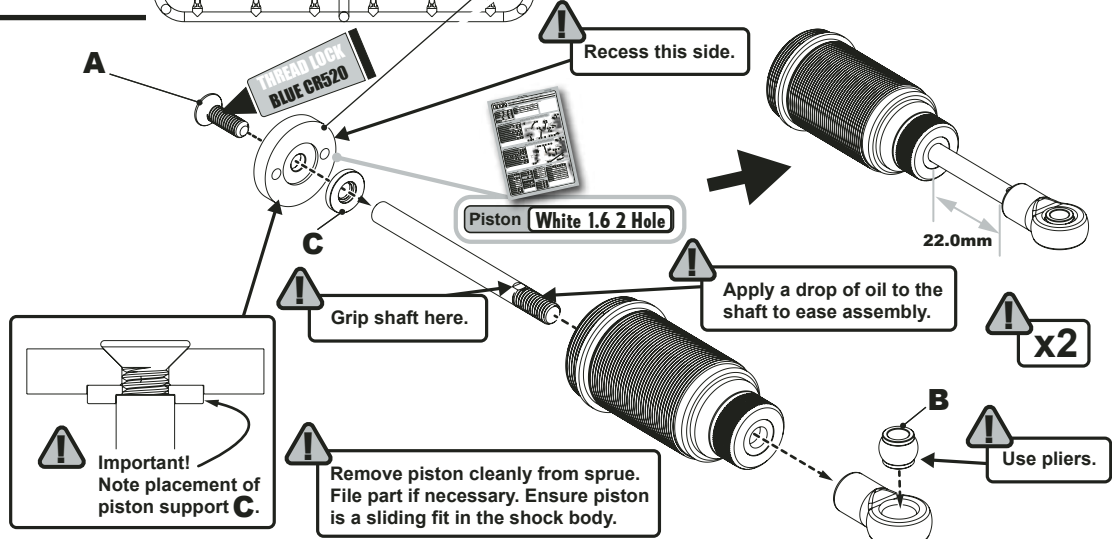

BAG A - Step 03

- A x2**
M2.5x 4 Button Hd Screw
- B x2**
'O' Ring Ø15 x 1.6
- C x2**
'O' Ring Ø12 x 1.6

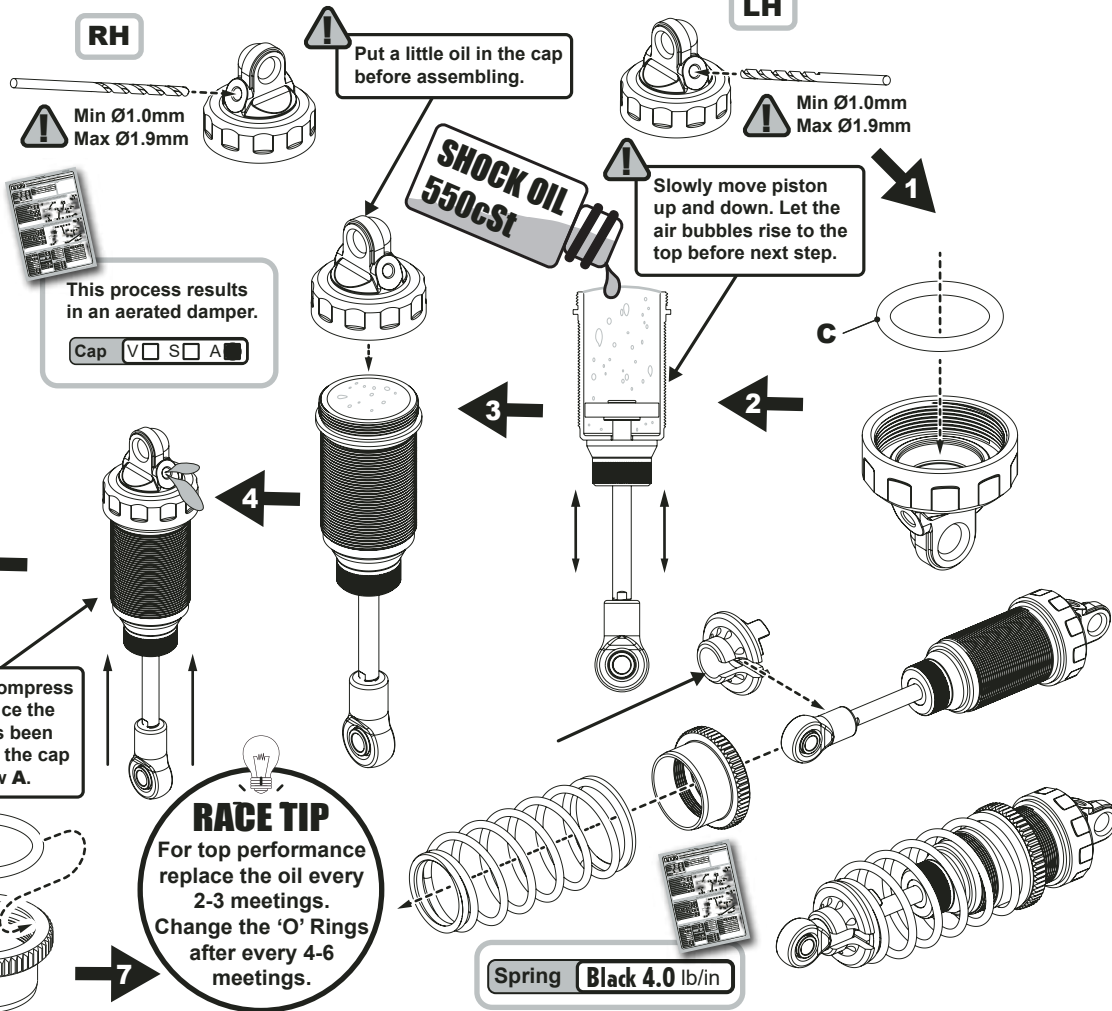



PRO 1/10th 2WD Off-Road Buggy

BAG A - Step 04

A x2
7.0x 1.0 Black 'O' Ring

B x4
Red 'O' Ring

Remove parts cleanly from sprue. File parts if necessary. Ensure the bush is not a tight fit in the shock body.

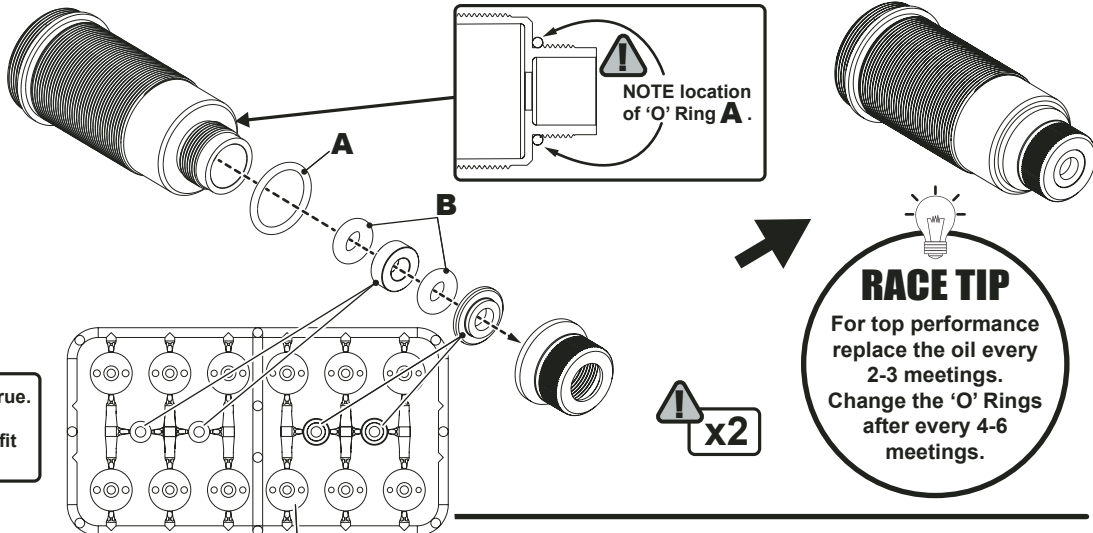

BAG A - Step 05

A x2
2.5x 8mm Csk Screw

B x2
Shock Piston Support

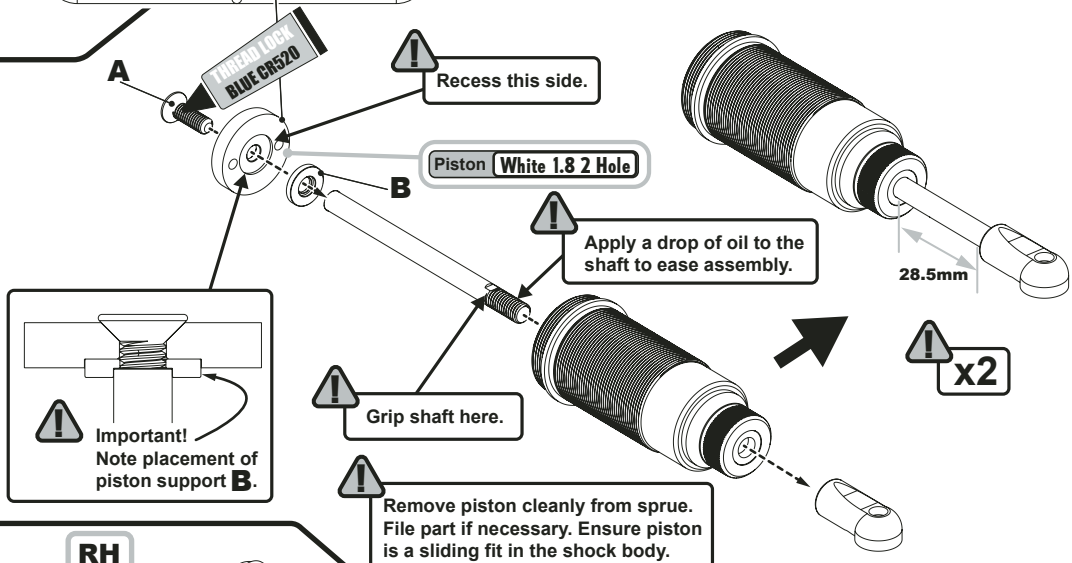

BAG A - Step 06

A x2
M2.5x 4 Button Hd Screw

B x2
'O' Ring Ø15 x 1.6

C x2
'O' Ring Ø12 x 1.6

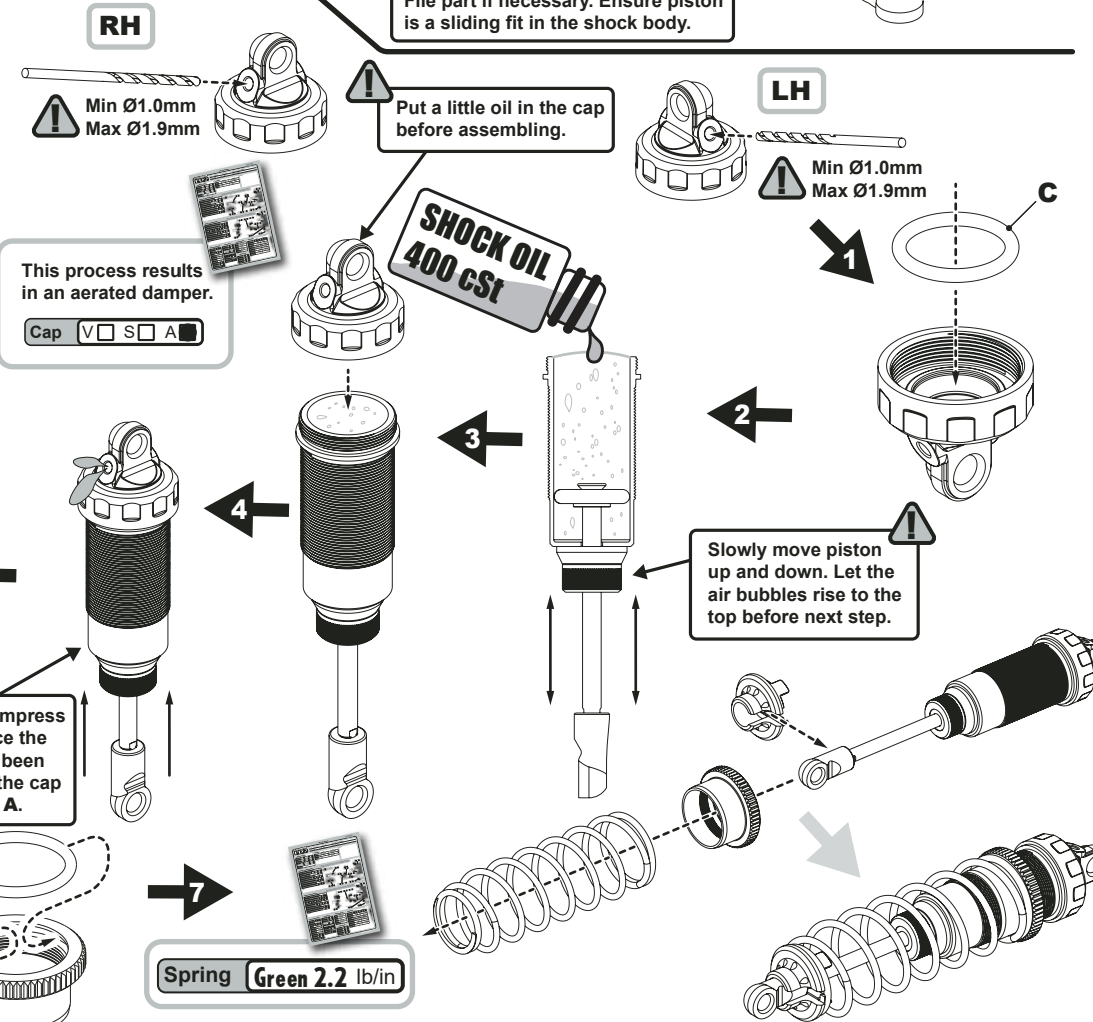

This process results in an aerated damper.

Cap V S A

BAG A - Step 07

- A x3**
Ø5 x Ø7 x 0.1mm Shim
- B x2**
Ø4 x Ø13 x 0.1mm Shim
- C x1**
Ø1.5 x 7.8 Pin
- D x1**
Ø4 x Ø13 x 0.5mm Shim
- E x1**
'O' Ring Ø3.69 x 1.8

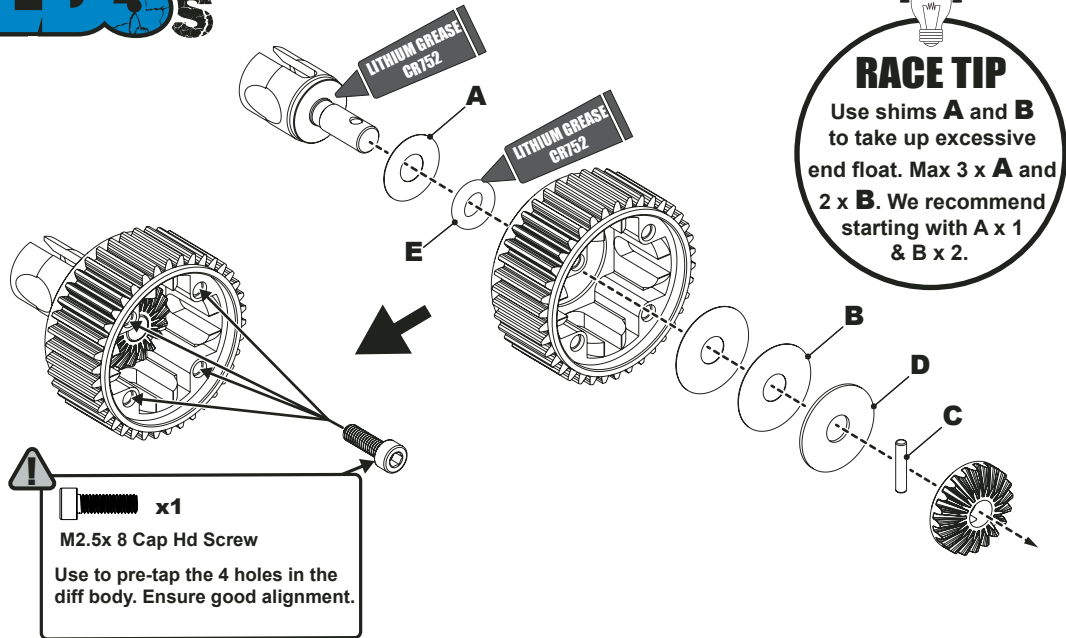

BAG A - Step 08

- A x3**
Ø5 x Ø7 x 0.1mm Shim
- B x2**
Ø4 x Ø13 x 0.1mm Shim
- C x1**
Ø1.5 x 7.8 Pin
- D x1**
Ø4 x Ø13 x 0.5mm Shim
- E x1**
'O' Ring Ø3.69 x 1.8

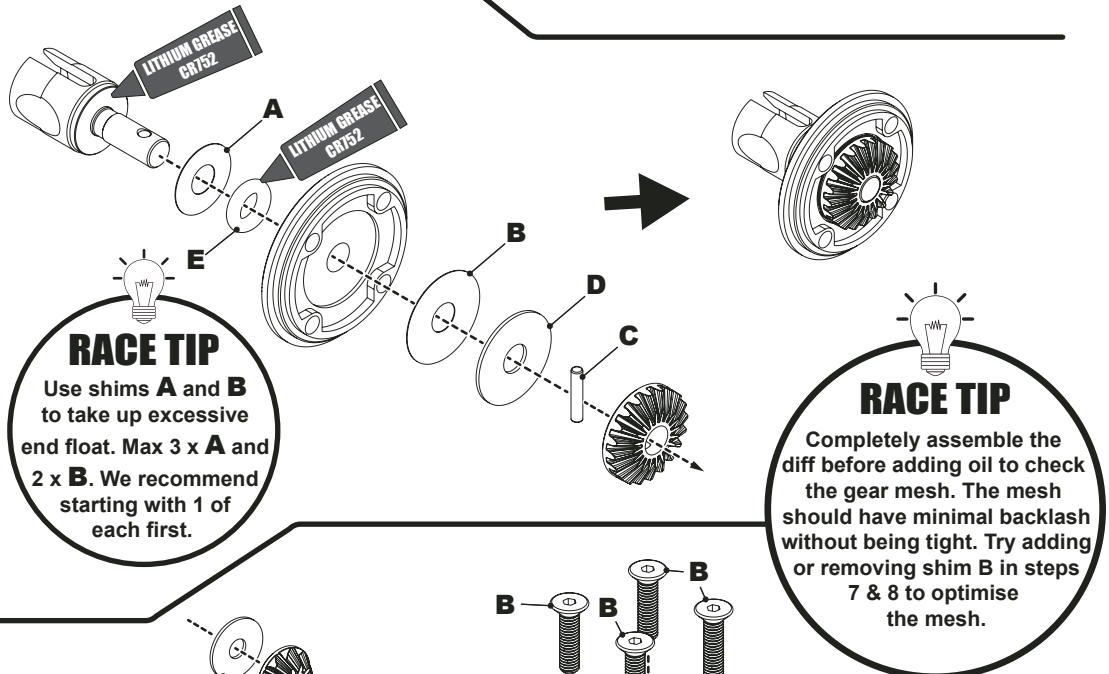

BAG A - Step 09

- A x2**
Ø3 x Ø9 x 0.5mm Shim
- B x4**
M2.5x 10 Csk Hd Screw
- C x1**
'O' Ring Ø21 x 1.0

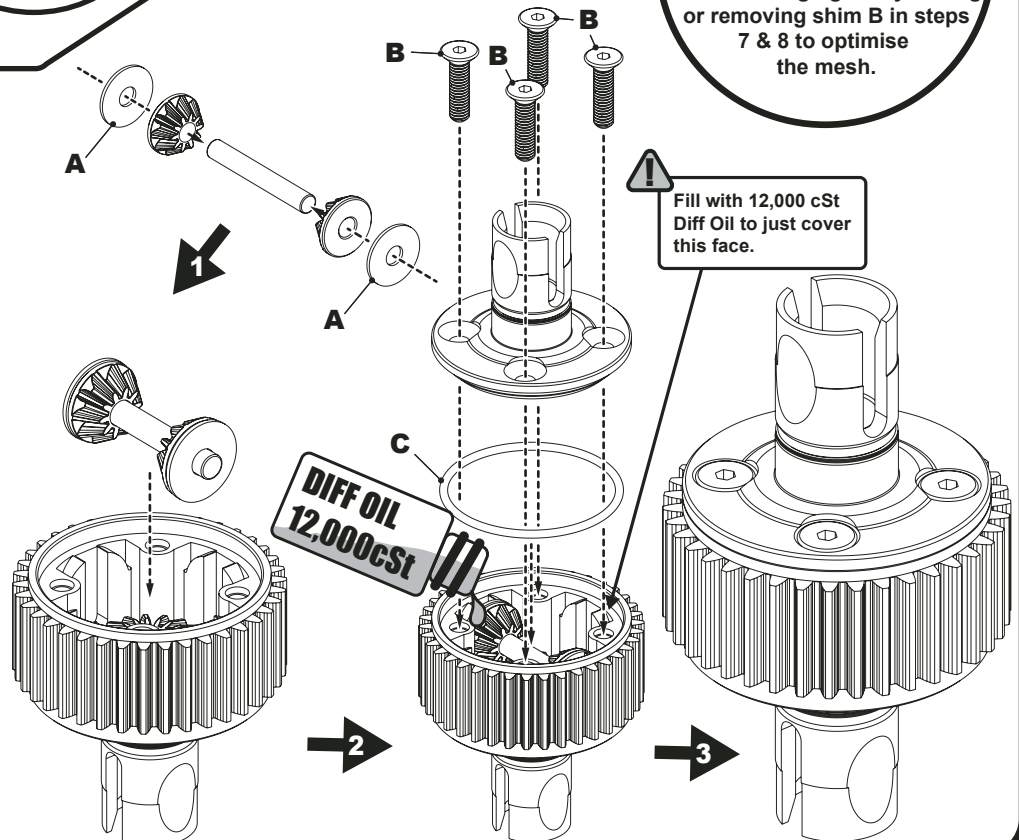

BAG A - Step 07

A x2

Ø5 x Ø10 x 3 Bearing

B x2

Ø5 x Ø7 x 0.45mm Shim



Ensure the diff washer is clean before applying silicone grease.

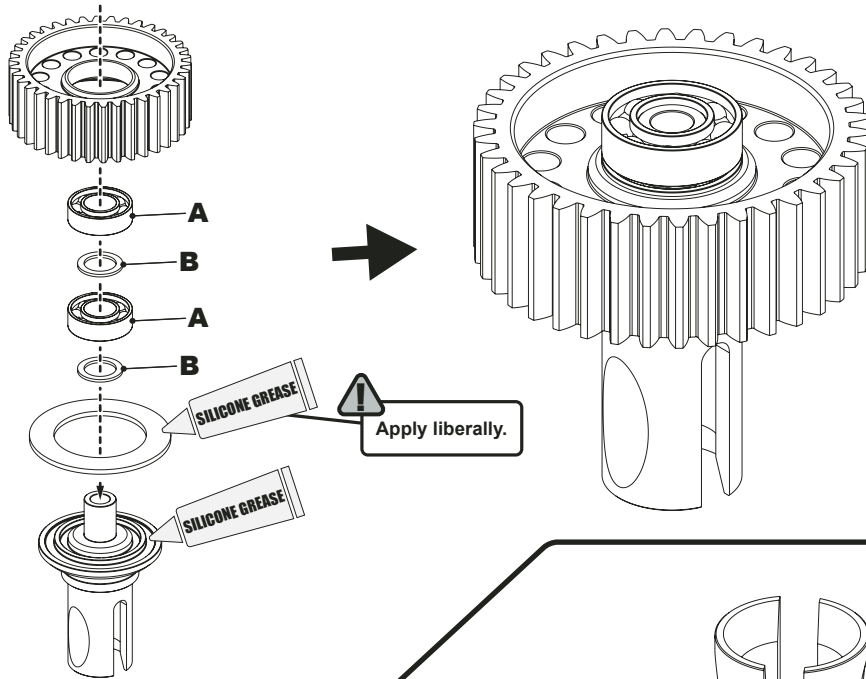

BAG A - Step 08

A x14

Ø2.5 Ball



Ensure the diff washer is clean before applying silicone grease.



Apply liberally.

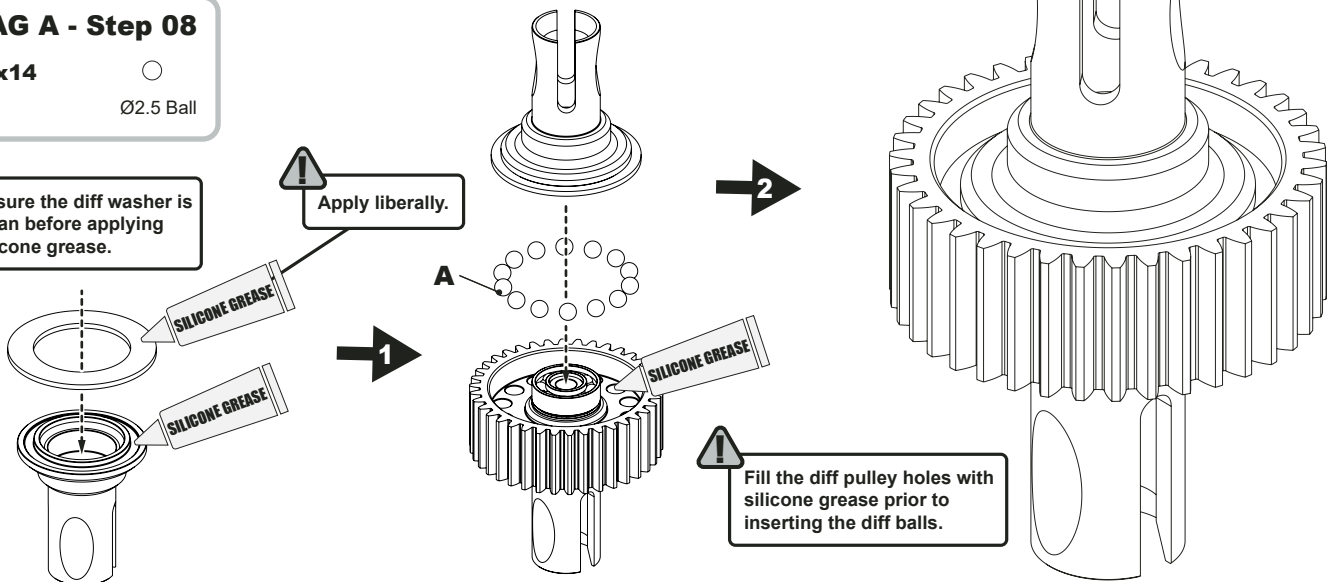

BAG A - Step 09

A x1

M2.5 x 25 Cap Hd screw

B x6

Ø2.0 Ball

C x1

Ø2.0 x 11.8 Pin



Use pin 'C' to align the t-nut insert with the t-nut to ease assembly. Screw 'A' will eject pin 'C' automatically during the assembly procedure.



Basic diff setting. Turn the screw in until the spring is fully compressed, then undo the screw between 90 and 120 degrees.

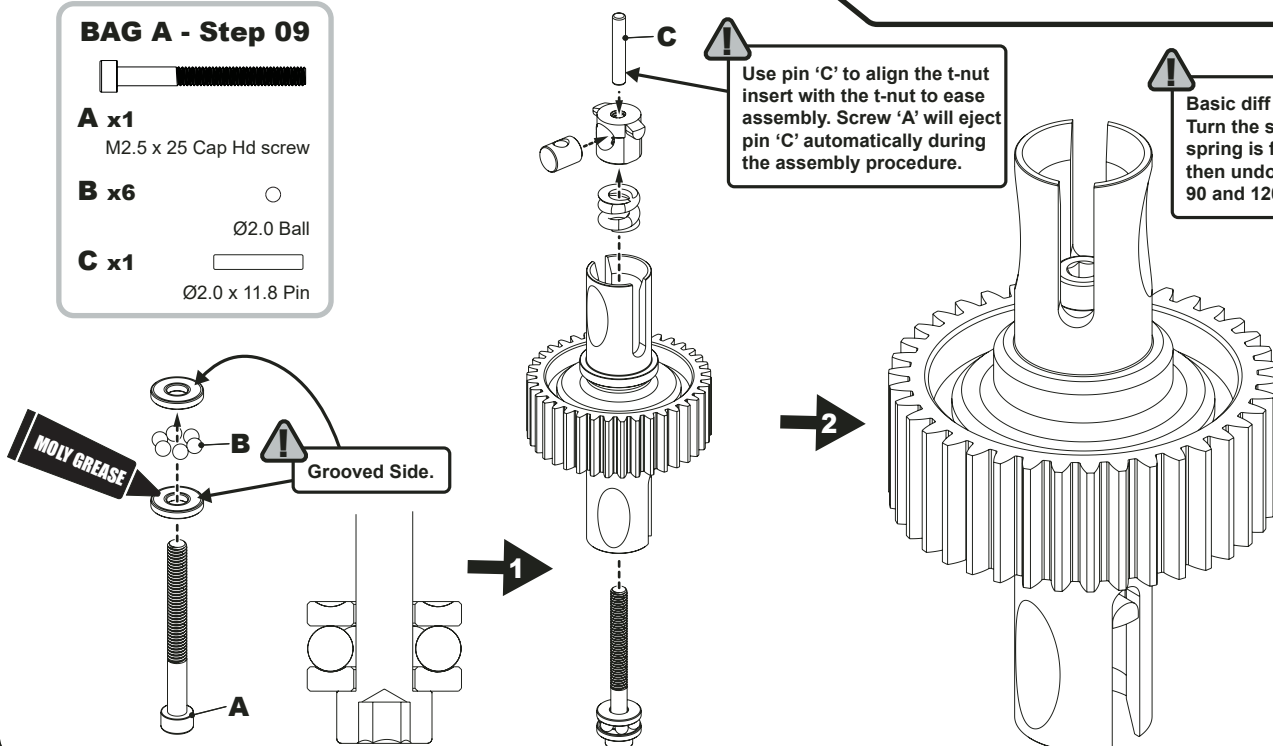



BAG B - Step 10a

Front Camber Link

RACE TIP
 Greasing the threads will make adjusting the turnbuckles easier. The tools used for assembly are in the s2 parts bag.

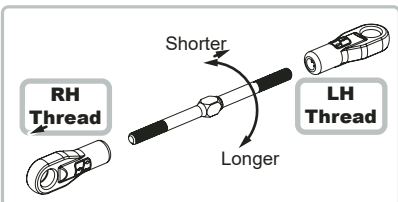

⚠ 52mm turnbuckle. Front Camber Link.

⚠ Note the shape of the turnbuckle. This side of the turnbuckle is the left hand thread.

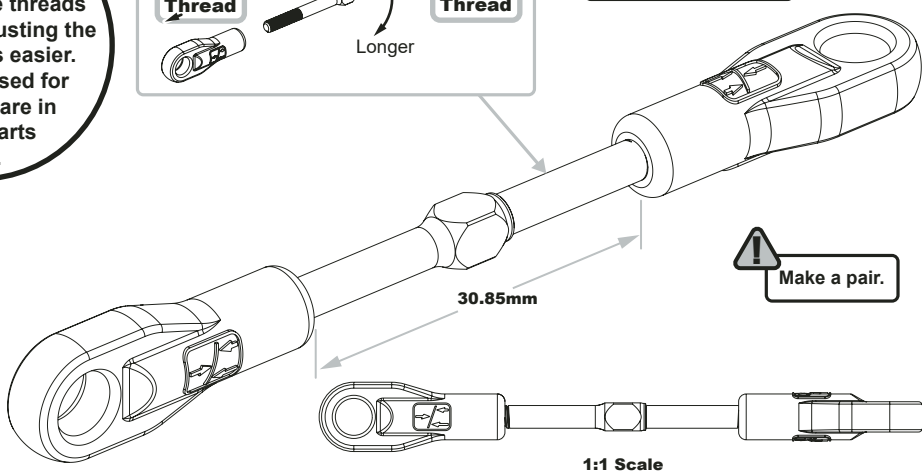

BAG B - Step 10b

Front Steering Link

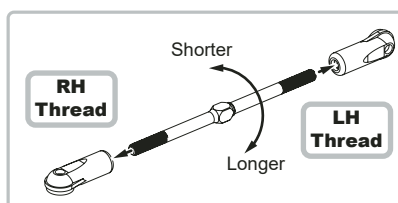

⚠ 60mm turnbuckle. Steering Link.

⚠ Note the shape of the turnbuckle. This side of the turnbuckle is the left hand thread.

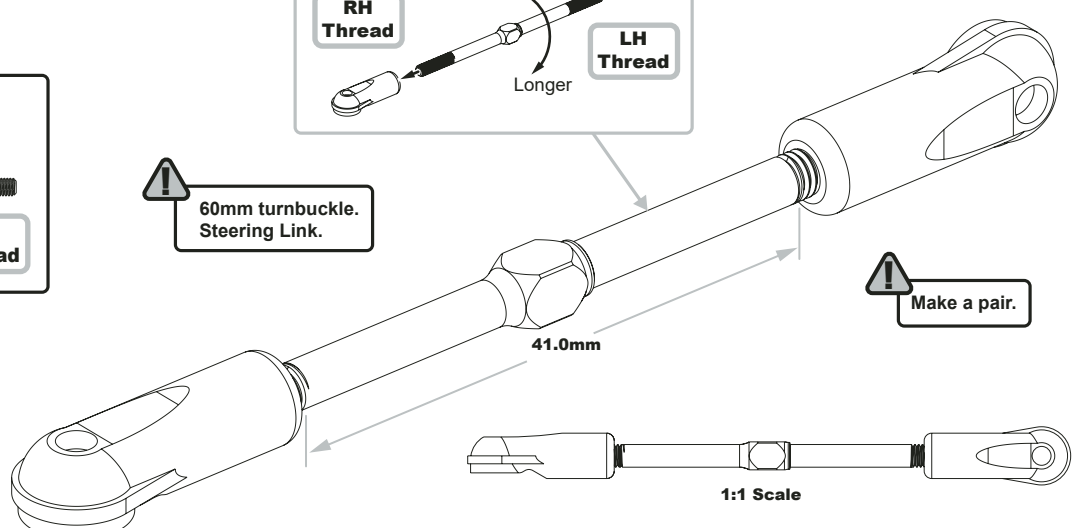

BAG B - Step 10c

Rear Camber Link

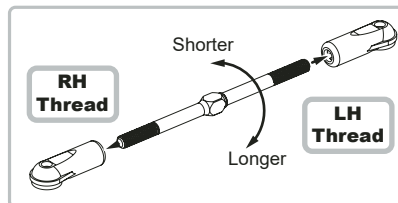



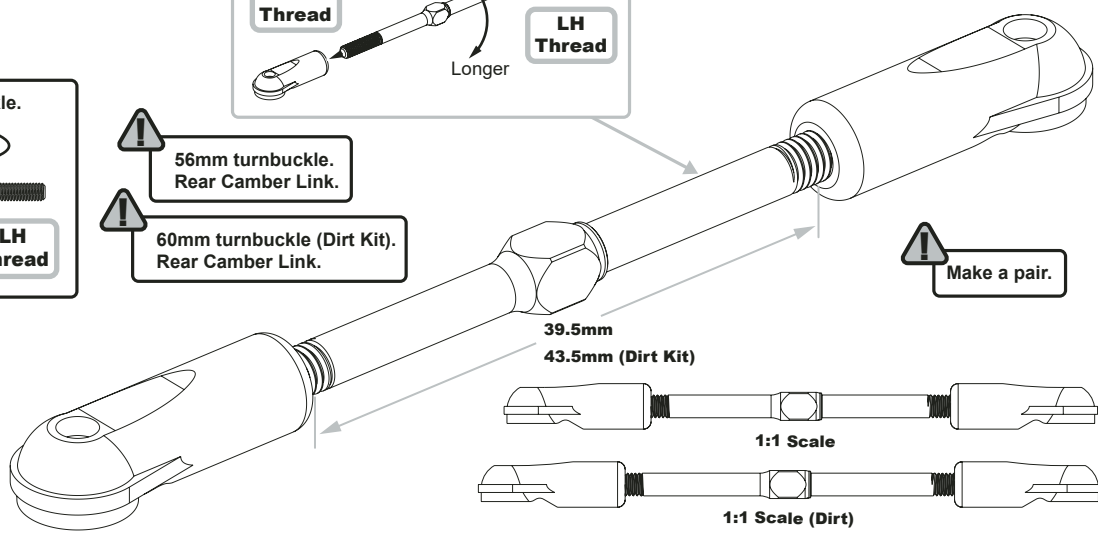

⚠ 56mm turnbuckle. Rear Camber Link.

⚠ 60mm turnbuckle (Dirt Kit). Rear Camber Link.

⚠ Note the shape of the turnbuckle. This side of the turnbuckle is the left hand thread.







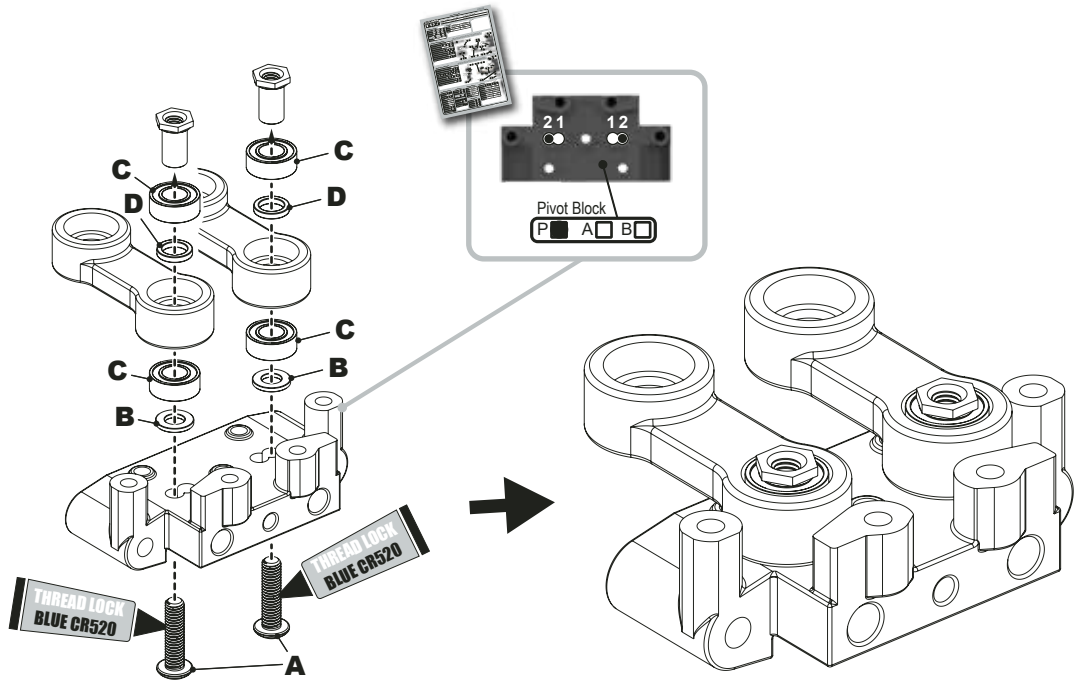

BAG B - Step 11

- A x2**  M3 x 12 Button Hd Screw
- B x2**  Black Alloy Washer 0.75mm
- C x4**  ø4 x ø8 x 3 Bearing
- D x2**  ø4 x ø5.6mm Shim



BAG B - Step 12

- A x2**  M3 x 12 Button Hd Screw
- B x2**  M3 Steel Washer
- C x2**  Black Alloy Washer 2.0mm
- D x4**  ø4 x ø8 x 3 Bearing
- E x2**  ø4 x ø5.6mm Shim
- F x1**  Black Ball Stud
- G x2**  Extra Long Ball Stud

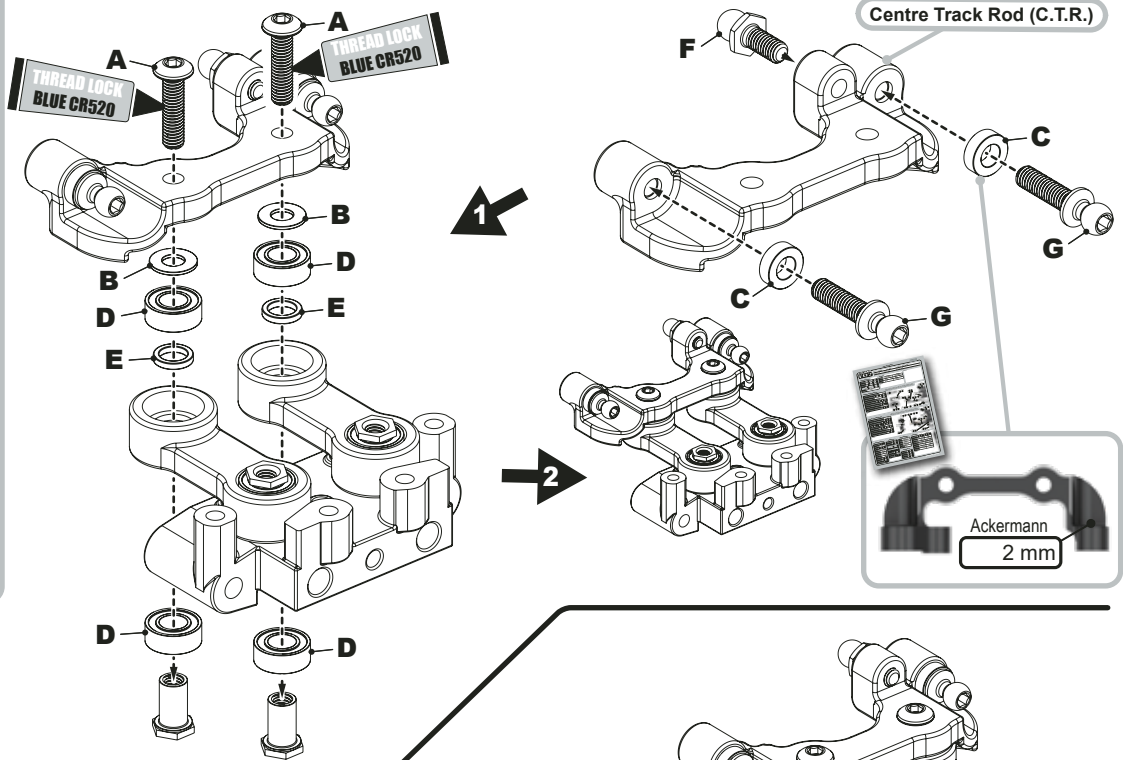

 Use a small amount of threadlock.

BAG B - Step 13

- A x3**  M3 x 10 Csk Hd Screw

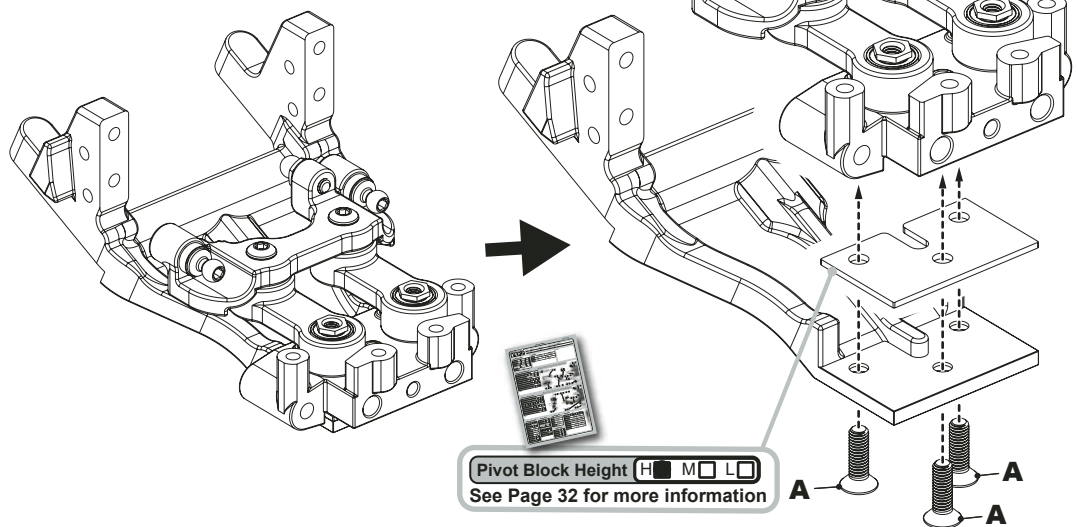

BAG B - Step 14a

- A x1**
M3 x 8 Button Hd Screw
- B x1**
Black Ball Stud

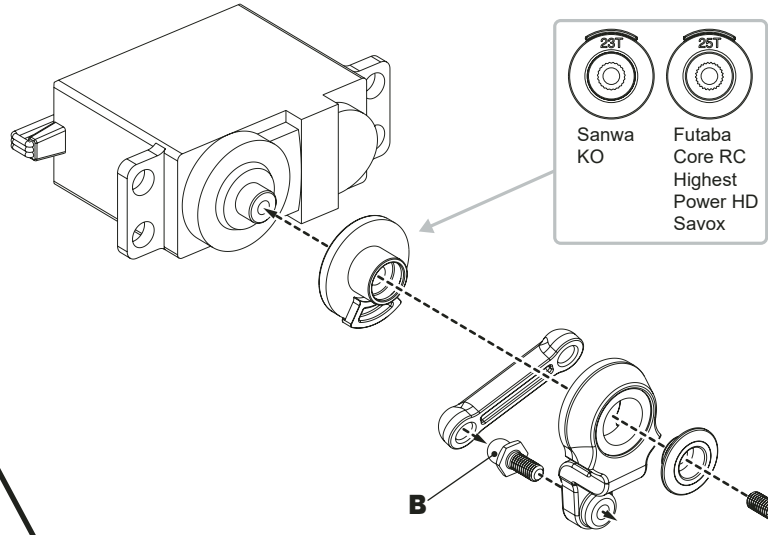

BAG B - Step 14b

- A x4**
M3 Steel Washer
- B x4**
M3 x 12 Button Hd Screw
- C x4**
M3 x 10 Button Hd Screw

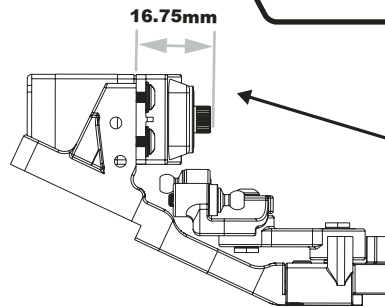







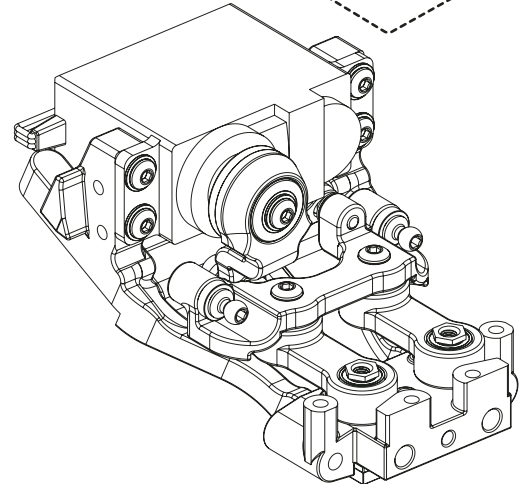
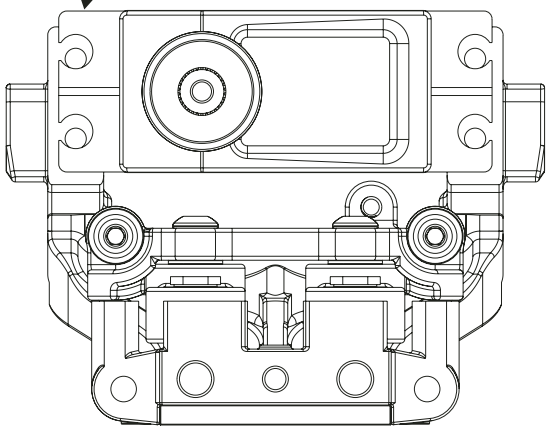
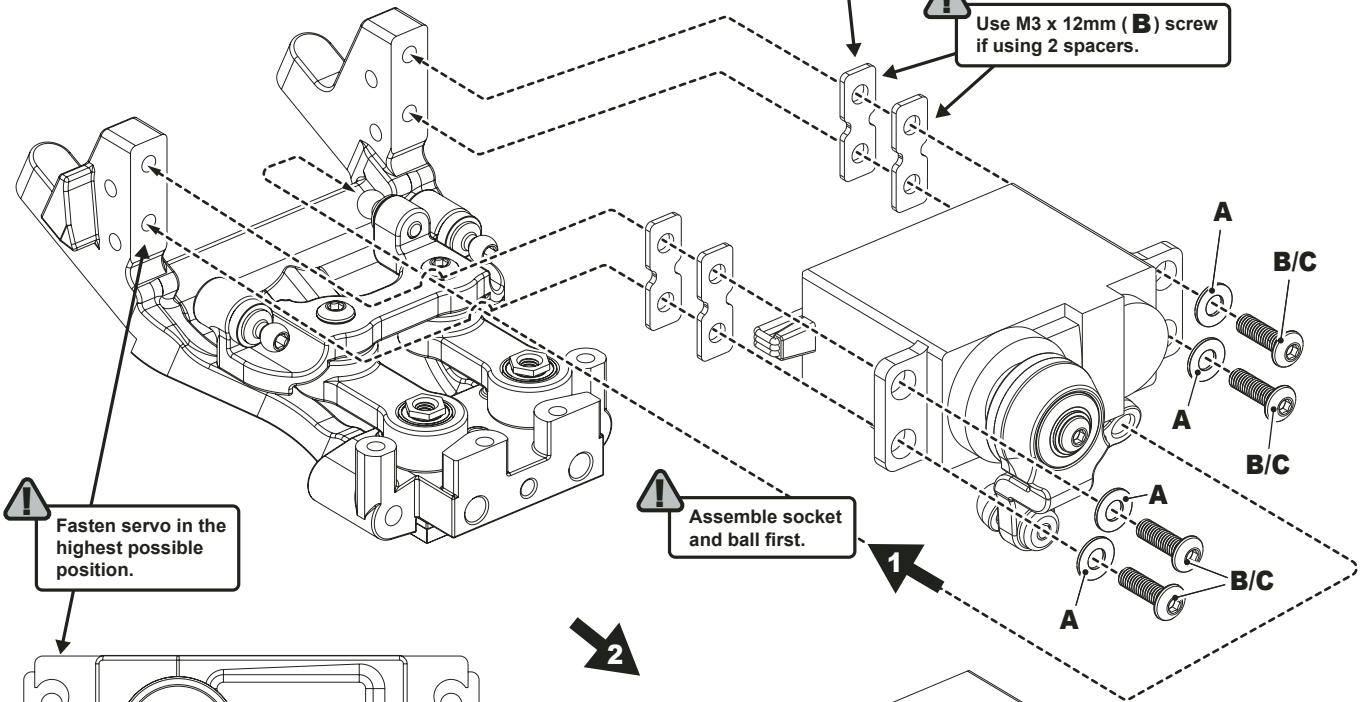

! Use this guide to space the servo each side. Try to achieve as close to 16.75mm as possible. To allow clearance for the centre track rod.

MANUFACTURER	SPACER
KO / Highest	1 x 1mm
Sanwa / Dash	2 x 1mm
Core RC	None

! Use M3 x 12mm (B) screw if using 2 spacers.



BAG B - Step 15



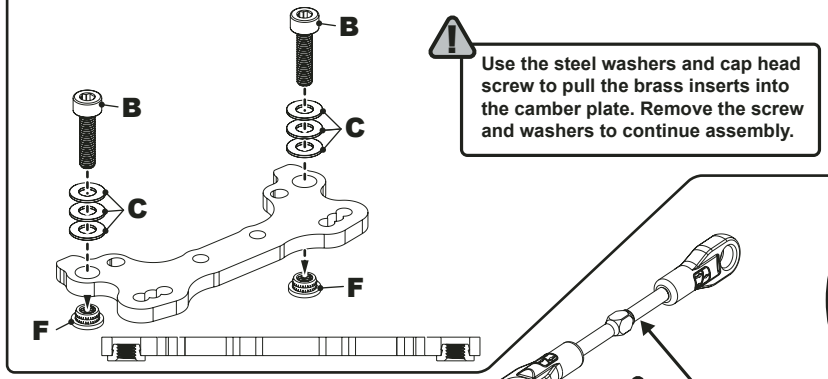

- A x2**  M3 x 10 Button Hd Screw
- B x1**  M3 x 12 Cap Hd Screw
- C x3**  M3 Steel Washer
- D x4**  Black Alloy Washer 1.0mm
- E x2**  Black Alloy Washer 2.0mm
- F x2**  M3 Thread Insert
- G x2**  M3 Nyloc
- H x2**  5.5mm Ball Stud Ex Long

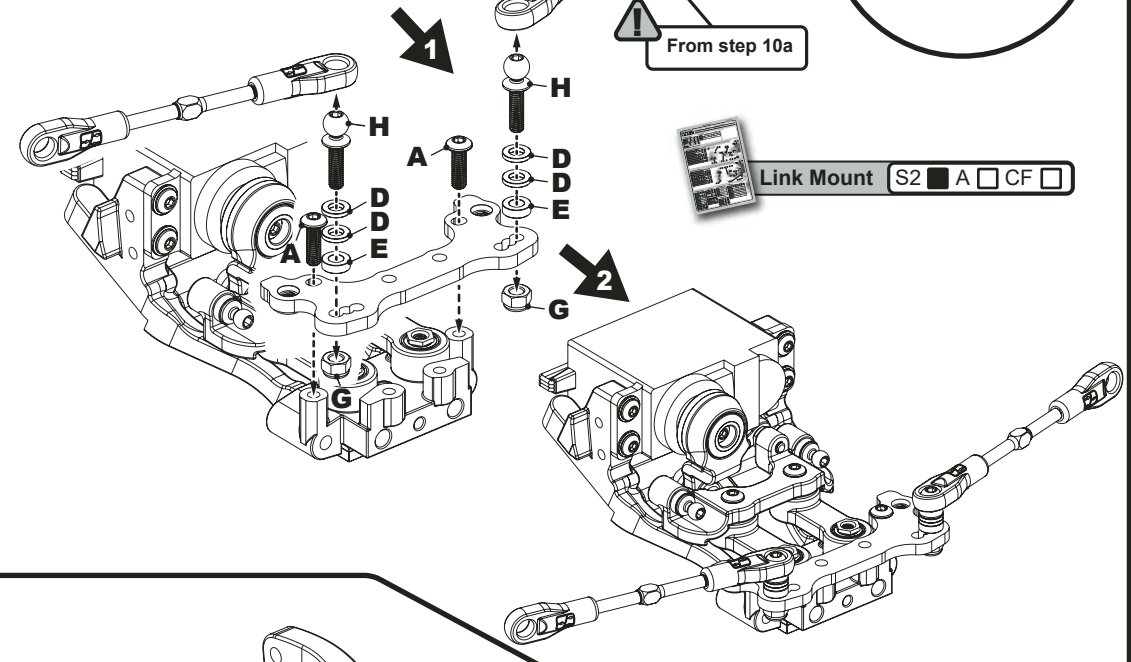

RACE TIP
Assemble the turnbuckles with the LH threads pointing to the LH side of the car.





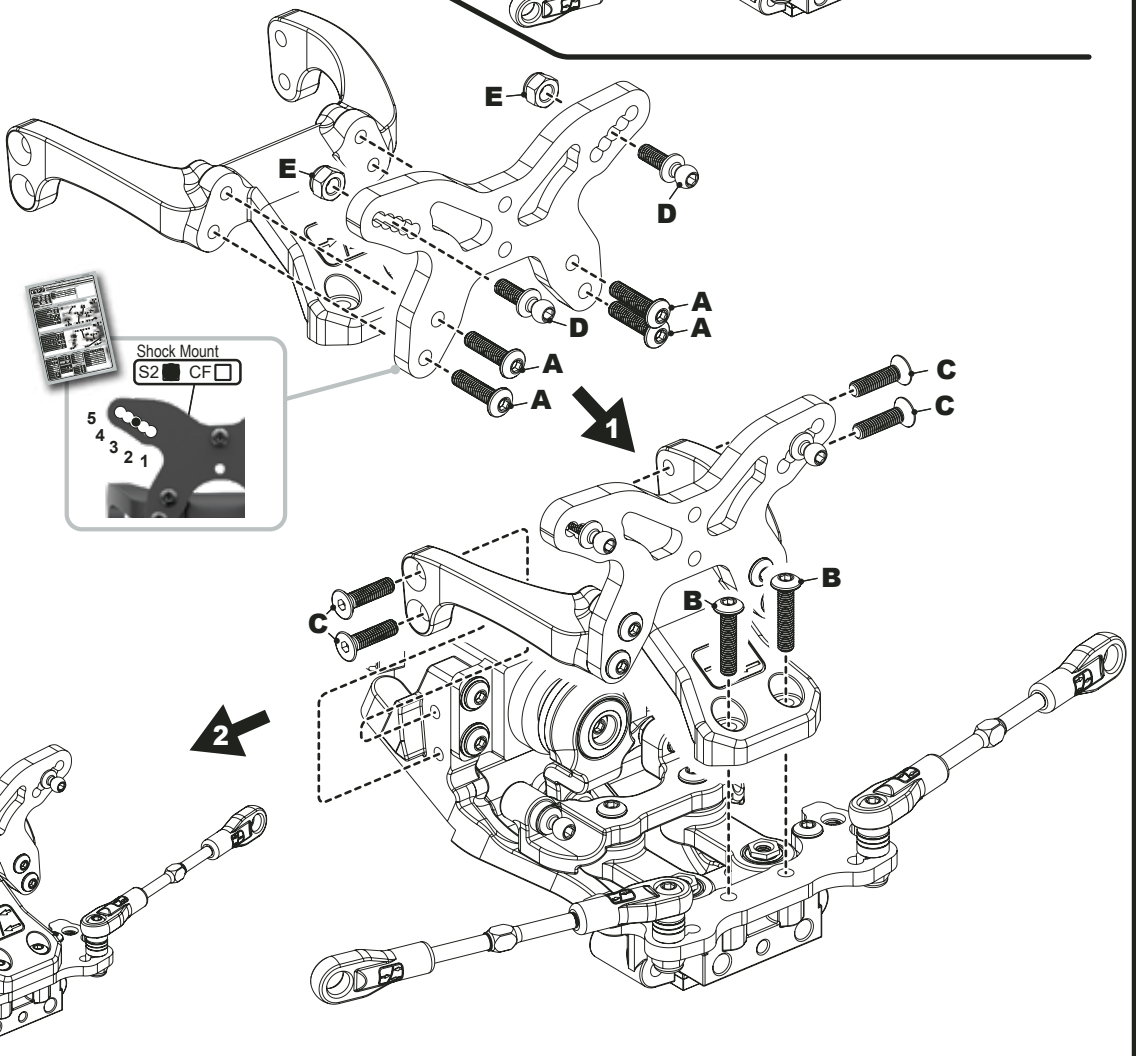

BAG B - Step 16

- A x4**  M3 x 12 Button Hd Screw
- B x2**  M3 x 14 Button Hd Screw
- C x4**  M3 x 12 Csk Hd Screw
- D x2**  Ball Stud Long
- E x2**  M3 Nyloc







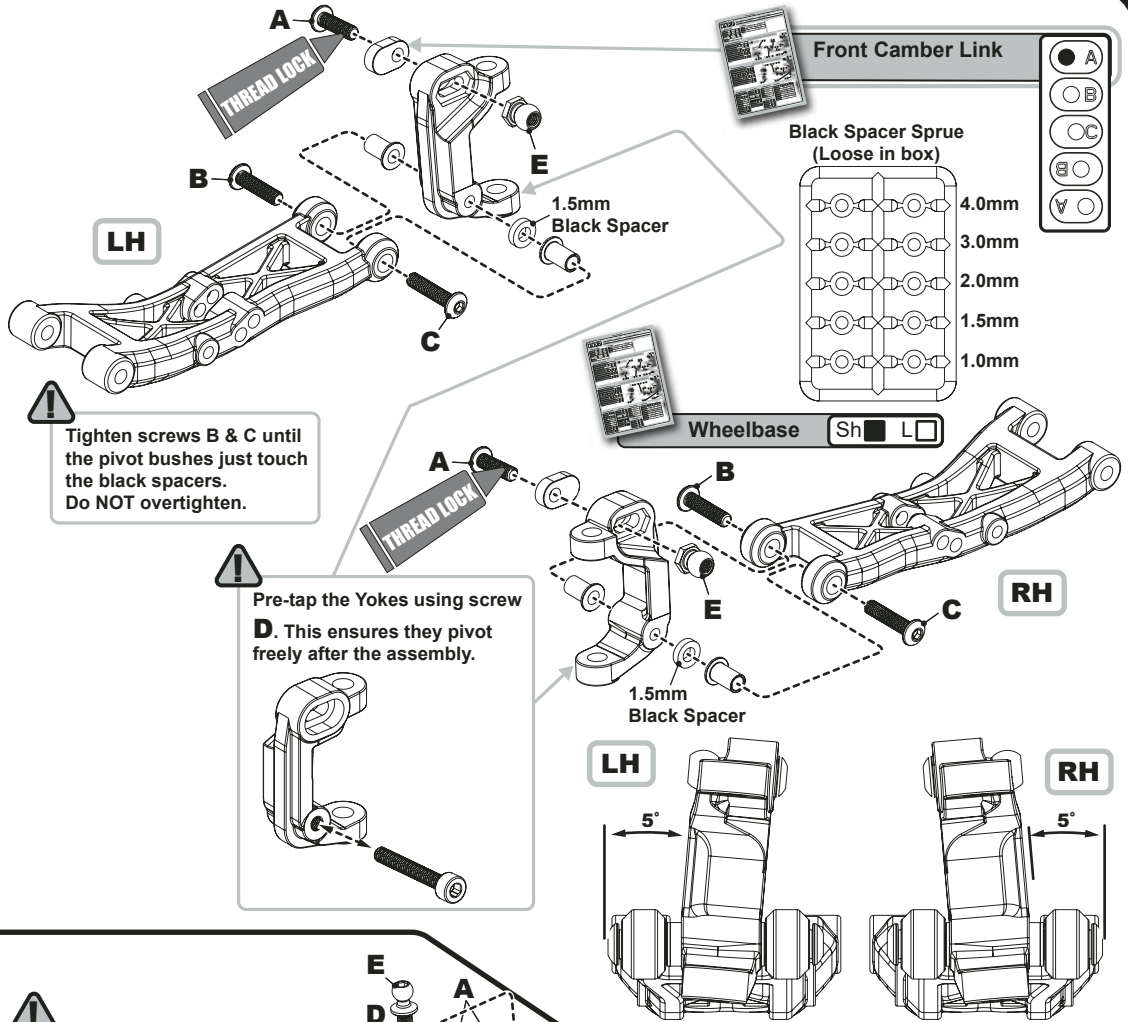

BAG B - Step 17

- A x2**  M3 x 10 Button Hd Screw
- B x2**  M3 x 12 Button Hd Screw
- C x2**  M3 x 14 Button Hd Screw
- D x1**  M3 x 20 Cap Hd Screw
- E x2**  Pivot Ball



BAG B - Step 18



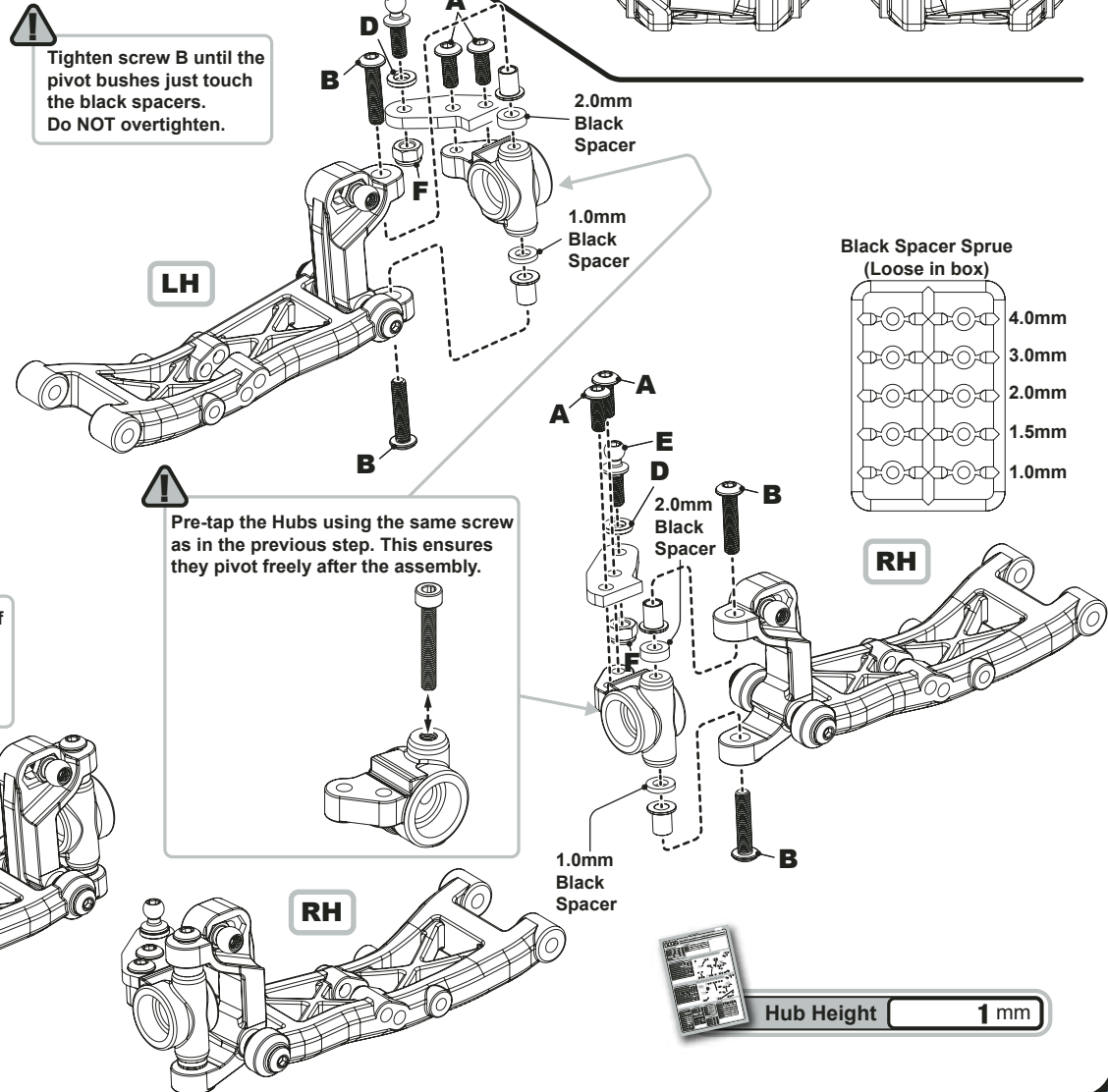

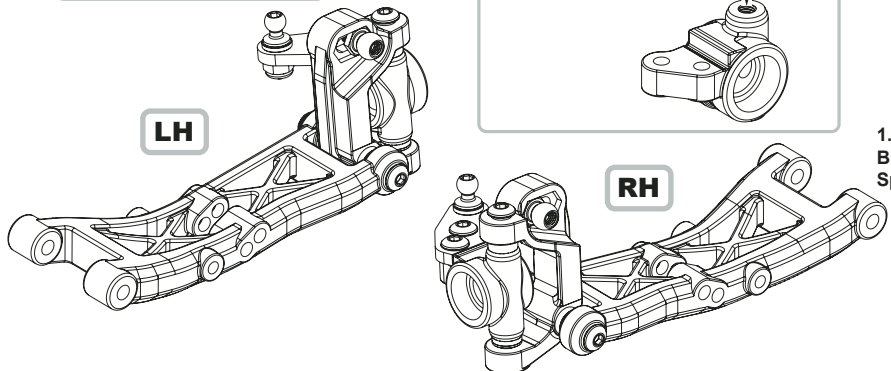

- A x4**  M3 x 8 Button Hd Screw
- B x4**  M3 x 14 Button Hd Screw
- C x2**  M3 x 16 Button Hd Screw
- D x2**  Black Alloy Washer 1.0mm
- E x2**  Ball Stud Long
- F x2**  M3 Nyloc



! Replace screw B with C if you are using a hub height of 3mm or 0mm. Replace the screw that passes through the spacers.





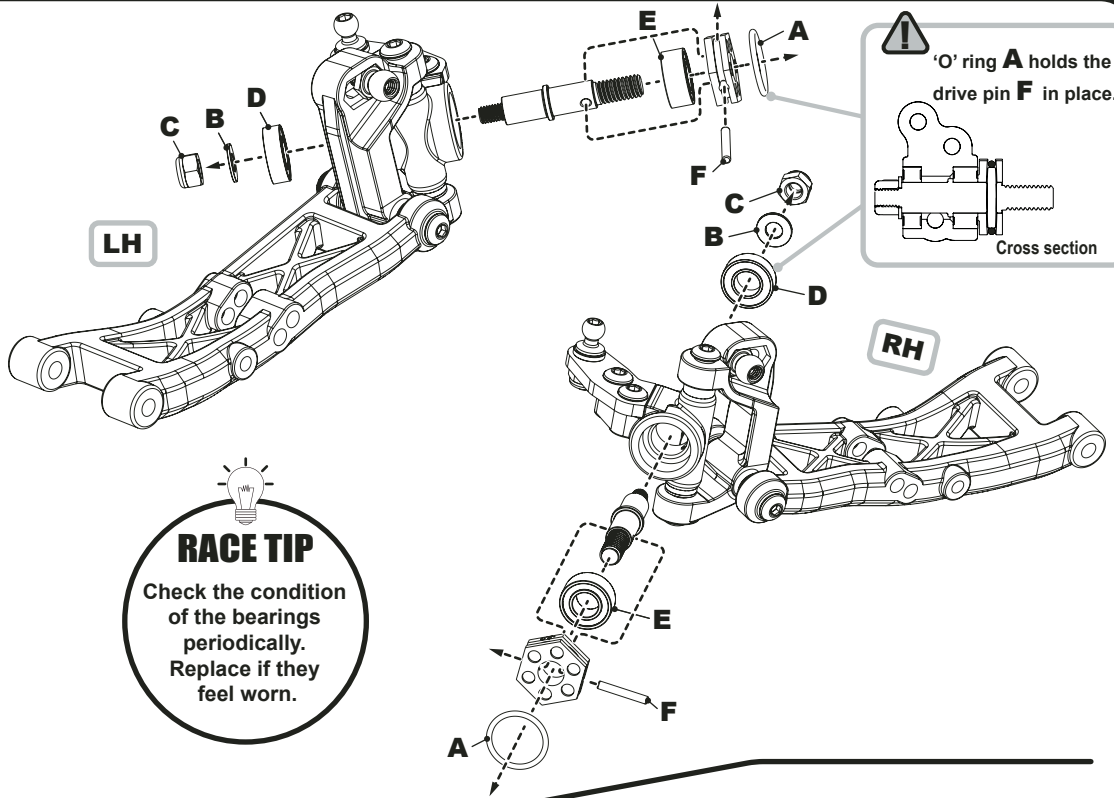

BAG C - Step 19

- A x2**  O'Ring $\varnothing 9 \times 1.0$
- B x2**  M3 Steel Washer
- C x2**  M3 Nyloc Nut
- D x2**  $\varnothing 5 \times \varnothing 10 \times \varnothing 3$ Bearing
- E x2**  $\varnothing 5 \times \varnothing 10 \times \varnothing 4$ Bearing
- F x2**  $\varnothing 1.5 \times 9.8$ Pin

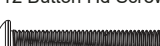

BAG C - Step 20

- A x2**  M3 x 4 Grub Screw
- B x2**  M3 x 12 Button Hd Screw
- C x2**  M3 x 20 Button Hd Screw
- D x1**  M3 Nyloc

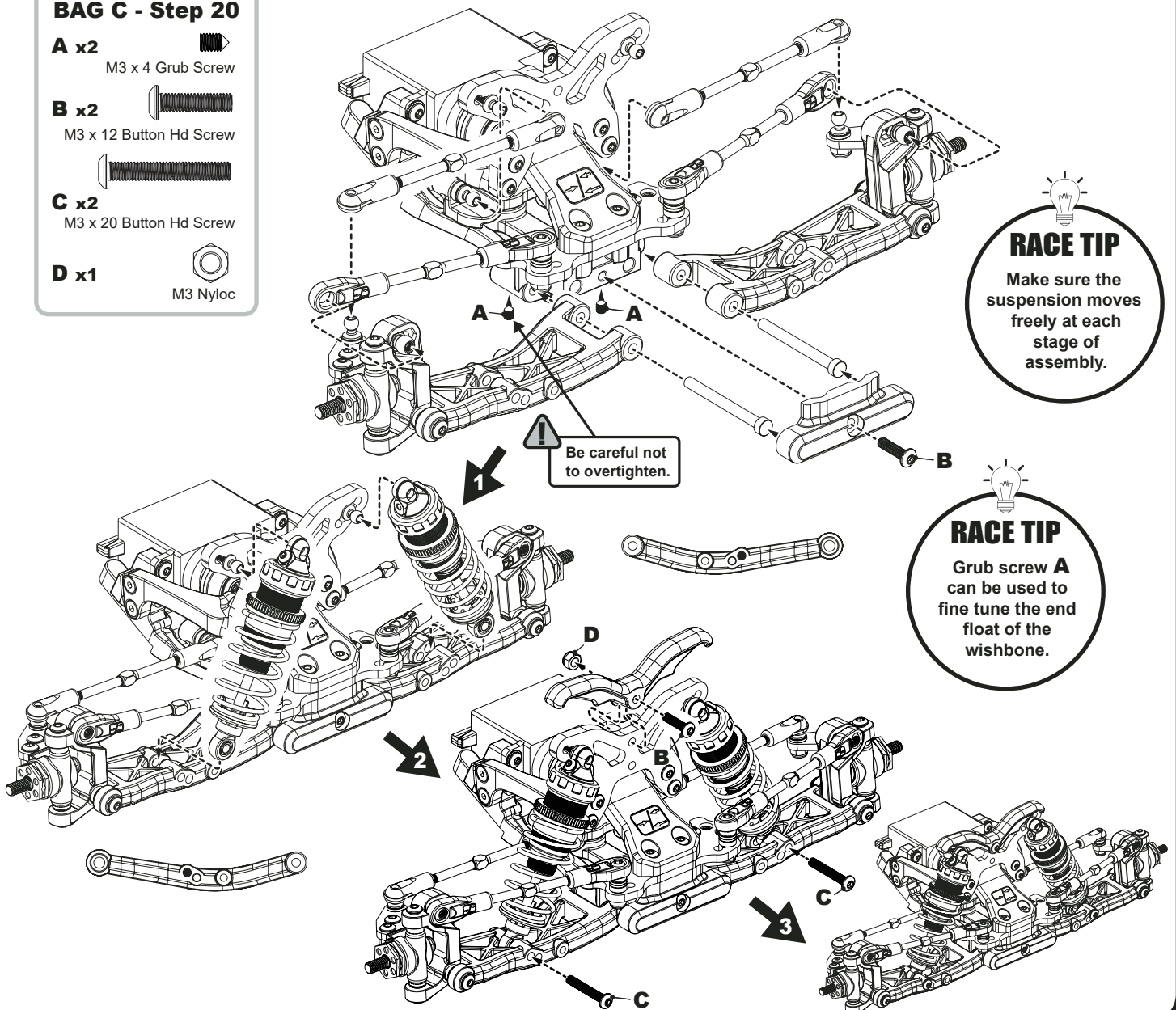

BAG C - Step 21

A x10
M3 x 10 Csk Hd Screw

B x2
M3 x 20 Csk Hd Screw

Assembled as +5mm.

Chassis Insert
0mm +5mm

Chassis Insert.
You can reduce the length of your chassis by 5mm, by using the 0mm chassis insert instead of the 5mm.
See page 26 for setting advice.

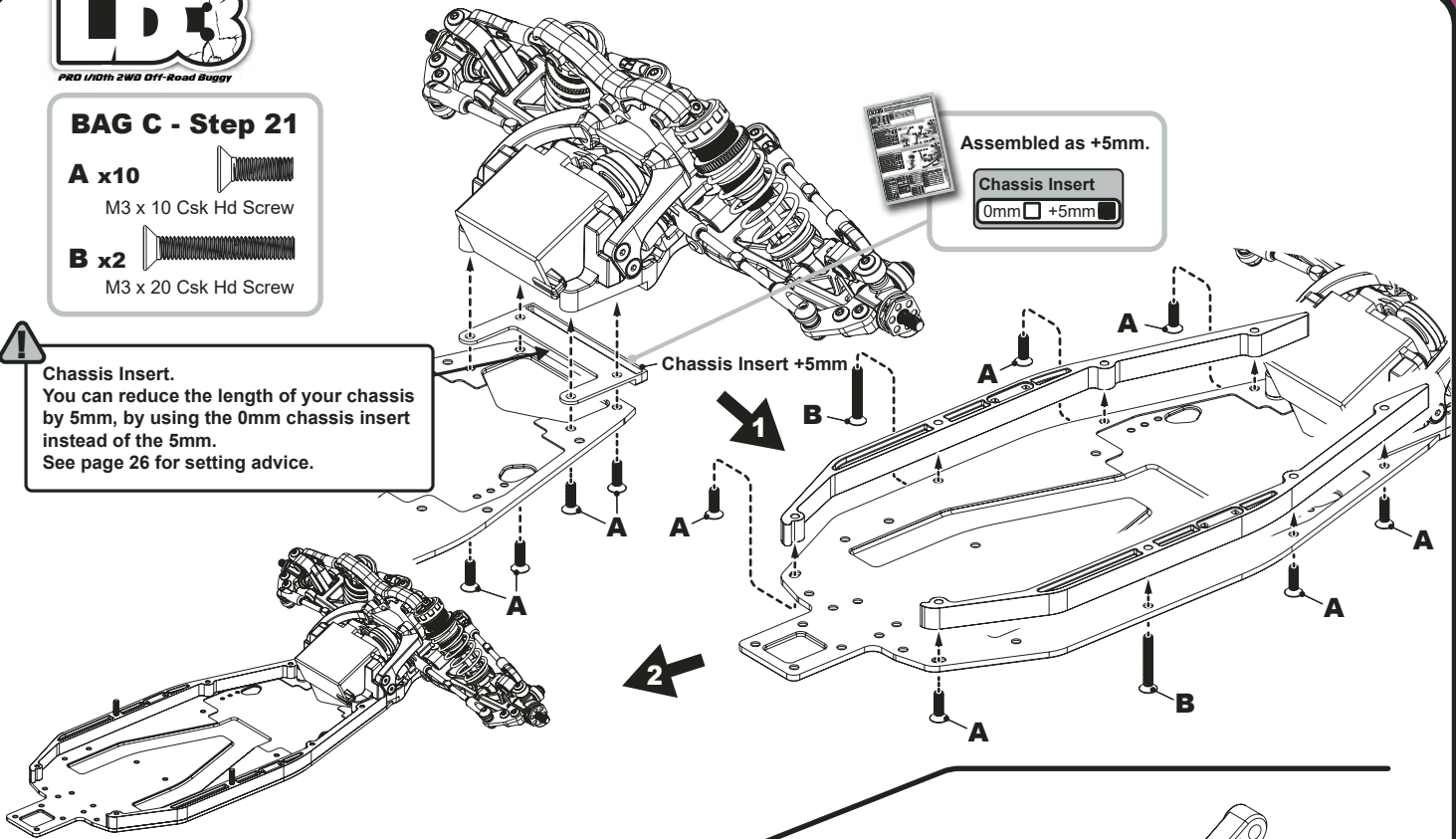

BAG C - Step 22

A x3
ø5 x ø10 x 4 Bearing

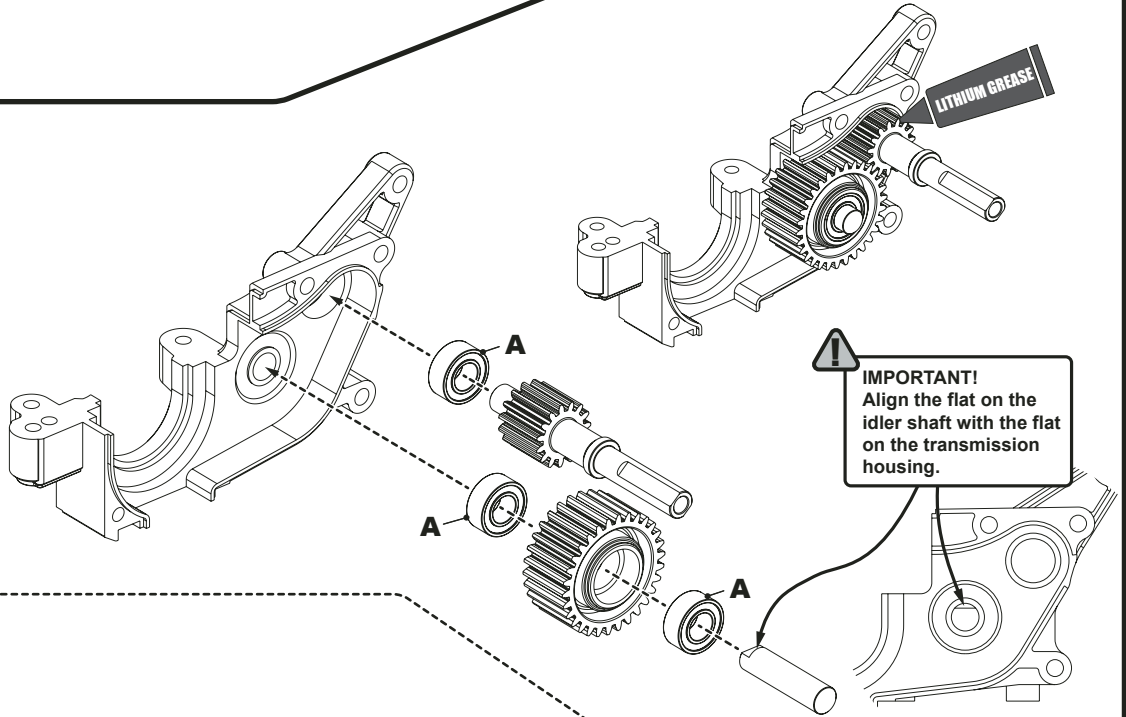

BAG C - Step 22

A x3
ø5 x ø10 x 4 Bearing

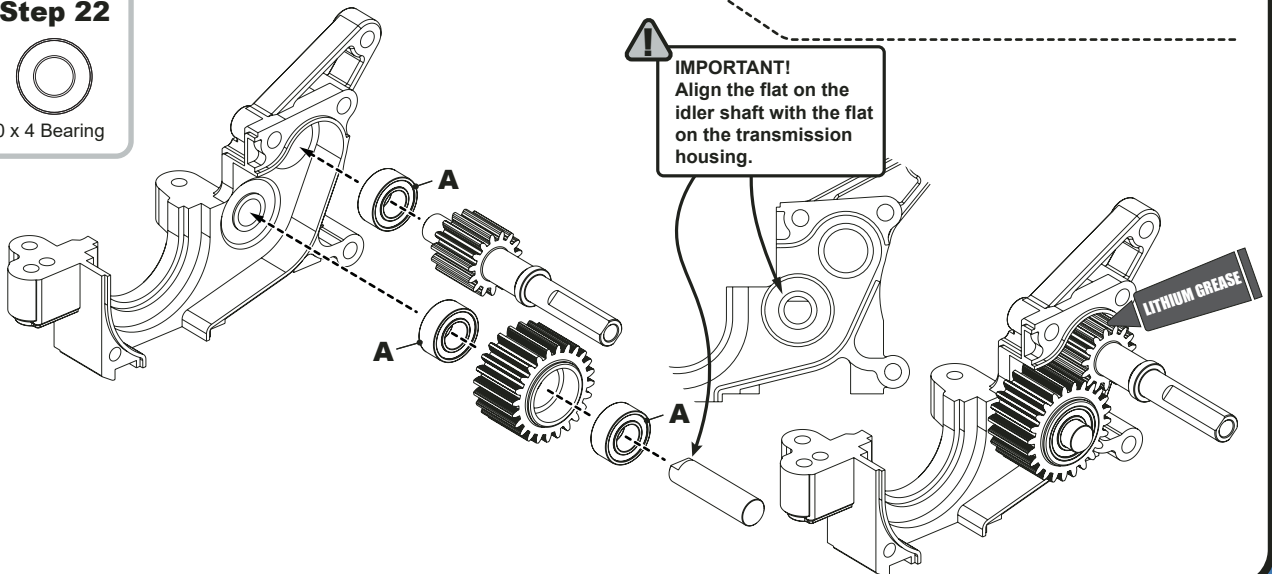

BAG C - Step 22

- A x3**
ø5 x ø10 x 4 Bearing

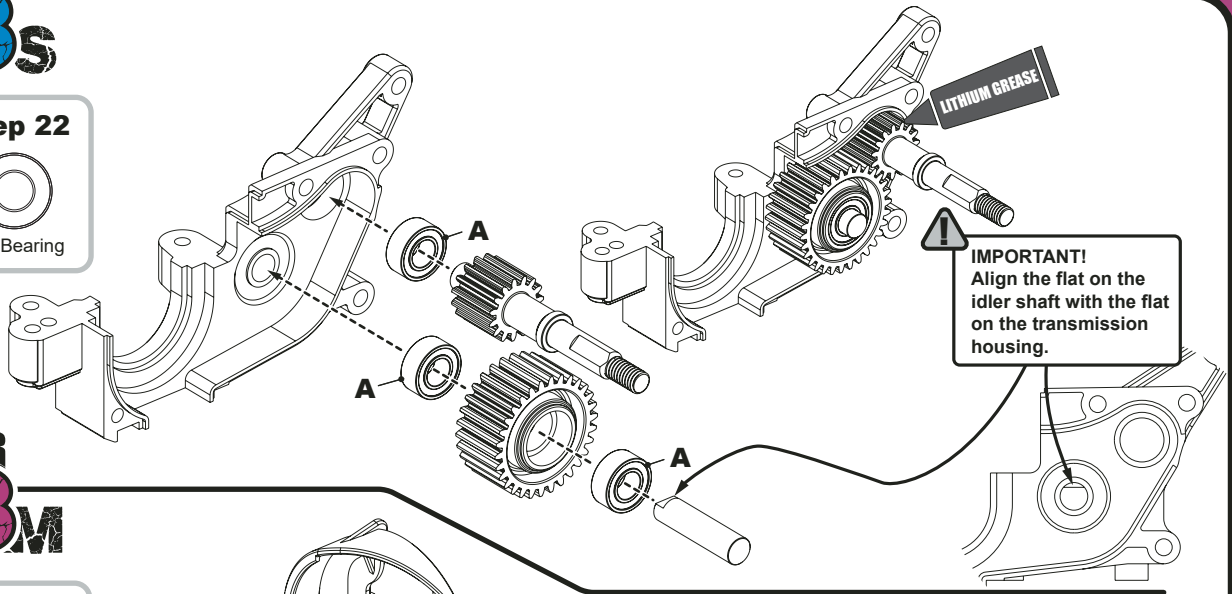

BAG C - Step 23

- A x3**
M3 x 16 Button Hd Screw



- B x3**
M3 x 12 Csk Hd Screw



- C x2**
M2.5 x 8 Csk Hd Screw



- D x1**
M2.5 x 16 Cap Hd Screw

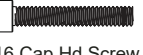

- E x1**
ø5 x ø12 x 4 Bearing

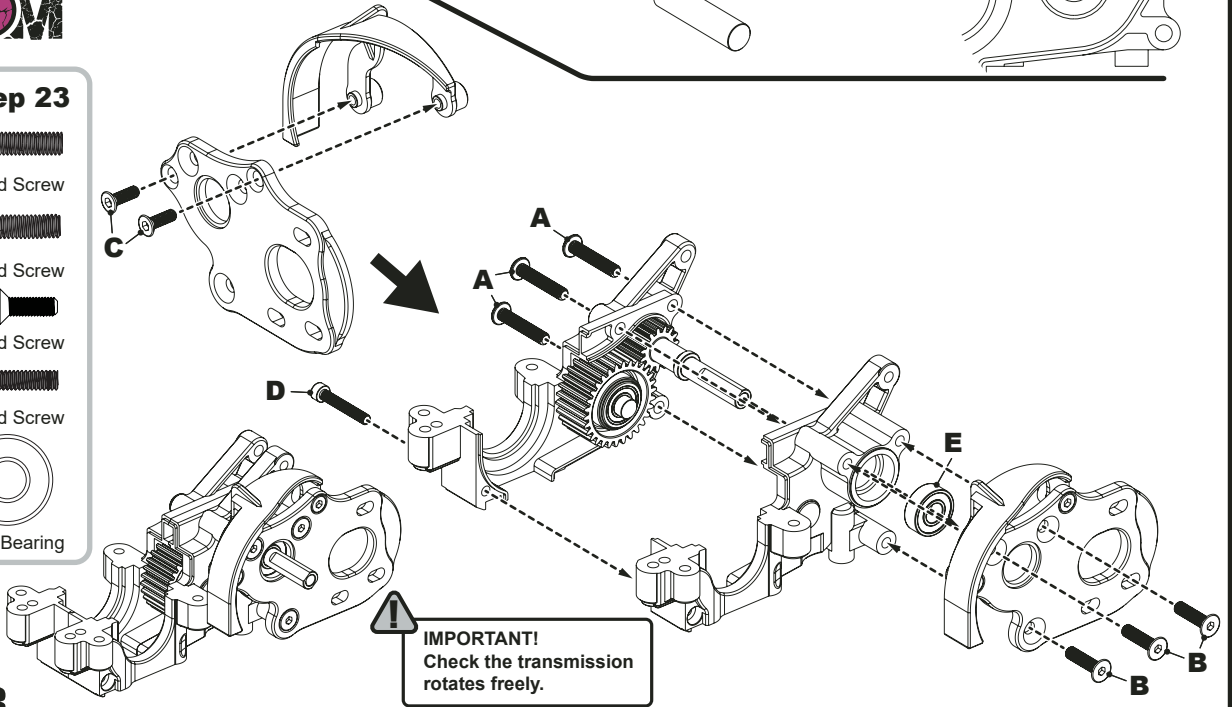

BAG C - Step 23

- A x2**
M3 x 16 Button Hd Screw



- B x3**
M3 x 12 Csk Hd Screw



- C x2**
M2.5 x 8 Csk Hd Screw



- D x1**
M2.5 x 16 Cap Hd Screw



- E x1**
ø5 x ø12 x 4 Bearing



- F x1**
M3 x 20 Button Hd Screw

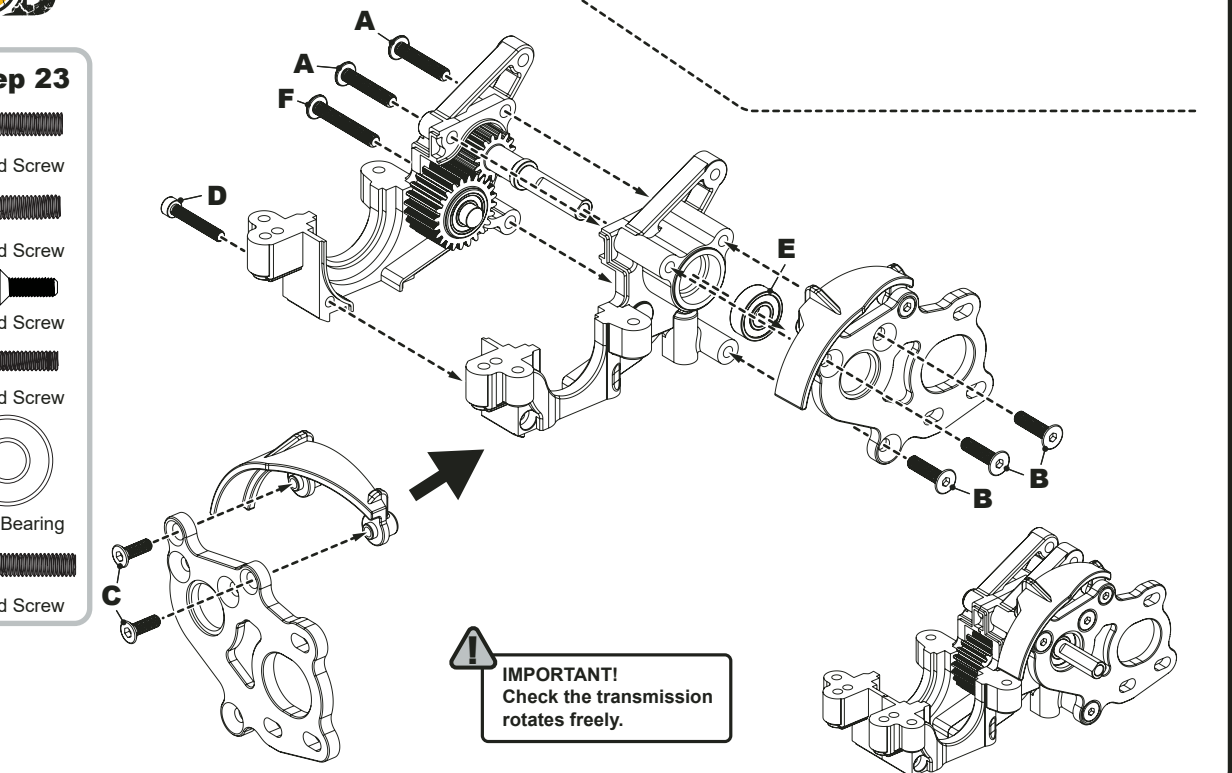

BAG C - Step 23

A x3 
M3 x 16 Button Hd Screw

B x3 
M3 x 12 Csk Hd Screw

C x2 
M2.5x 8 Csk Hd Screw

D x1 
M2.5x 16 Cap Hd Screw

E x1 
ø5 x ø12 x 4 Bearing

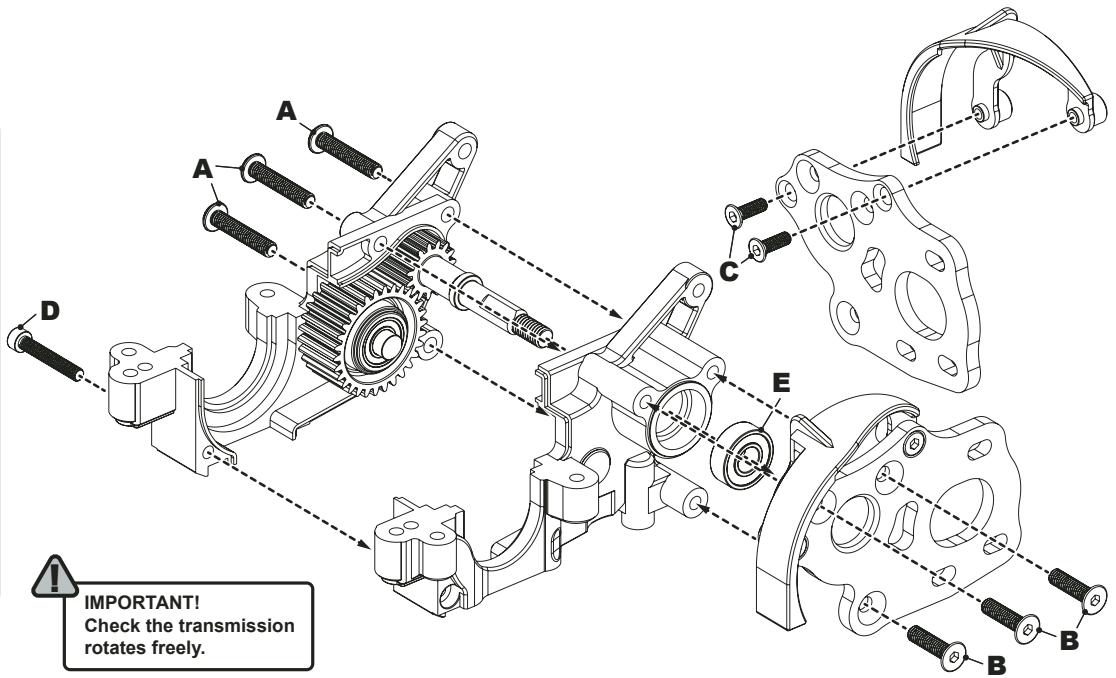

! **IMPORTANT!**
Check the transmission rotates freely.

BAG C - Step 24

A x1 
M3 Nyloc

B x1 
ø5 x ø8 x 2.5 Bearing

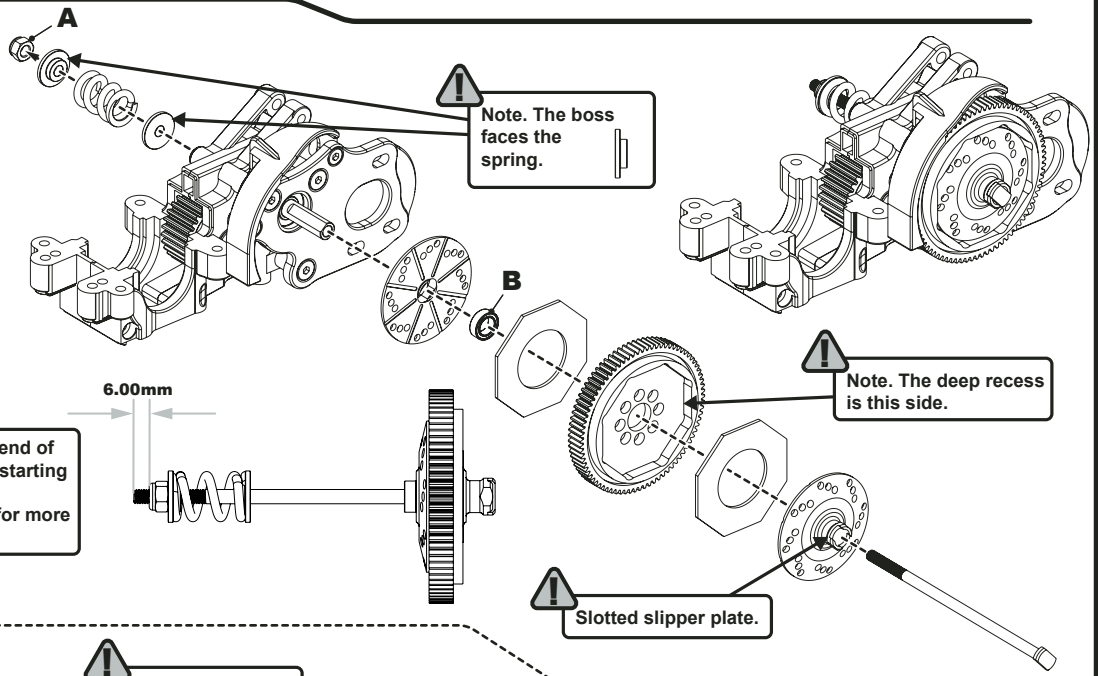

! Note. The boss faces the spring.

! Note. The deep recess is this side.

! Set the nut 6mm from the end of the thread. This is a good starting point for the slipper. Read car settings on P24 for more information.

6.00mm

! Slotted slipper plate.

BAG C - Step 24

A x1 
M3 Nyloc

B x1 
ø5 x ø8 x 2.5 Bearing

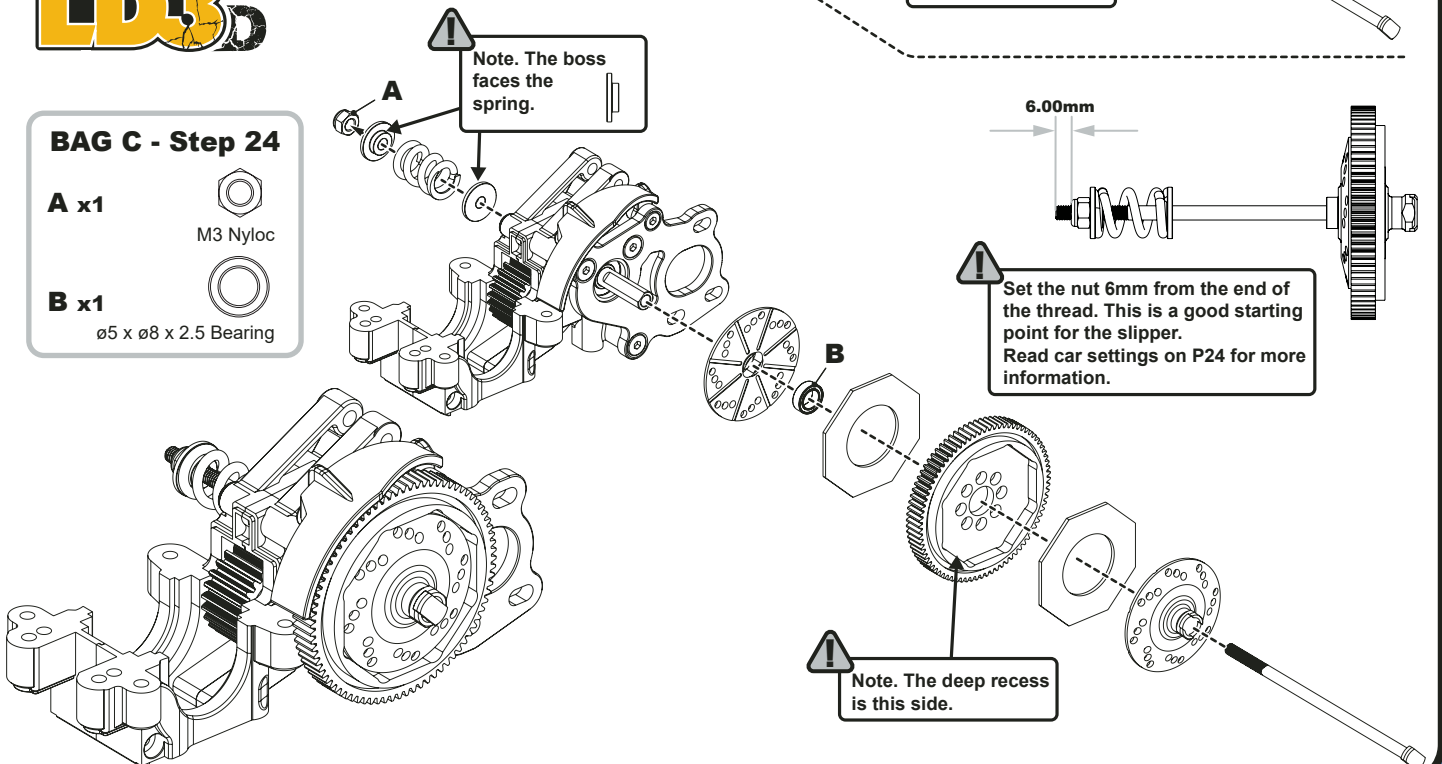

! Note. The boss faces the spring.

! Set the nut 6mm from the end of the thread. This is a good starting point for the slipper. Read car settings on P24 for more information.

6.00mm

! Note. The deep recess is this side.

BAG C - Step 24

A x1

M4 flanged Nyloc

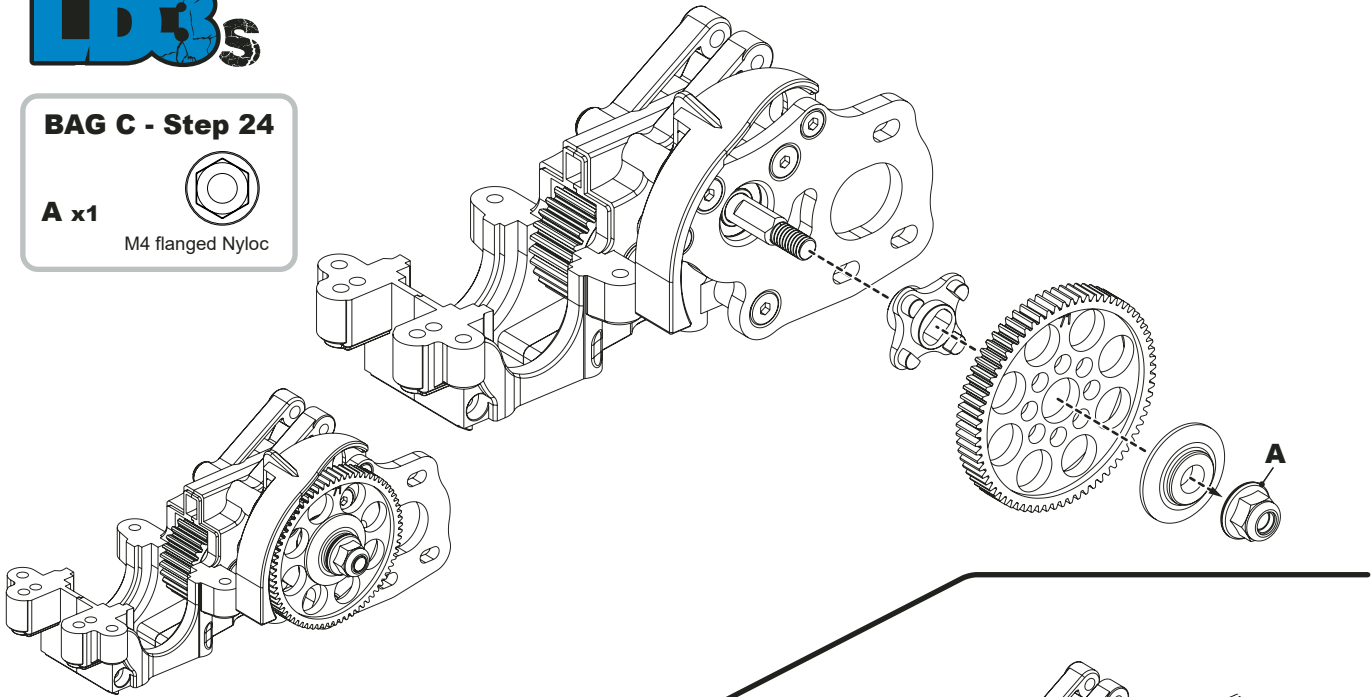

BAG C - Step 25

A x4

M3 x 8 Csk Hd Screw



B x4

M3 x 10 Csk Hd Screw



C x2

M3 x 12 Csk Hd Screw

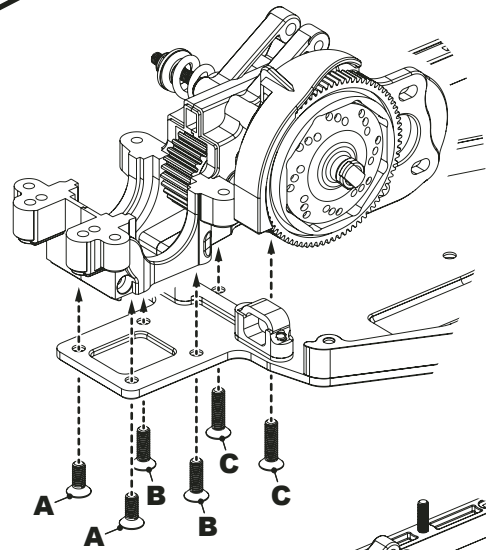
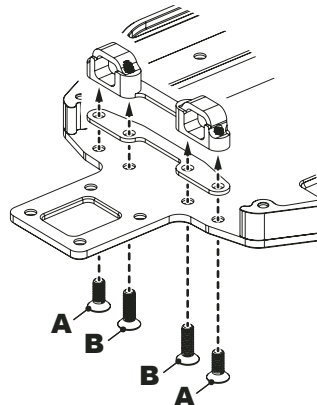

BAG C - Step 25

A x2

M3 x 8 Csk Hd Screw



B x4

M3 x 10 Csk Hd Screw



C x2

M3 x 12 Csk Hd Screw

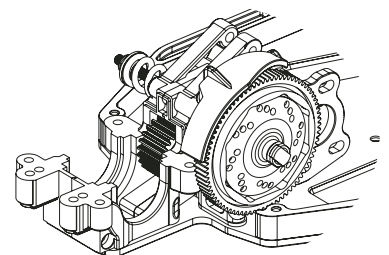
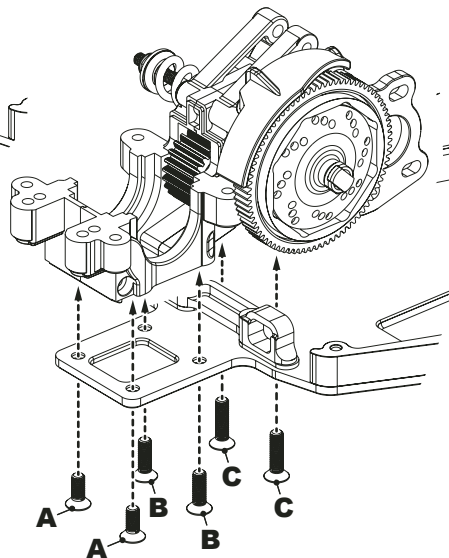
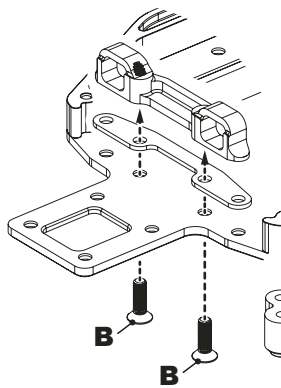

BAG C - Step 26

A x2 
M3 x 12 Button Hd Screw

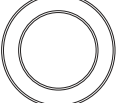
B x2 
ø10 x ø15 x 4 bearing

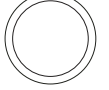
C x4 
ø10 x ø12 x 0.20 Shim

Ensure you use a matching pair of eccentrics. The kit contains both HIGH/LOW and MID eccentrics. Base setting is LOW at this stage.

COUGAR LD3
Fit the ball diff instead of the gear diff pictured.

Start with 2 shims either side, and then, if necessary, remove to achieve a small amount of end float.

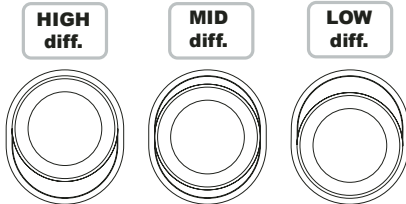
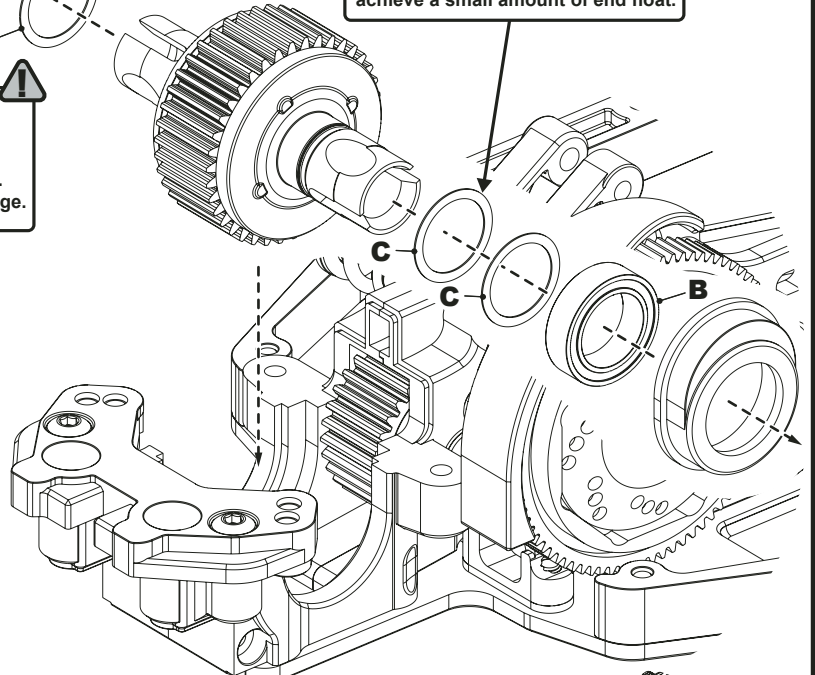
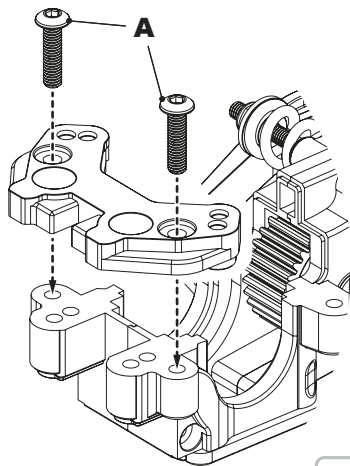

RACE TIP
Periodically check the gears for signs of damage or wear. Do not run them dry. Reapply grease every 10-12 runs.

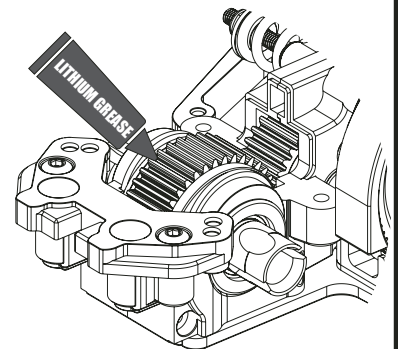

BAG C - Step 27

A x2 
M3 x 12 Button Hd Screw

B x2 
M3 x 16 Csk Hd Screw

C x2 
M3 Washer

D x4 
M3 Nyloc

E x2 
Ball Stud Long

Leave loose until page 22 step 36

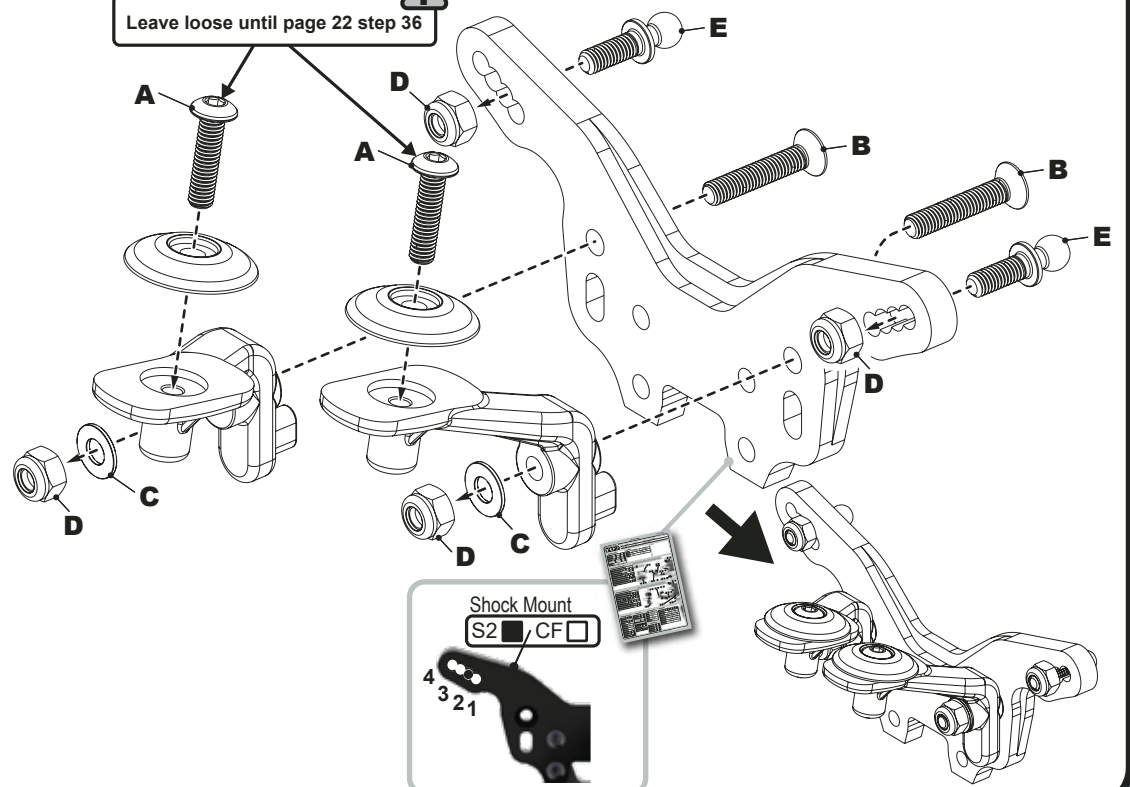

BAG D - Step 28

A x4 
M3 x 12 Button Hd Screw

B x2 
M3 x 14 Button Hd Screw

C x2 
M3 x 20 Button Hd Screw

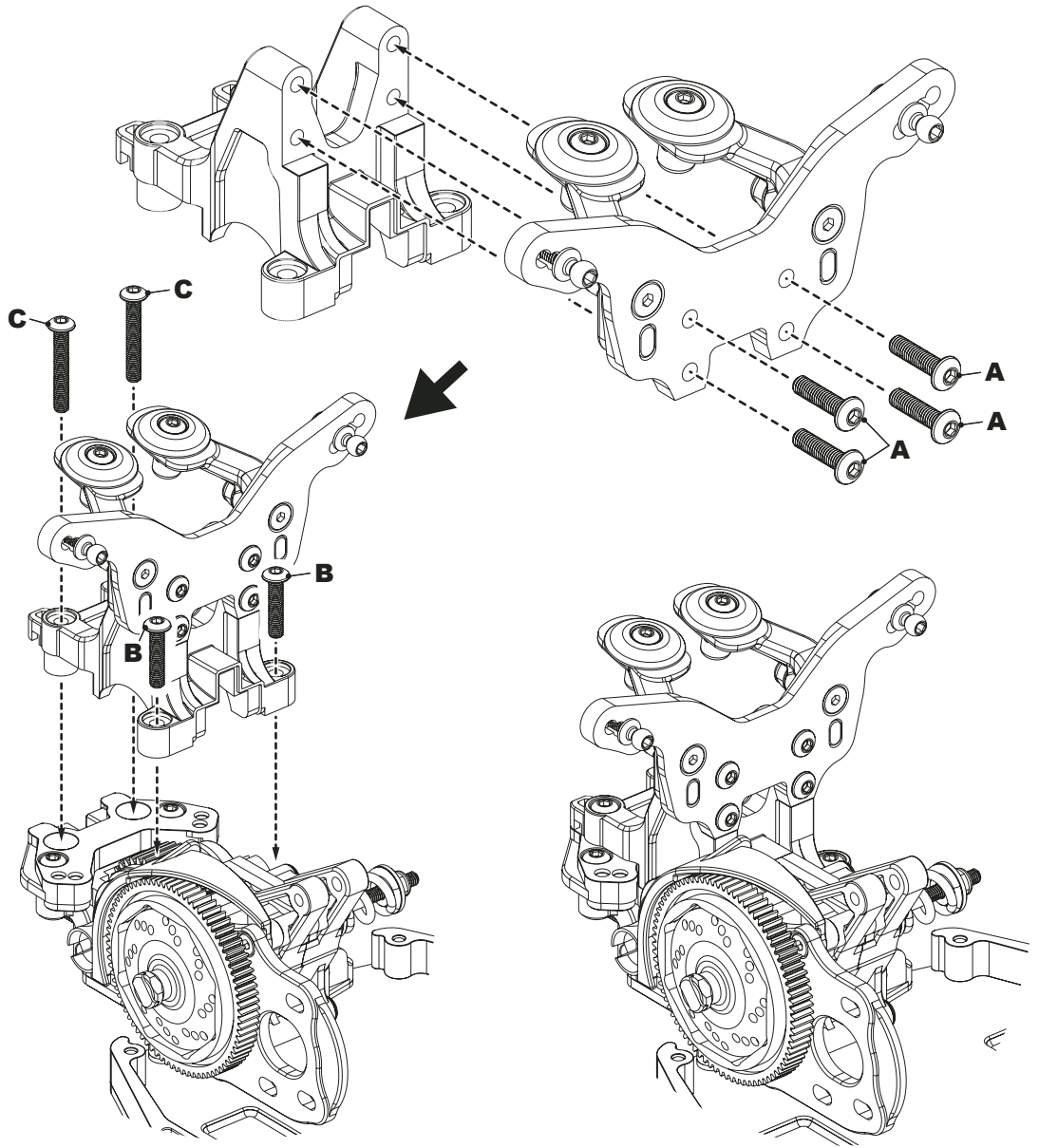

BAG D - Step 29

A x2 
M2.5 x 6 Button Hd Screw

B x2 
Ball Stud Short

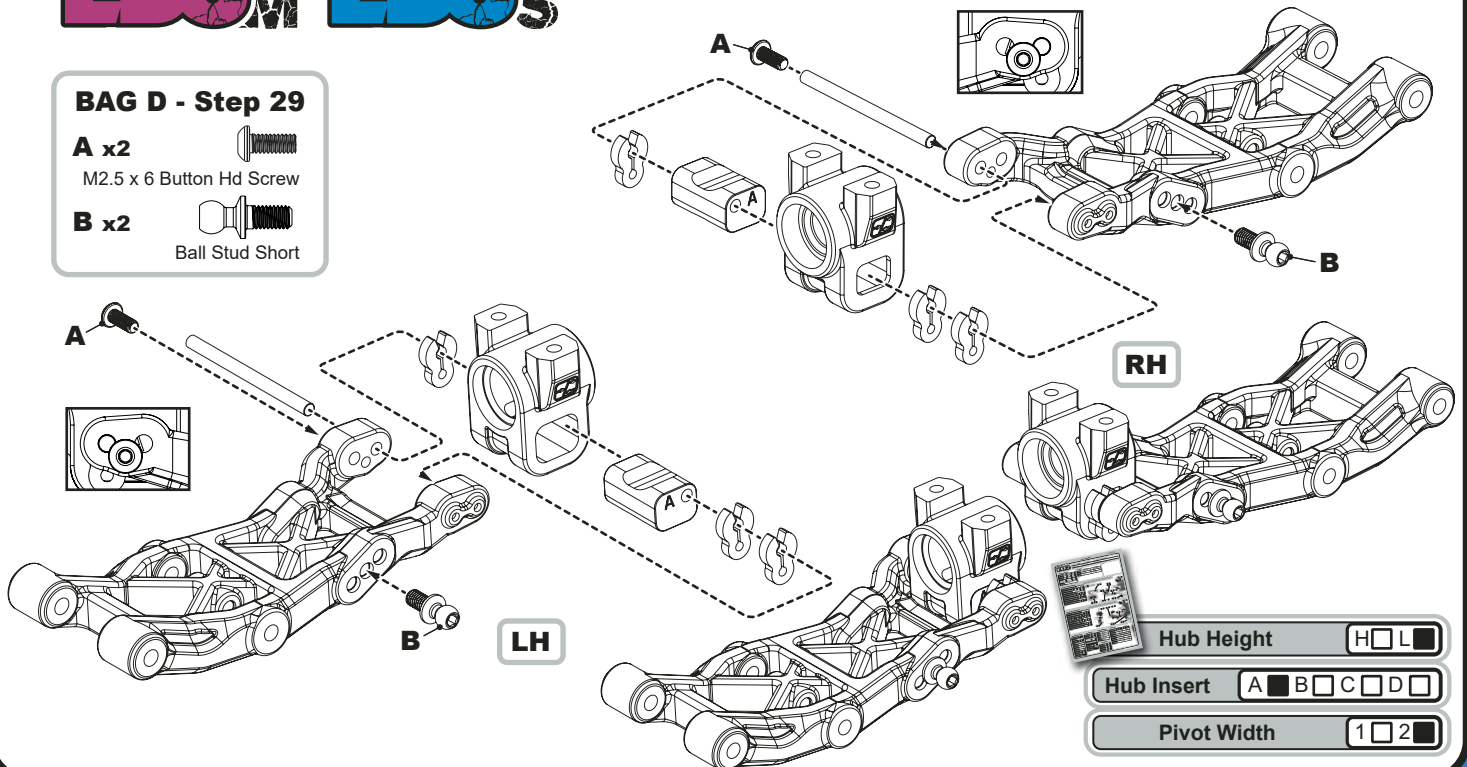



Hub Height H L

Hub Insert A B C D



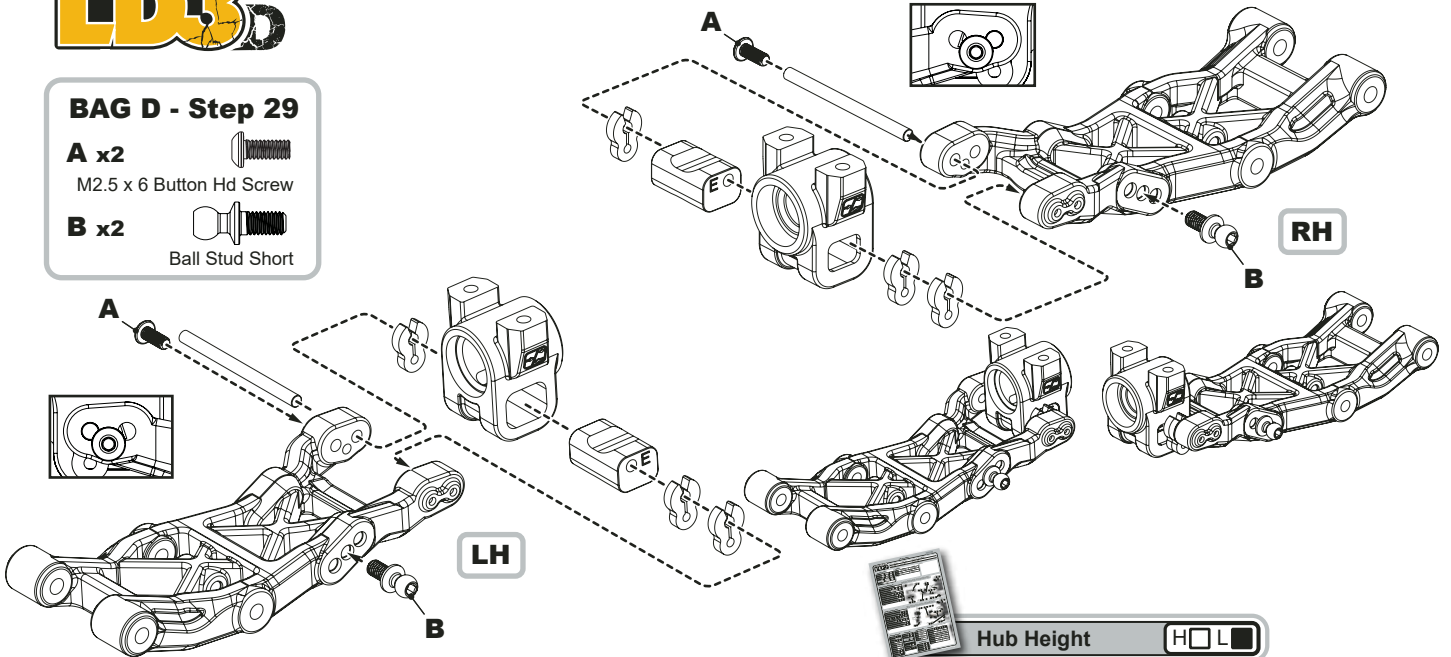

Pivot Width 1 2

BAG D - Step 29

- A x2**  M2.5 x 6 Button Hd Screw
- B x2**  Ball Stud Short



BAG D - Step 30



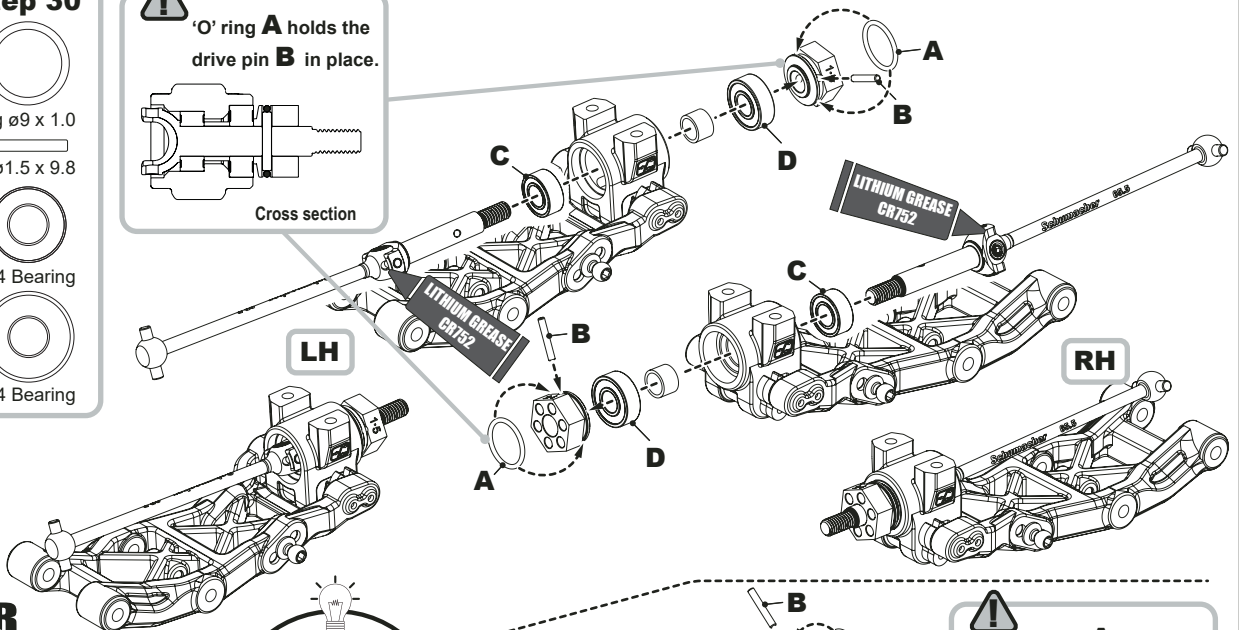
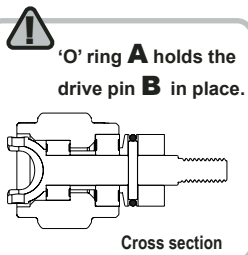

- A x2**  O'Ring ø9 x 1.0
- B x2**  ø1.5 x 9.8
- C x2**  ø5 x ø10 x 4 Bearing
- D x2**  ø5 x ø12 x 4 Bearing

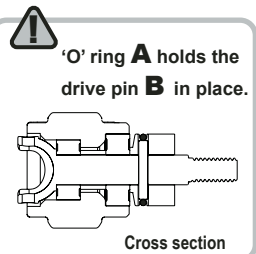

RACE TIP
Grease the CVD before use, keep it clean and make sure the grub screw is tight.



BAG D - Step 30

- A x2**  O'Ring ø9 x 1.0
- B x2**  ø1.5 x 9.8
- C x2**  ø5 x ø10 x 4 Bearing
- D x2**  ø5 x ø12 x 4 Bearing

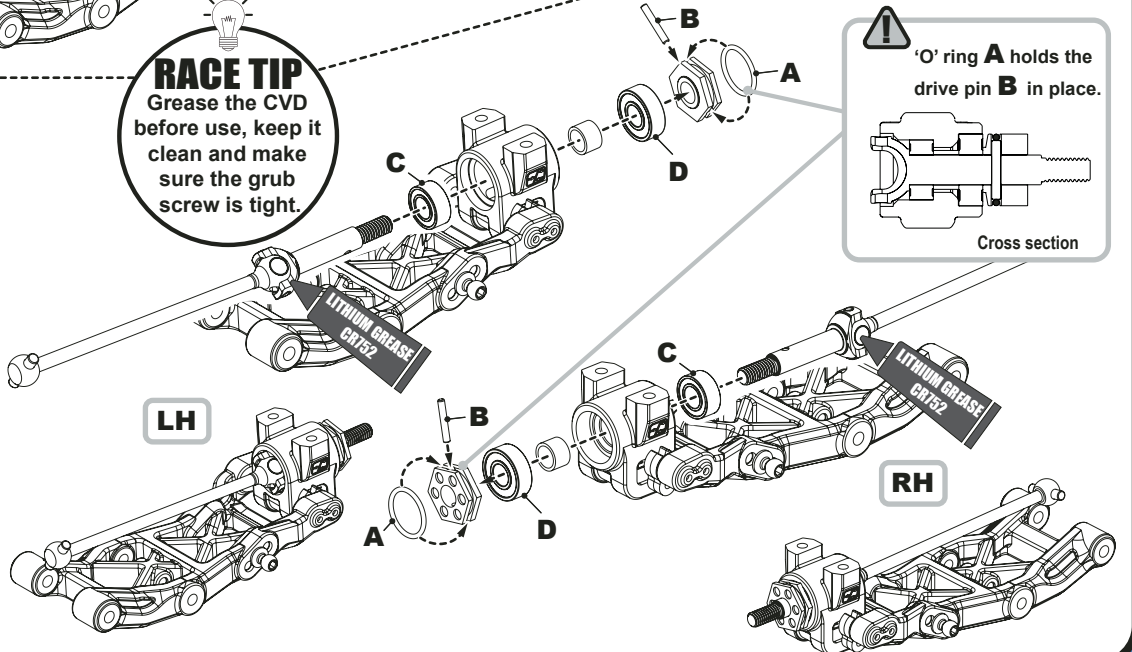

BAG D - Step 31

A x4
M3 x 10 Button Hd Screw

B x2
Black 3.0mm Washer

C x2
Ball Stud Long

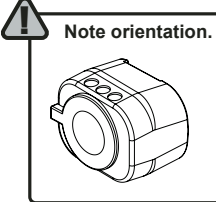
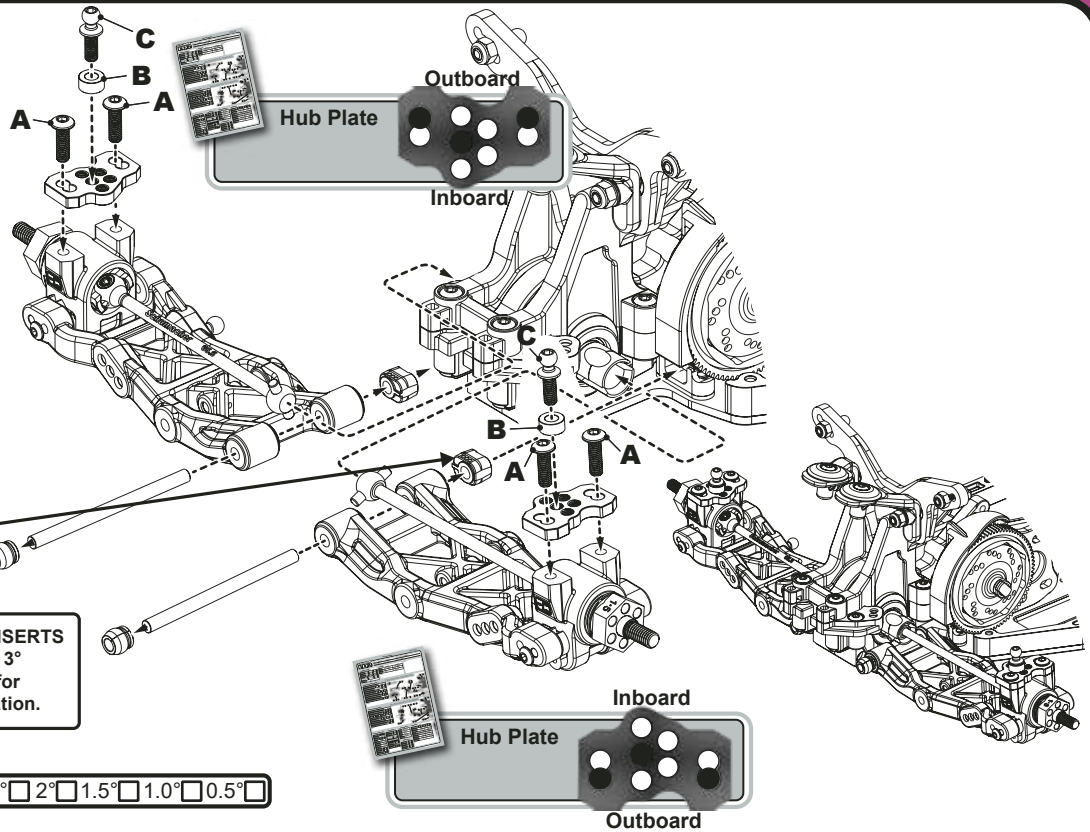

REAR TOE INSERTS
3 Dot block = 3°
See page 32 for more information.

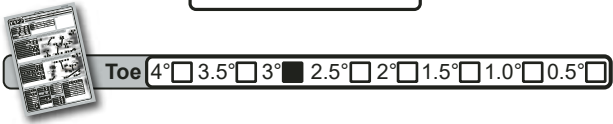

BAG D - Step 32

A x2
M3 x 16 Button Hd Screw

B x2
Black 0.5mm Washer

C x4
Black 1.0mm Washer

D x2
Ball Stud Extra Long

Strap spacers are for fine tuning the car for different tracks. The number on the spacer gives the amount of anti-squat in degrees. 1° is the base setting.



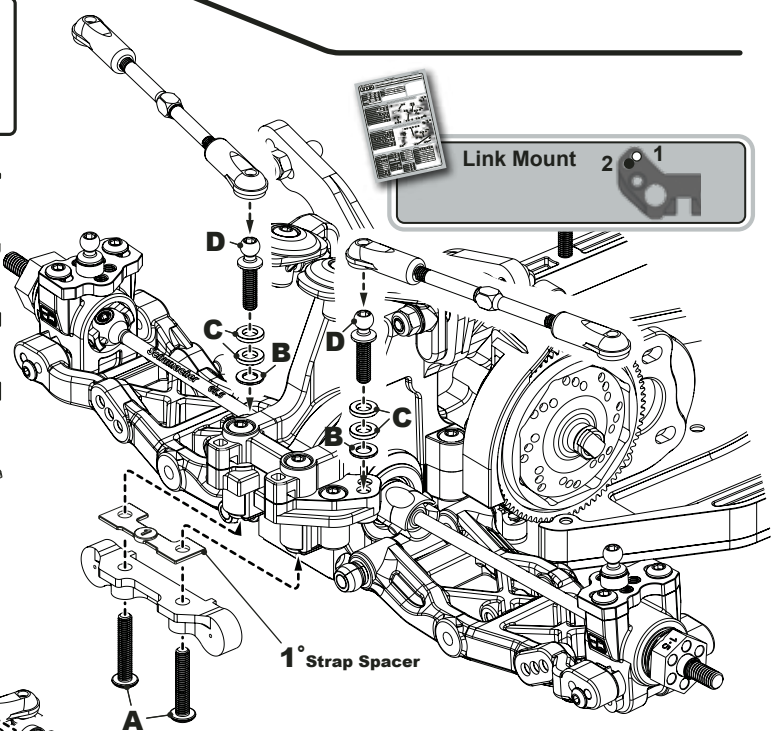

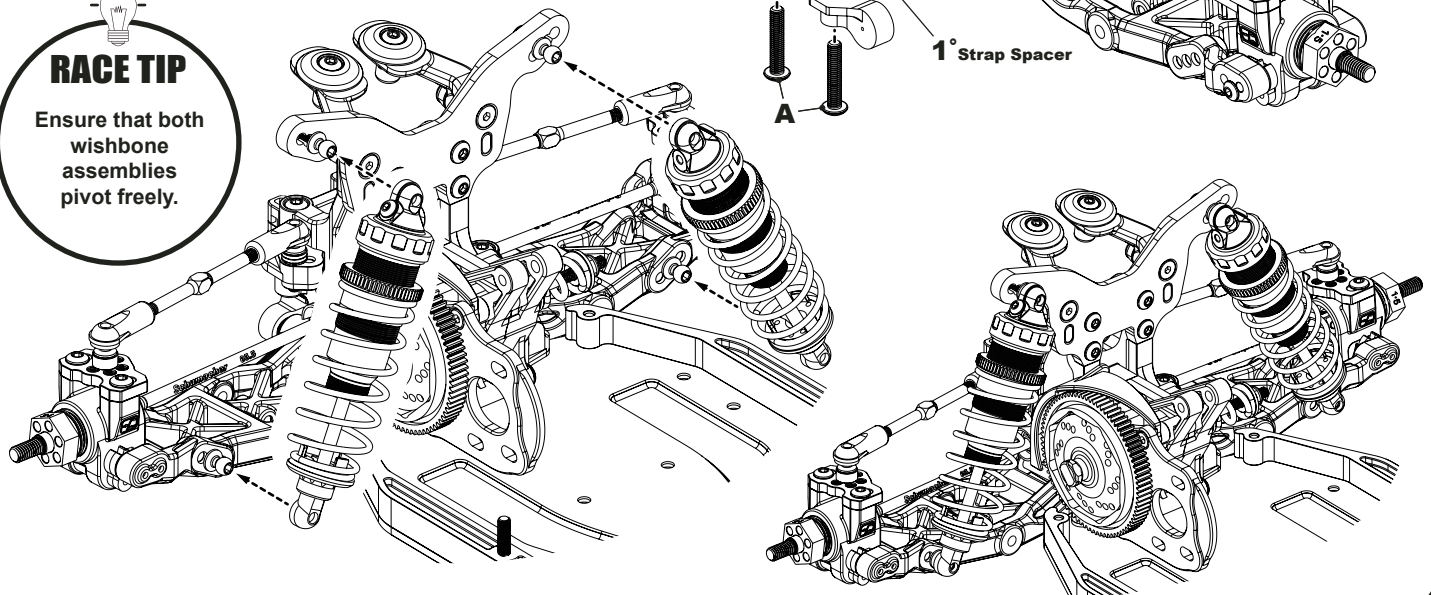

This spacer is only used when running the low pivot pin. Remove the spacer under the front strap (Page 16 Bag C Step 25) and fit this under the rear strap spacers.



RACE TIP
Ensure that both wishbone assemblies pivot freely.



BAG D - Step 33

- A x2**  M2.5 x 6 Csk Hd Screw
- B x1**  M3 x 6 Csk Hd Screw
- C x3**  M3 x 8 Cap Hd Screw
- D x1**  M3 x 4 Grub Screw
- E x3**  M3 Washer
- F x2**  M2.5 Thread Insert

Pinion
Not Included

Power Capacitor
Not Included

Speed Controller
Not Included

Receiver
Not Included

Transponder
Not Included

Servo Tape

Radio Tray 1 2 3

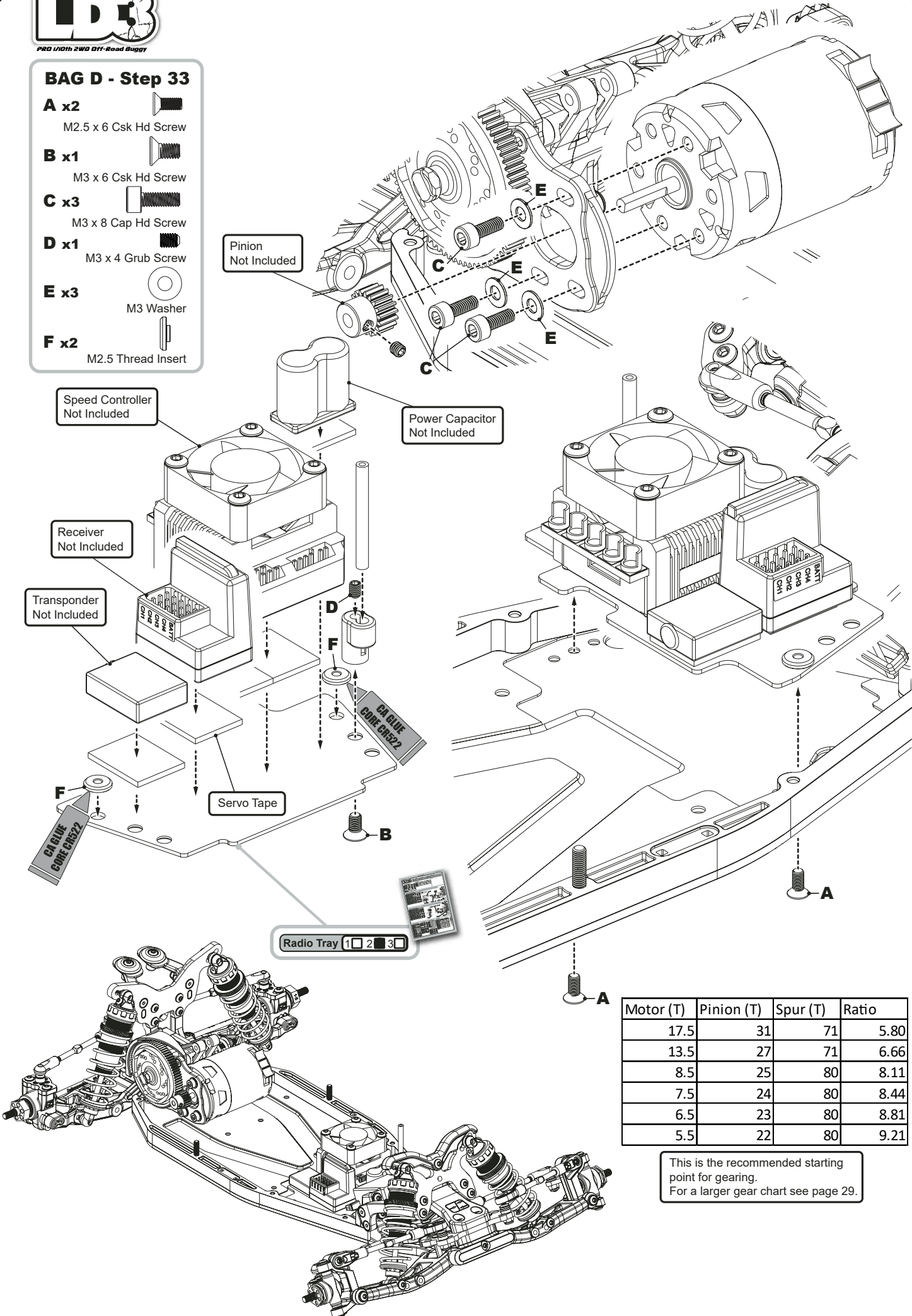

Motor (T)	Pinion (T)	Spur (T)	Ratio
17.5	31	71	5.80
13.5	27	71	6.66
8.5	25	80	8.11
7.5	24	80	8.44
6.5	23	80	8.81
5.5	22	80	9.21

This is the recommended starting point for gearing.
For a larger gear chart see page 29.

! Three LiPo spacers are included in the kit. To be used with different height lipos.

- ULCG LiPo's use the 1.5mm spacer.
- LCG LiPo's use the 3.5mm spacer.
- Full height LiPo's use the 6.5mm spacer.

BAG D - Step 34

A x4  M3 x 14 Button Hd Screw

B x4  M3 x 16 Button Hd Screw

C x4  M3 x 20 Button Hd Screw

D x6  M3 Washer

E x2  M3 Nyloc

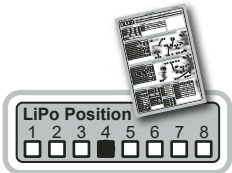
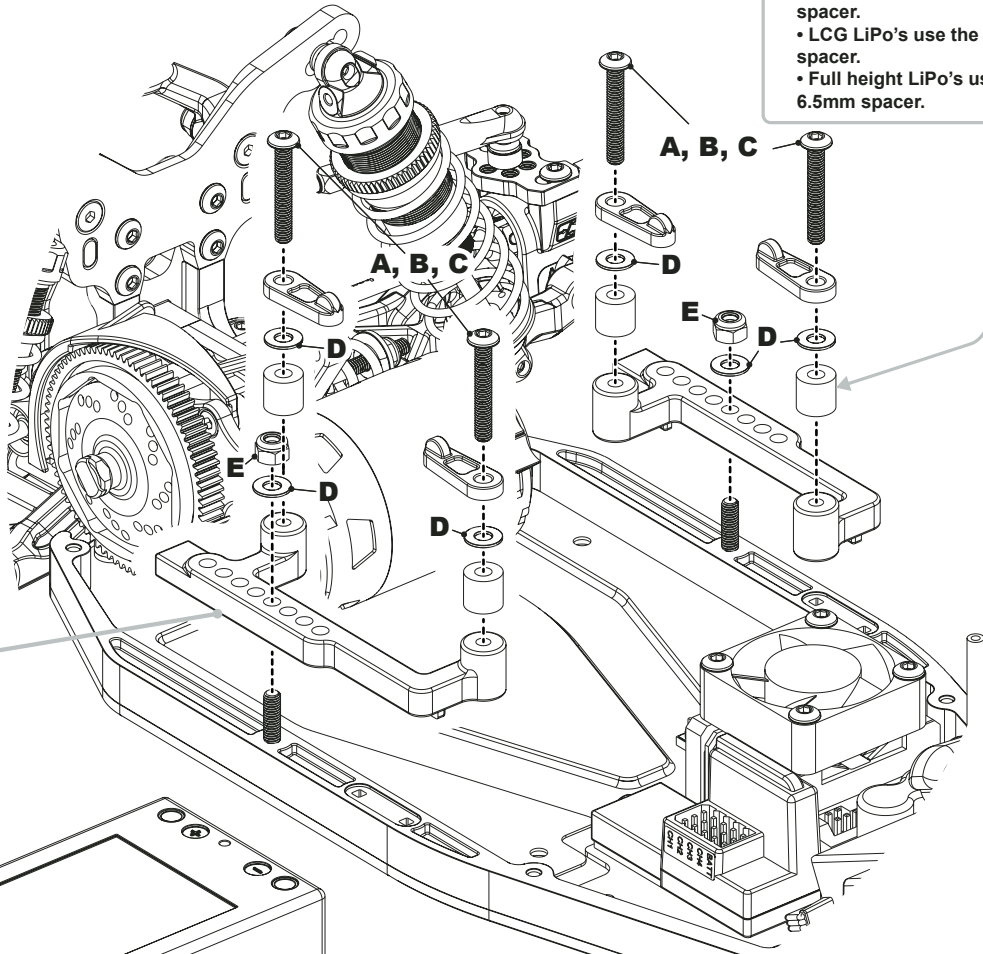

! LIPO POSITIONS
See page 27 for more information.

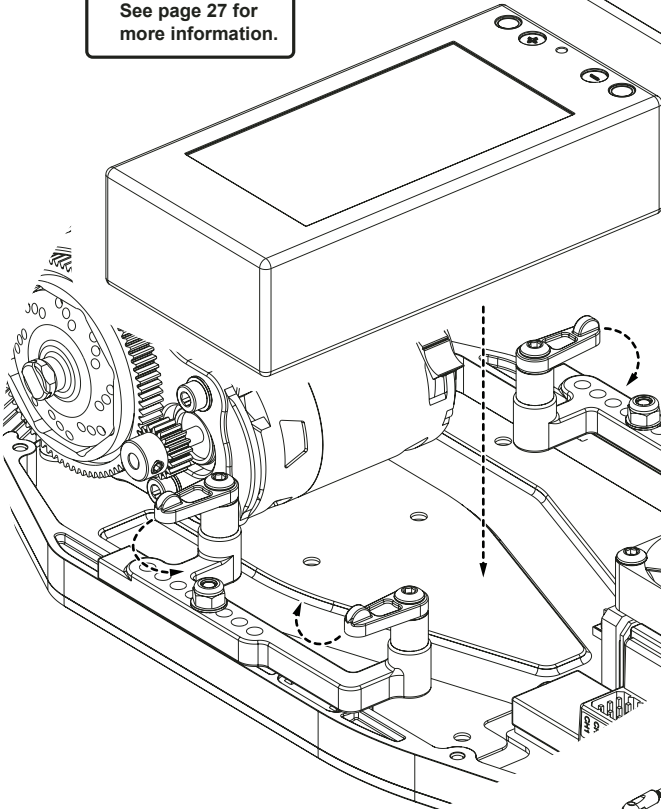

A	B	C
1.5mm ULCG Use 14mm screw.	3.5mm LCG Use 16mm screw.	6.5mm Full Height Use 20mm screw.

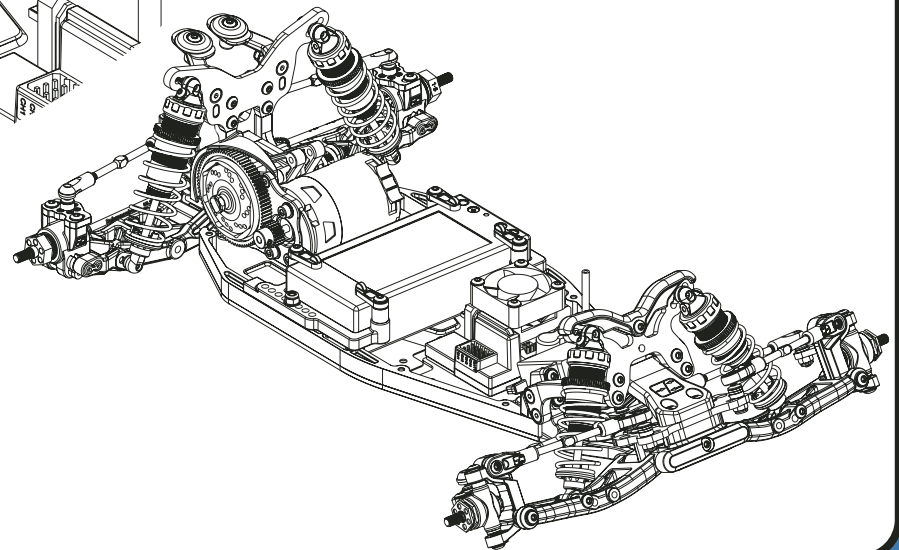

BAG D - Step 35

A x4



M4 Serrated Nut

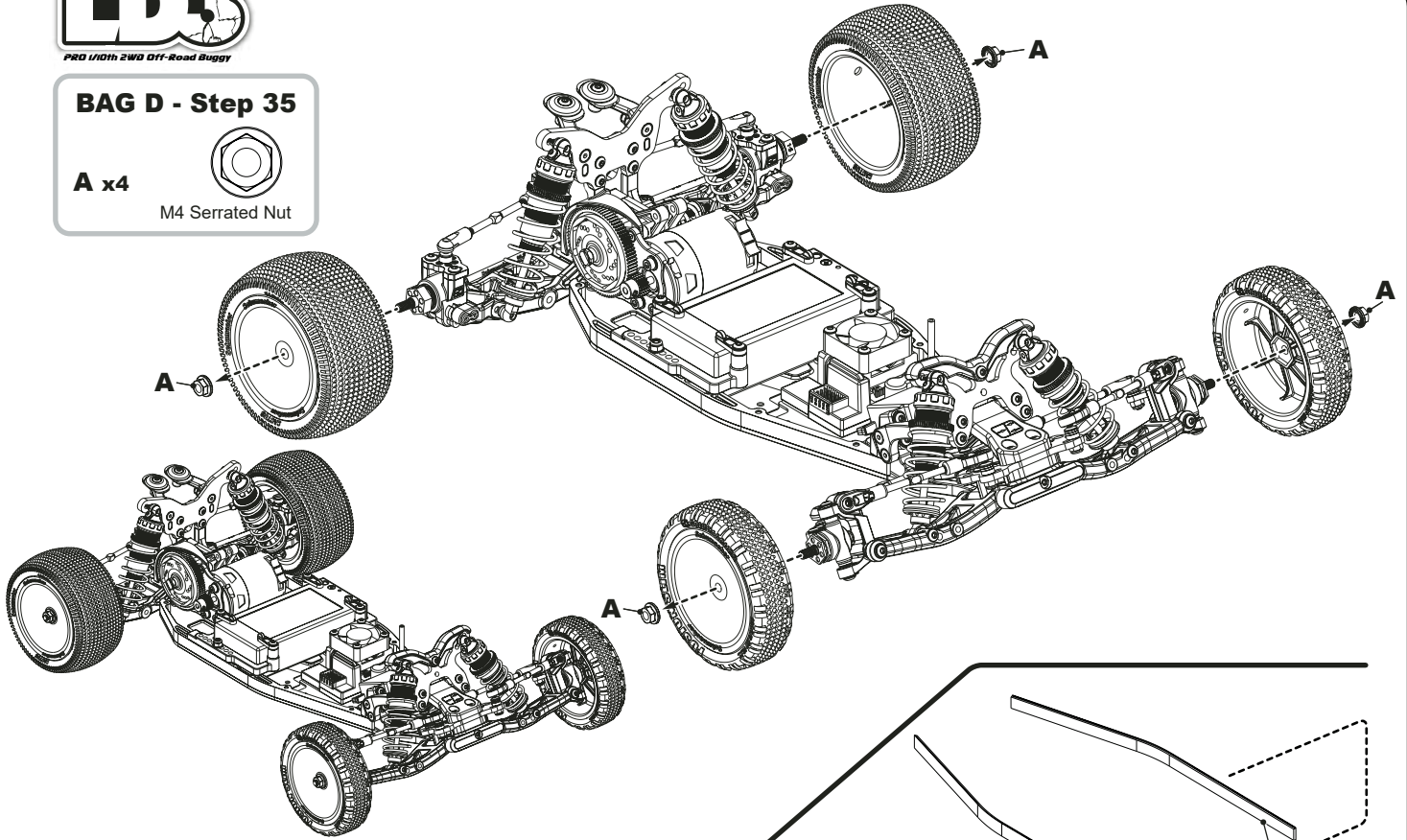

BAG D - Step 36



RACE TIP

Some racers use super glue to attach the velcro to the sidepods.

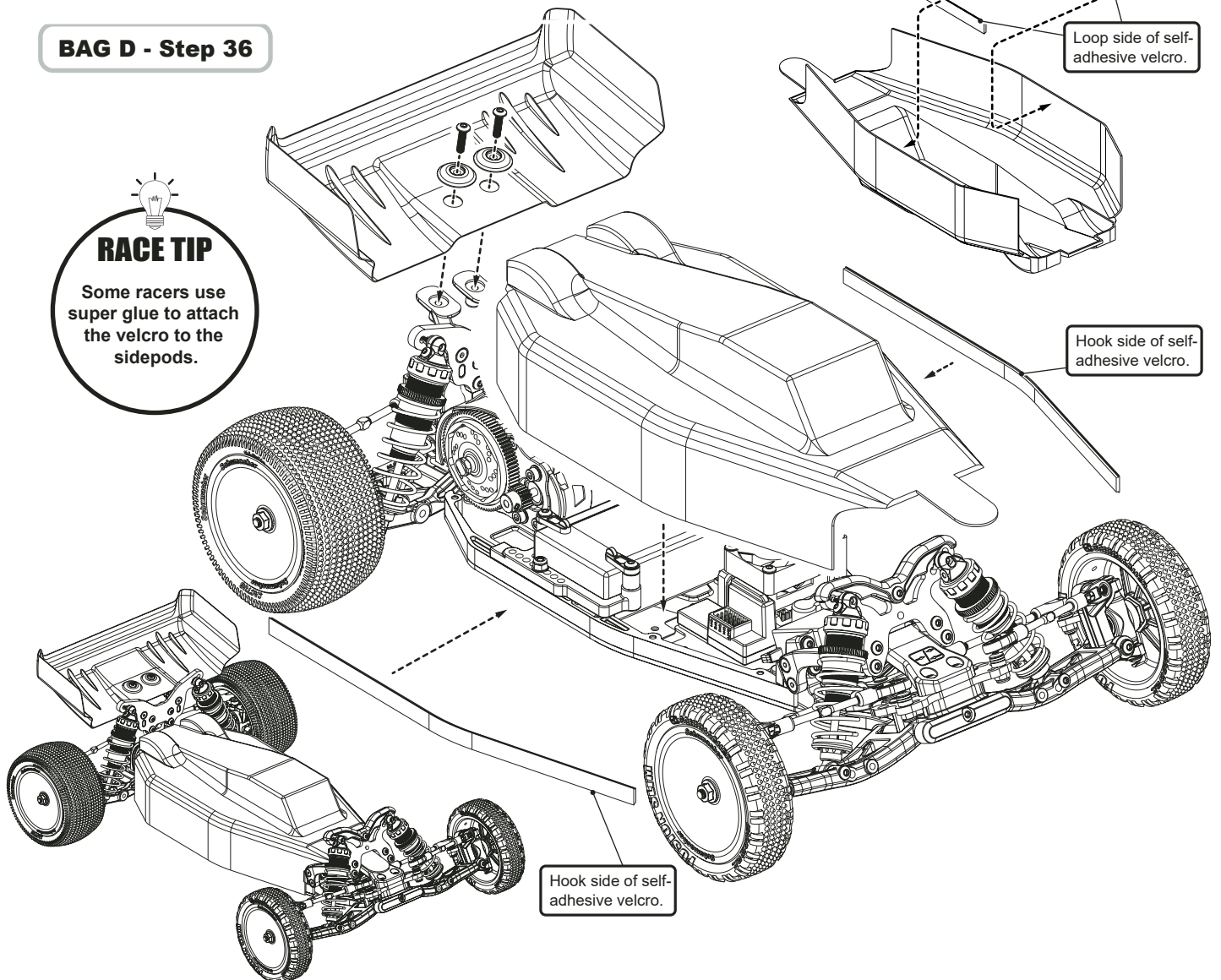



PRO 1/10th 2WD Off-Road Buggy

REAR SHOCKS, OPTION POSITION - Build Instructions

A x2



Ball Stud Ultra Long

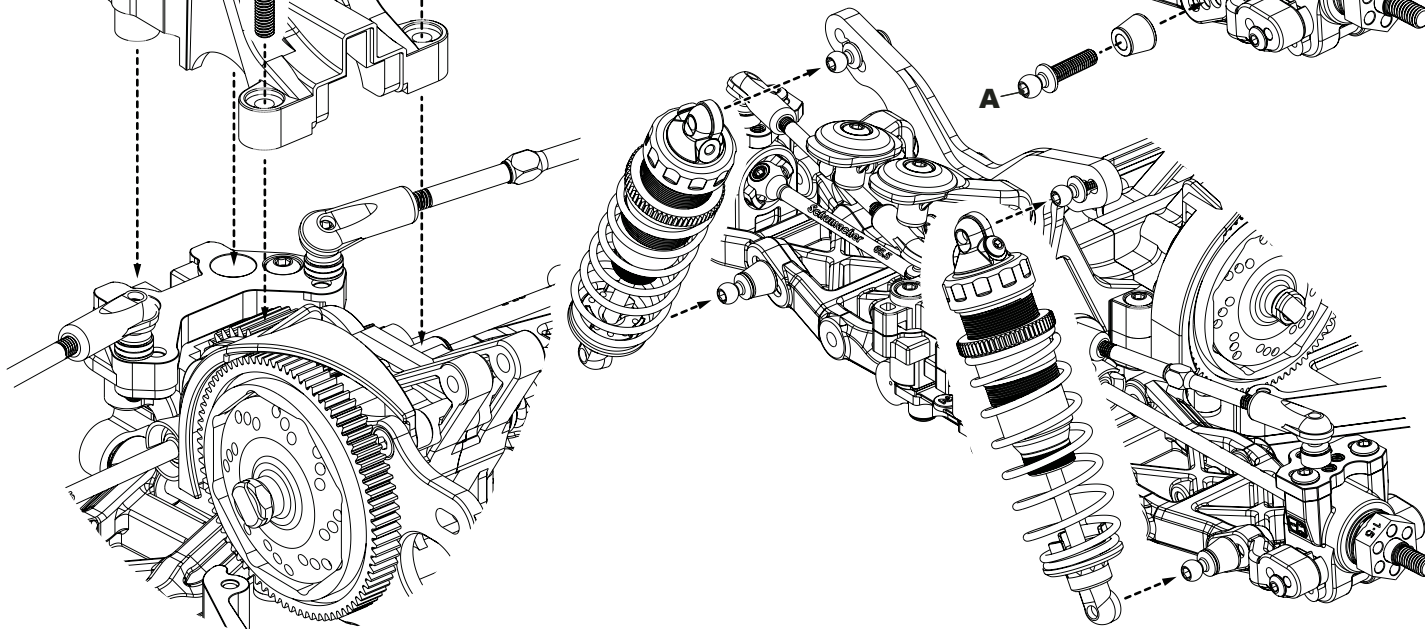
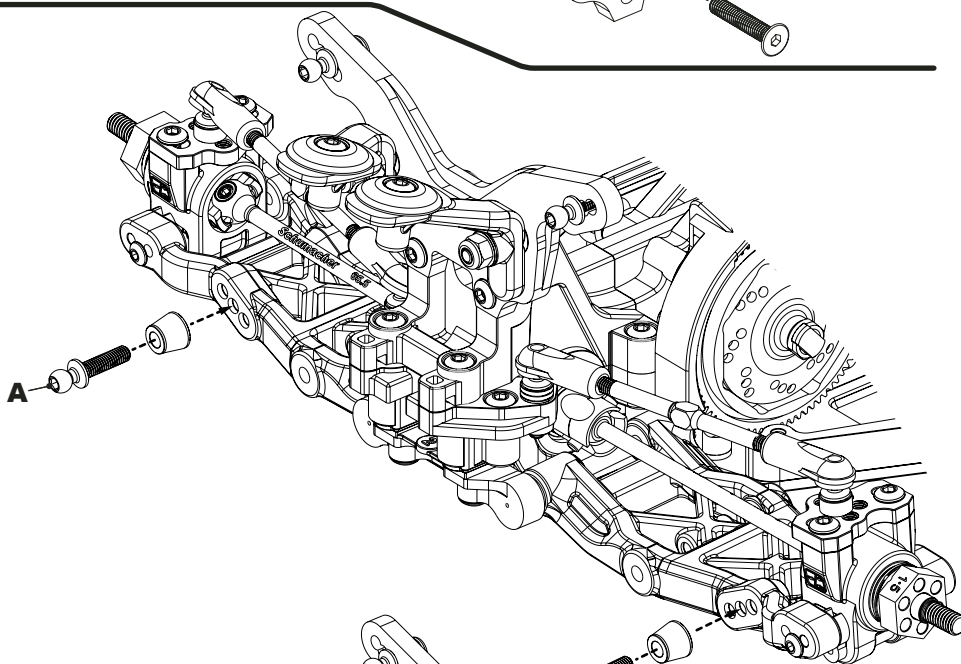
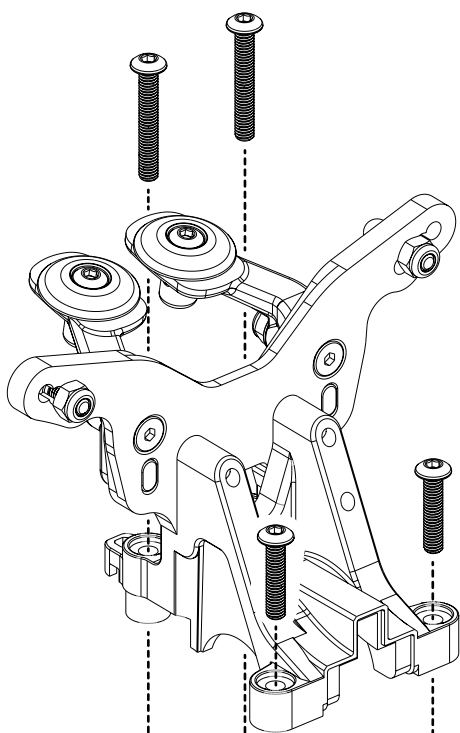
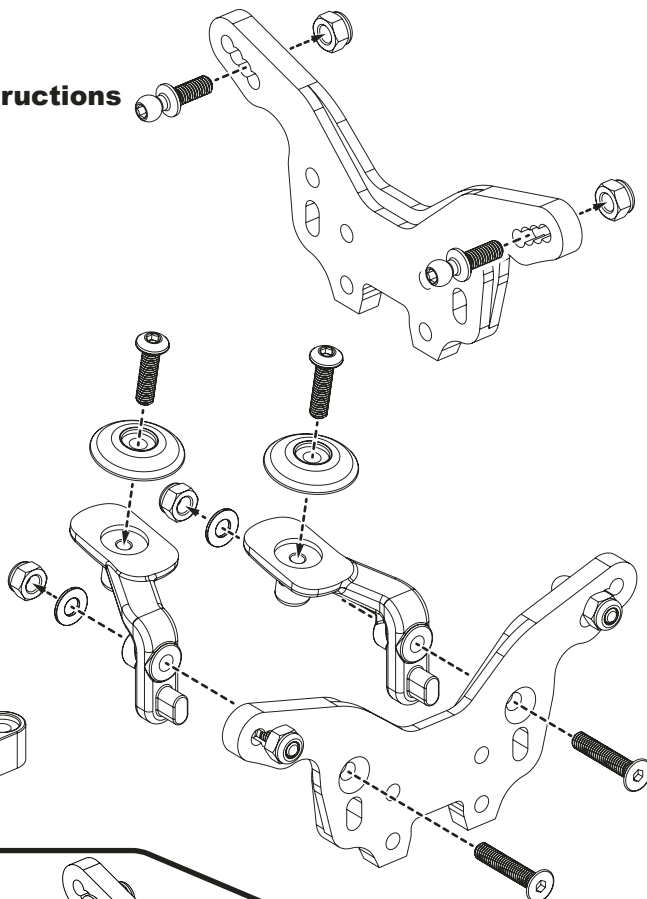
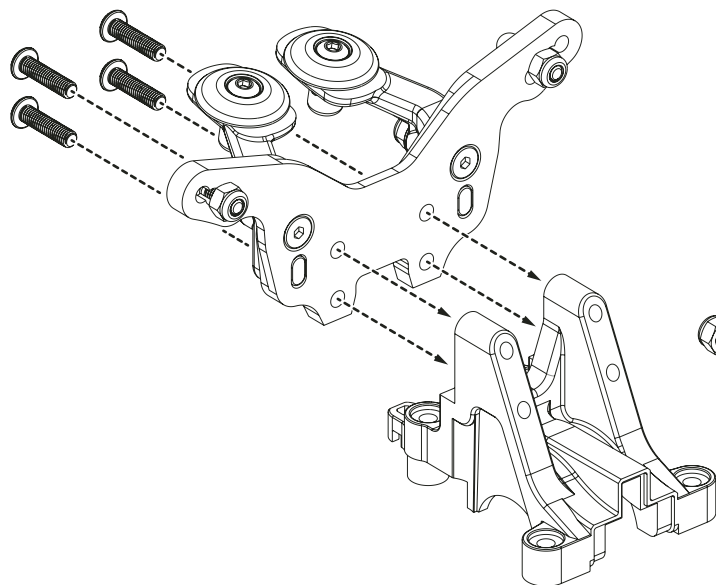

TRACK SETTINGS

RIDE HEIGHT

Use the spring adjusters on the shock absorbers to adjust the front and rear ride heights. With the car level, we recommend setting the ride height to around 19mm on astro, 23mm on dirt and 14-16mm on carpet. (16mm if there are large jumps in the track).

This is measured between the bottom of the chassis and the ground with the car in running trim. First press the car down on to the ground and release it once or twice to settle the suspension before adjusting the ride height. The chassis should be level when viewed from the side.

Adjusting the spring collars does not increase or decrease the spring stiffness only the preload.

If the suspension needs to be softer or harder change the spring.

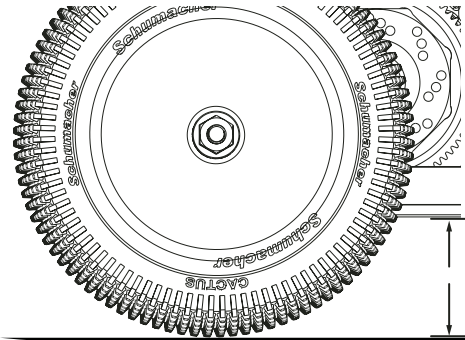

SLIPPER CLUTCH

See Page 14 Bag C - Step 24

On most tracks it is best to start with the slipper on a **LOOSE** setting, and gradually tighten the spring tension until you achieve the most consistent drive away from turns without spinning the car or pulling wheelies. Make sure you still have enough drive when launching the car from the up ramps. **WARNING**, do not run the slipper too loose as it could melt the plastic spur gear, also too tight may damage the transmission parts. If you are generating too much heat at your preferred setting, use **U8502** this will give you a more durable slipper clutch. When using the three plate conversion, compress the slipper spring fully, before setting spring tension for desired amount. Always use a new spring when reverting back to a 2 plate slipper.

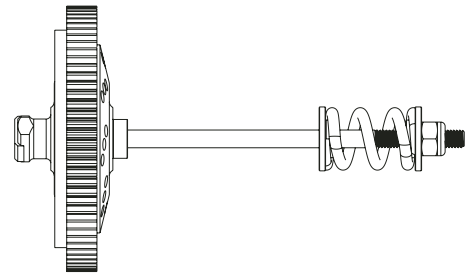

FRONT CAMBER

See Page 06 Bag A - Step 10a

The usual team setting for static front camber is 1-2° negative at ride height (the top of the wheel is leaning inwards towards the car). Increasing the static camber will generally increase the mid corner steering, whereas decreasing the static camber usually makes the car smoother to drive by reducing the steering response.

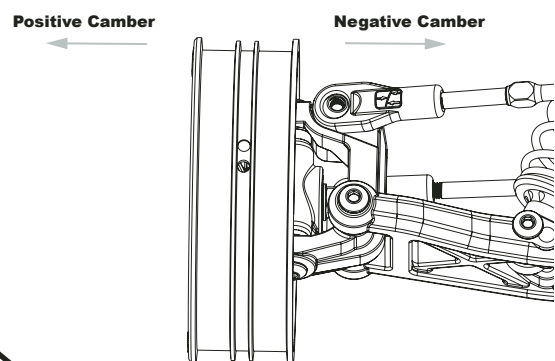

REAR CAMBER

See Page 06 Bag A - Step 10c

The usual team setting for static rear camber is 1° negative at ride height (the top of the tyre leaning inwards towards the car). Increasing the static rear camber will increase the traction when exiting the turns, but will be less stable at high speed. Decreasing the camber will reduce stability and traction in the turns but will be more stable at high speed. (Some drivers believe that adding slight positive camber where the tyre leans out at the top away from the car, will improve straight line traction on loose surfaces).

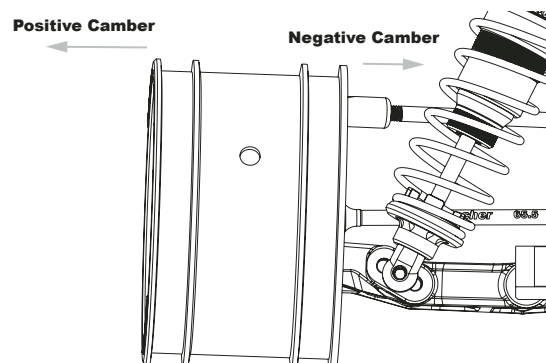

FRONT TOE

See Page 06 Bag A - Step 10b

Front toe should be set to 0° (both front wheels pointing straight ahead) this will be the best setting for most track conditions. Adding toe out will increase initial turn in and make it smoother to drive on power. The team generally run 1° toe out on Astro tracks.

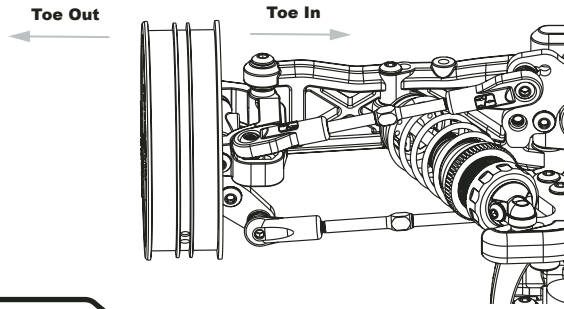

REAR TOE INSERTS

See Page 19 Bag D - Step 31

The base setting rear toe in is 3° this is a good compromise between forward traction and the car binding in the turns. This setting is fine for most tracks. You can alter the toe in by changing the toe in inserts. If you are running too much toe in, your car may suffer from instability at high speeds. Decreasing the toe in will reduce forward traction but will free the car up in the turns. Usually the team use less toe in on high grip tracks and more for low grip tracks. A good starting position is 1.5° on carpet and 3.0° on low grip dirt and wet astro. The eight blocks have indicators on top of them to show the amount of toe-in each one has. The range is 0.5° to 4.0°.

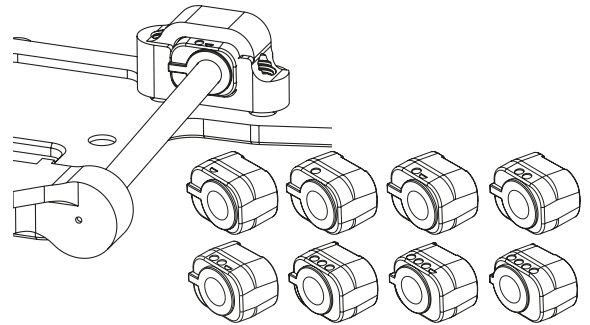

REAR ANTI SQUAT SPACERS

See Page 19 Bag D - Step 32

The kit build antisquat is set at 1°. This works best on most tracks, and with the included parts this can be increased or decreased. Generally less antisquat allows the suspension to work better over the large bumps and gives more power on steering. Increasing Anti-Squat will offer more initial steering and as the rear becomes stiffer, the rear will jump more.

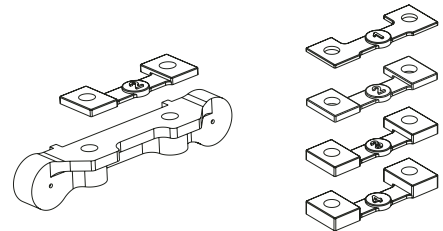

FRONT CAMBER LINKS

See Page 09 Bag B - Step 15 & Page 10 Bag B - Step 17

The kit front camber link position and length are what the team recommend for most tracks. Using a long front link makes the front of the car roll more and will give less steering reaction at high speed. It is also not quite as good on very bumpy tracks. We would recommend this on fairly smooth high grip tracks. A shorter front link will make the car roll less and quicken the initial steering response. This is a better choice for bumpy low grip tracks. Lowering the inside ball stud will give a similar result to shortening the link, and raising it will give a similar result to lengthening the camber link, but with less total effect.

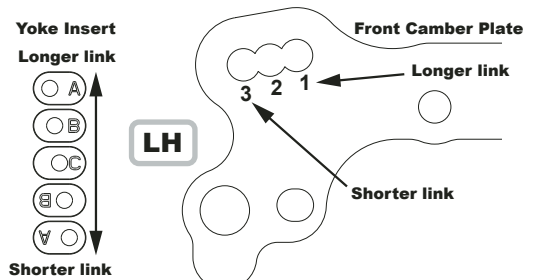

REAR CAMBER LINK

See Page 19 Bag D - Step 31 & 32

The kit build rear camber link setting is the best compromise for most tracks. Lengthening the rear camber link will make the rear of the car roll more in the corners, and square up slower when accelerating away from tight turns, longer links are generally used on high grip tracks and shorter links on low grip tracks. Lowering the inside ball stud will give a similar result to shortening the link, and raising it will give a similar result to lengthening the camber link, but with less total effect.

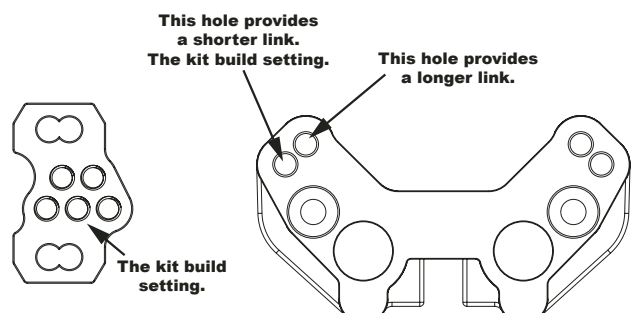

ANTI-ROLL BARS (SWAY BARS) *Options

Anti-roll bars are an often overlooked set up aid that allows fine tuning of the suspension without major changes to the shock and spring settings. They are mainly used to add roll stiffness to the car without affecting the handling on bumps and jumps. Running anti-roll bars allows you to run softer suspension on bumpy tracks while reducing the roll in corners thus maintaining stability through the turns.

On the front use a 0.9mm anti-roll bar if you wish to keep the car flat in the corners. The rear anti-roll bar thickness is very dependent on the track surface/layout. On carpet, use a 1.2mm. On astro, start with a 1.0mm and for more initial steering try 1.1mm. If you need to use 1.2mm consider softening the rear spring.

BALL DIFFERENTIAL *Option

See Page 05 Bag A- Step 9

The dirt car comes with the ball diff in the kit.

We recommend the ball differential is used for loose or wet conditions. For consistent performance it is vital that the differential action should be smooth and free. Diff adjustment is not a tuning aid and the diff should never be allowed to slip. A loose diff can usually be recognised by a "chirping" sound when powering away from turns or landing under power from large jumps.

Never allow the diff to run dry. Regularly re-apply the grease, packing lots of grease into the holes before inserting the balls. This increases the performance life of the diff. Run the diff in and then reset the tension. Only use the recommended greases.

U7698 - V3 Ball Diff Complete KD/Laydown/KR/Storm

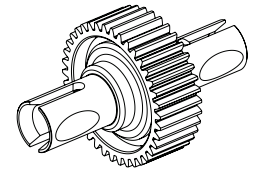

GEAR DIFFERENTIAL

See Page 04 Bag A- Step 9

The gear differential is included in the LD3M and LD3S kits.

Geared Diffs can give variable driving characteristics. The handling of the diff is tuned by changing the oil. A recommended starting point is 12,000 cSt (CR229). Recommended option oils would be 10,000 cSt (CR222) and 7,000 cSt (CR221). Running two gears will give more drive and off power steering. Use 7,000cSt on high grip tracks, if you start spinning a wheel on power, go up on oil until it stops.

We recommend changing the oil more often when running 2 gears.

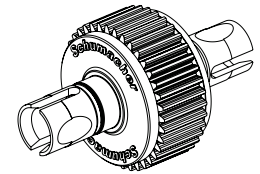

FRONT WHEELBASE OPTIONS

See Page 12 Bag C - Step 21

There are three ways of adjusting wheelbase.

1. The adjustment is provided by re positioning the 1.5mm washer on the outboard pivot.

This only moves the hub carrier, it will not affect the angle of the shock absorber. Moving the hub carrier rearwards will give more traction at the expense of stability over rough sections of the track, and moving the hub carrier forwards will usually improve stability over the rough sections.

2. The front wishbones can be swapped left to right to alter the offset of the outer end of the wishbone. The standard offset is forward. Swapping the wishbones left to right will move the front hub carrier rearwards by 1.5mm. This only moves the hub carrier, it will not affect the angle of the shock absorber.

Moving the hub carrier rearwards will give more traction at the expense of stability over rough sections of the track, and moving the hub carrier forwards will usually improve stability over the rough sections.

3. By removing the chassis insert, the chassis length can be reduced by 5mm. This will improve agility and front end grip on high grip tracks.

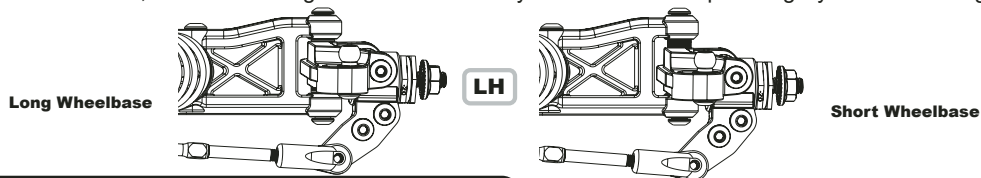

REAR WHEELBASE OPTIONS

See Page 17 Bag D - Step 29

The Cougar LD3 has 4 wheelbase options at the rear, short, mid short, mid long and long.

The adjustment is provided by re positioning the quick clips on the outer wishbone pin.

Moving the rear hub carrier forwards will give more traction at the expense of stability over rough sections of the track, and moving the hub carrier to the middle or rear position usually improves stability over the rough sections, running the car in long wheelbase form also free's up the car on sweeping sections of the track. Generally you will run long wheelbase on carpet, mid on astro and short on dirt.

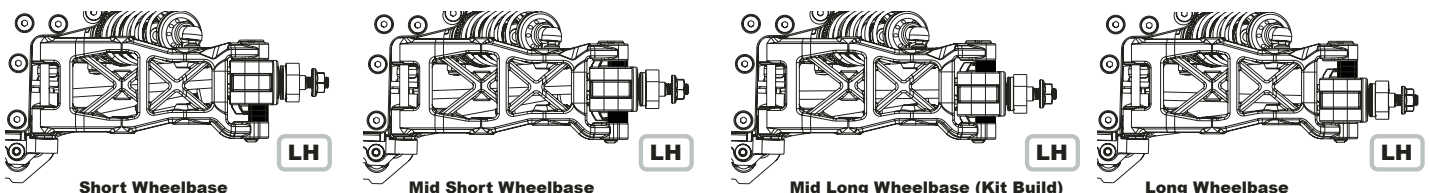

FRONT SHOCK MOUNT

See Page 09 Bag B - Step 16

Hole 3 on the front shock mount is the most widely used position. Moving the shock to the outer position will make the car react faster and increase the initial steering response, it will however stiffen the suspension which may require an oil and spring change so that the cars suspension feels the same. Moving the shock to the inner hole will soften the suspension and slow down the steering reaction and make the car smoother on bumpy tracks. Again you may need to alter the oil and spring combination to get the suspension correct again.

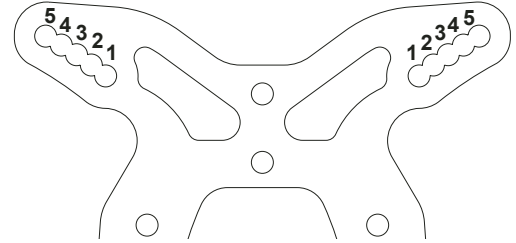

REAR SHOCK MOUNT

See Page 16 Bag C - Step 27

Hole 2 on the shock mount gives best all round results. Moving the shock to the outer hole will stiffen the suspension and increase the reaction of the steering. The downside is less compliance over bumpy sections of the track. Moving the shock to the inboard position softens the suspension and will slow the steering reaction making the car smoother over the bumps. Moving the shock to these holes may require an oil or spring change to maintain the suspension performance. The rear shock mount is assembled to the front of the transmission as standard, moving the mount to the rear of the transmission makes the car less reactive but more stable.

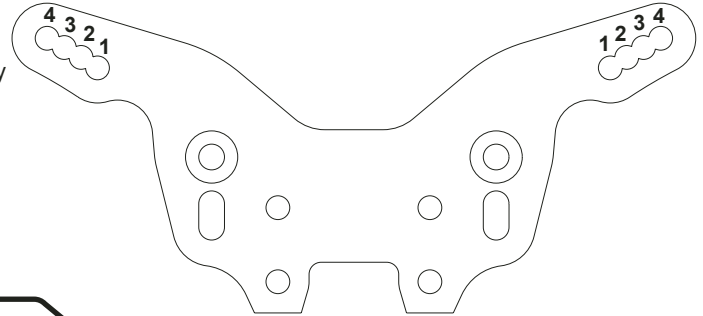

ACKERMANN

See Page 07 Bag B - Step 12

The kit build setting of 2mm is the teams preferred position. If you run more shims/washers up to 3mm you will find that the initial steering will be slightly more aggressive but you will find mid to exit steering much smoother. You will generally gain only a small amount of initial steering but you will lose a greater amount of mid to exit steering. Using less washers by changing from 2mm down to 1mm will give you more mid corner steering and grab more at this moment. Consider that it could make the buggy a little more difficult to drive and slow the buggys speed in the corner down. If running the Speed secret 'Alloy Centre Track Rod U8205' you will have the option for a lower ball stud threaded hole to connect the steering link to. Running the kit higher setting will make the car more reactive around initial steering throw. You will find this option hole makes the car easier to drive. Optional 'A', 'B' and 'C' steering arms are another way of changing the ackermann. Arm 'A' gives the car more steering and is the most aggressive setting. Arm 'B' gives smoother initial steering. Arm 'C' offers the smoothest steering feel, making the car easy to drive even on twitchy, bumpy tracks.

LIPO POSITION

See Page 21 Bag D - Step 34

There are 8 shorty LiPo positions available to fine tune the chassis. For increased traction run the rearward LiPo position (Positions 6,7,8). For increased steering run the forward Lipo position (Positions 1,2,3). For a balanced feel run the mid LiPo position (Positions 4,5).

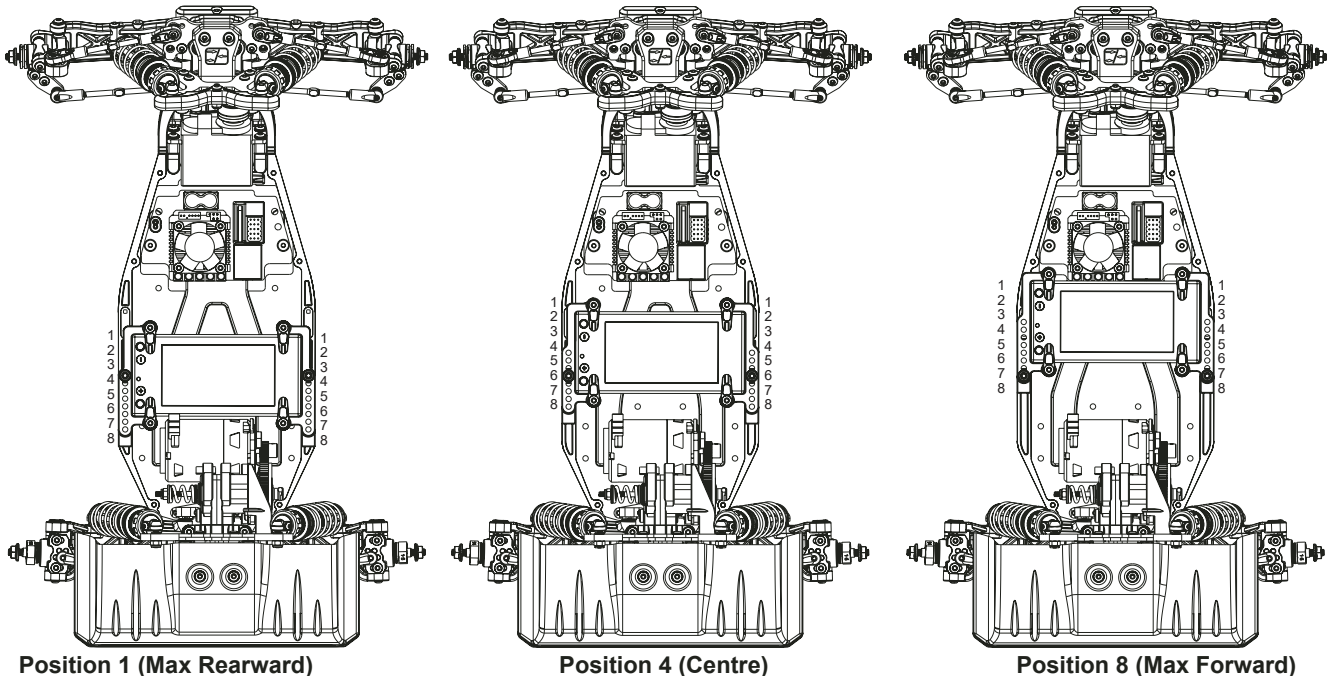

Position 1 (Max Rearward)

Position 4 (Centre)

Position 8 (Max Forward)

DIFFERENTIAL HEIGHT

See Page 16 Bag C - Step 26

The base setting is Low diff.
Raising the diff is better for jump landings.
Lowering the diff improves bump stability and allows you to run higher ride heights. Running the diff high on carpet will help loosen side grip. On more open tracks a lower diff will help increase corner speed.

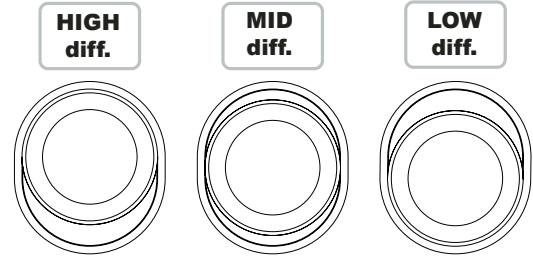

FRONT YOKE

See Page 10 Bag B - Step 17

The Cougar LD3 has a rake angle (kick up) of 25°. This should be added to the castor block angle to get the total castor angle.
The standard car uses a 5° castor block making the standard car 30° in total. This can be decreased to 27.5° by using the optional 2.5° castor block.
The 30° angle will increase on power steering and stability.
The use of less castor will increase initial turn in.

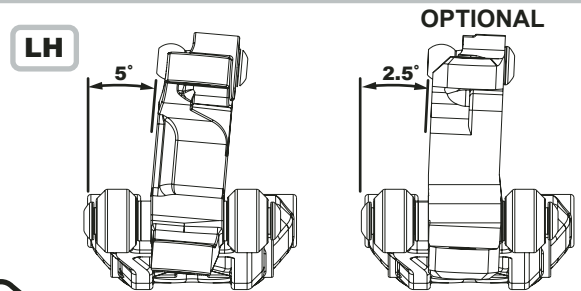

PIVOT BLOCK HEIGHT *Option

See Page 07 Bag B - Step 13

The Cougar LD3 provides the option to adjust the front pivot block height using spacers. The kit build pivot block position is high – 1mm spacer between the pivot block and bottom plate. The low position is achieved by removing the 1mm spacer from between the pivot block and bottom plate, and replacing it with the optional 1mm spacer between the link mount and top plate. The team have found when running in the lowest position that you reduce the initial steering a small amount, but in turn gain mid to high speed steering. There is also an option to place the pivot block in the mid position, with a 0.5mm spacers located top and bottom (U8207). The pivot block spacing must always total 1mm (bottom+top).

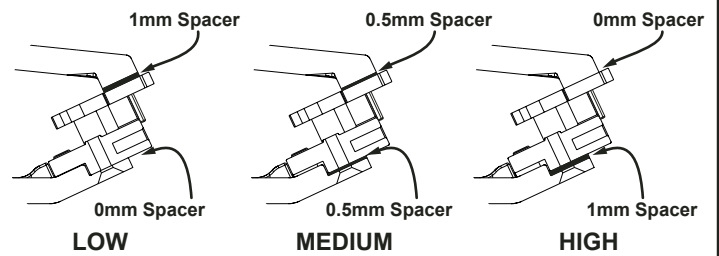

FRONT WISHBONE SHOCK MOUNTING HOLE

See Page 11 Bag C - Step 20

The outboard hole on the wishbone is the standard setting for most tracks. Moving the shock to the inner hole makes the car more reactive. It increases the initial turn in and makes the front of the car roll more through the turns. This setting also makes the front end softer.
Moving the shock out will support the front and keep the car flatter. The car will pick up a wheel on power, if the rear is too soft. Then consider using a softer front spring.

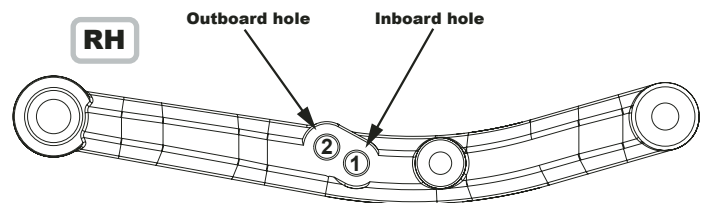

REAR WISHBONE SHOCK MOUNTING HOLE

See Page 17 Bag D - Step 29

The middle hole works best for most track conditions giving good traction and drive through the turns whilst maintaining good stability over the bumps. Moving to the outer hole on the wishbone will decrease traction but will allow the rear to free up more in the turns. This setting would usually only get used on high grip tracks and when moving the shock out you may have to change the oil and spring settings to get the same suspension feel. If the grip level is low and the track is bumpy, try the inside hole with harder springs and thicker oil. This should help improve the handling.

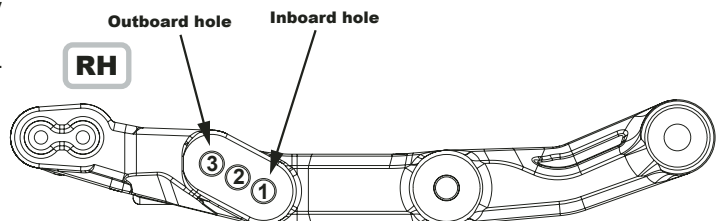

REAR HINGE PIN HEIGHT

See Page 15 Bag C - Step 25 & Page 19 Bag D - Step 32

The kit is built in the high setting, this offers the highest roll stiffness which gives the feeling of forward drive. We find it makes the car more responsive and you gain initial steering in this kit position. Running the low hinge pin position you need to remove the thin strip from the RF strap and adding in the 1mm strip with the anti squat spacer between the RR strap and the housing. The lower position will give you more on power steering. The team have found in low grip conditions that to have drive with this setting you must stand the shock up on the tower, consider a harder spring when you use this setting too.

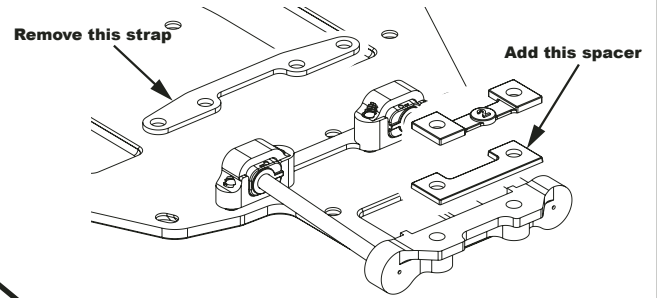

FRONT & REAR HEX WIDTH

See Page 14 Bag B - Step 20 & Page 18 Bag D - Step 30

The base setting gives the best balance between steering and stability. Using a wider front hex will make the car more aggressive. Using a wider rear hex will help with more forward drive and initial turn in. Narrowing the rear will give more on power steering and increase side traction.

REAR HEX OPTIONS			
Part Number	Hex Width	Car Width Change	ID
U8619	4.00	3.5mm Narrower	-2.0
U8429	4.50	3.0mm Narrower	
U7646	5.25	2.25mm Narrower	-.75
U7398	6.00	1.5mm Narrower	0
U7402	6.75	0.75mm Narrower	.75
U7403	7.50	Standard Width	1.5

FRONT HEX OPTIONS			
Part Number	Hex Width	Car Width Change	ID
U8619	4.00	Standard Width	-2.0
U8429	4.50	0.5mm Wider	
U7646	5.25	1.25mm Wider	-.75
U7398	6.00	2.0mm Wider	0
U7402	6.75	2.75mm Wider	.75



The LD3D has the U8619 hex on the rear as the kit option. The width change column is for the LD3M and LD3S only.

GEAR RATIO (2.53:1)

See Page 14 Bag C - Step 24

Pinion Gear

Spur Gear		17	18	19	20	21	22	23	24	25	26	27	28	29	30	31	32	33
	80	11.92	11.26	10.67	10.13	9.65	9.21	8.81	8.44	8.11								
	78			10.40	9.88	9.41	8.98	8.59	8.23	7.90	7.60	7.32						
	76					9.17	8.75	8.37	8.02	7.70	7.41	7.13	6.88	6.64				
	71										6.92	6.66	6.42	6.20	6.00	5.80	5.62	5.45

Tooth Sum 97 Minimum to 105 Maximum

Use steel pinions when running on a dusty, gritty track.
Use hard alloy pinions when running indoors on 'clean' surfaces e.g. carpet.

RADIO TRAY POSITION

See Page 20 Bag D - Step 33

Similar to adjusting the LiPo position, the radio tray can be used to adjust the cars weight balance. Running Kit Build forward position (3), you will have maximum steering and a settled front end while jumping. Moving the tray further back is better for twitchy or low grip conditions.

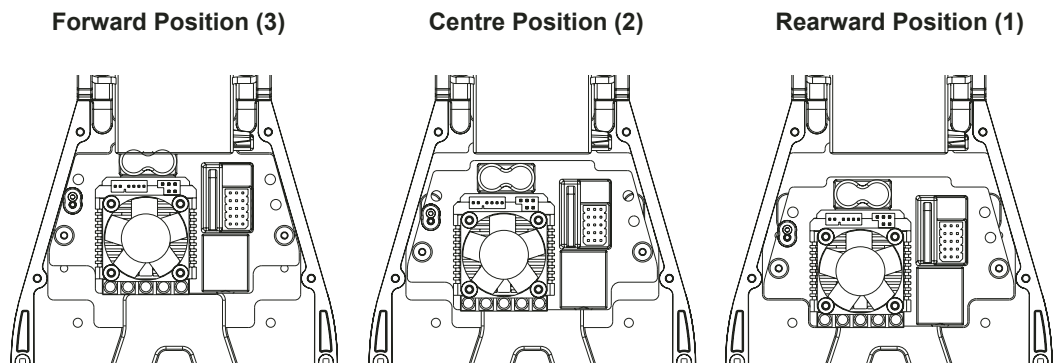

DRIVESHAFTS

Universal joint (U/J) driveshafts offer greater bump handling than the kit CVD driveshafts. They also offer more on power steering, suitable for carpet tracks.

VARIABLE LENGTH REAR WISHBONES

See Page 17 Bag D - Step 29

The base setting is long wishbone. This setting gives the most on power steering and is the most stable on landing from jumps.

The short wishbone setting will give more rear grip on loose surfaces. When running this setting you need to soften the suspension.

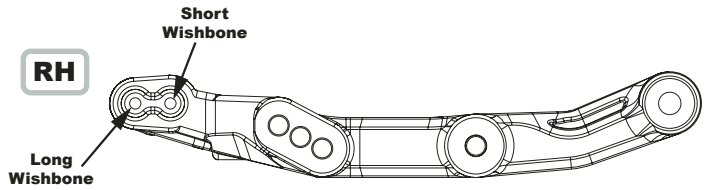

FRONT PIVOT BLOCK WEIGHT *Option

See Page 07 Bag B - Step 11

The team have found the alloy pivot block (U8211) to be their common setting, they have found that it gives good reaction from the front end and is more durable in tough conditions.

The brass option (U8212) will add a lot of weight to the front and slow down direction change. It offers also a safe feeling when running on high grip astro but will slow down the response of the front end which can in some cases benefit the driver on twitchy high grip tracks. If you run in low grip you should run the Alloy option as this will keep the cars balance more in the middle of the car. The brass is most commonly used on carpet as it helps to keep the nose of the truck down.

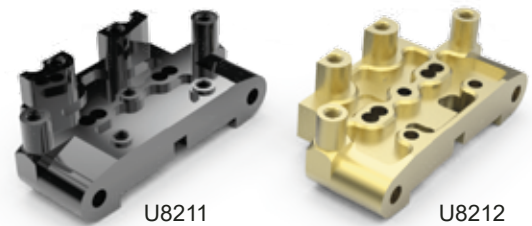

PIVOT BLOCK STEERING ARM MOUNTING

See Page 07 Bag B - Step 11

The kit build position of number 2 offers the most aggressive feel for the steering.

Position 1 will offer reduced aggression throughout the steering arc and feel smoother to drive. However, you MUST use either AX009 (25T) or AX010 (23T) alloy servo horns when using this option. See page 34.

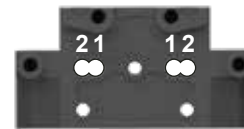

FRONT HUB HEIGHT

See Page 10 Bag B - Step 18

Changing the spacers under and above the hub will change the axle height.

Raising the axle will increase on power steering, decrease initial steering and give a safer car under braking. Lowering the axle will increase initial steering. If the car is breaking traction out of corners it's a sign of the axle being too high or too much castor angle.

The example shows a 2mm spacer on the top and 1mm on the bottom. This shows a 1mm Front Hub Height.

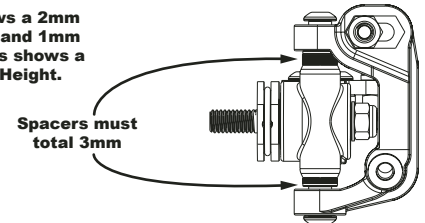

REAR HUB HEIGHT

See Page 18 Bag D - Step 29

The kit hub position is 0.0mm (Insert A or Insert E) hub height.

Decreasing hub height will add some side grip and make the car feel like it rolls more.

If you increase the height the car will feel like it rolls less and has less side bite. This will also help the car drive out of the corner. When using suspension inserts that give more than +1.0mm hub height, shock length and shock stroke must be corrected. To correct the stroke, add an O'Ring to the shock shaft above the spring seat. The length of the shock should be increased by unscrewing the shock socket by the difference between the chosen hub height and the kit setting.

	Wide Pin		Hub Height	Narrow Pin		Hub Height	Mid Pin	
	Suspension Inserts	Suspension Inserts		Suspension Inserts	Suspension Inserts			
Hub Low	A	A	0.0mm	A	A	Hub Low	E	E
	B	B	+0.5mm	B	B		F	F
	C	C	+1.0mm	C	C		G	G
Hub High	D	D	+1.5mm	D	D	Hub High	H	H
	C	C	+2.0mm	C	C		G	G
	B	B	+2.5mm	B	B		F	F
	A	A	+3.0mm	A	A		E	E

TOE-IN STRAP WEIGHT Front *Option

See Page 15 Bag C - Step 25

Using the optional U7665 Brass FR Strap will add approximately 12g. This will offer more traction, particularly useful in lower grip conditions.



TYRES, WHEELS & INSERTS



2WD Slim Mini Spike 2

- U6549 - Blue Compound (pair)
- U6550 - Green Compound (pair)
- U6581 - Yellow Compound (pair)
- U6761 - Silver Compound (pair)



**Low Profile
2WD Slim Cut Stagger**

- U6770 - Yellow Compound (pair)
- U6771 - Green Compound (pair)
- U6775 - Silver Compound (pair)
- U6776 - Blue Compound (pair)



Wheels

Neon Yellow

- U7460 - Rear (Pair)
- U7461 - Rear (5 Pairs)
- U7456 - Front Med (Pair)
- U7457 - Front Med (5 Pairs)
- U7454 - Front Slim (Pair)
- U7455 - Front Slim (5 Pairs)

White

- U4366 - Rear (Pair)
- U7469 - Rear (5 Pairs)
- U4368 - Front Med (Pair)
- U7467 - Front Med (5 Pairs)
- U4661 - Front Slim (Pair)
- U7466 - Front Slim (5 Pairs)

Black

- U4365 - Rear (Pair)
- U4367 - Front Med (Pair)
- U4660 - Front Slim (Pair)

Tyres



Rear Mini Spike 2

- U6516 - Green Compound (pair)
- U6518 - Blue Compound (pair)
- U6558 - Yellow Compound (pair)
- U6763 - Silver Compound (pair)



Rear 2.2" Full Spike

- U6596 - Yellow Compound (pair)



Rear Honeycomb

- U6863 - Yellow Compound (pair)



Rear Mini Dart

- U6826 - Yellow Compound (pair)
- U6829 - Blue Compound (pair)
- U6832 - Silver Compound (pair)



MEZZO

- U6885 - Yellow Compound (pair)
- U6886 - Silver Compound (pair)
- U6887 - Blue Compound (pair)



Rear Cactus

- U6838 - Yellow Compound (pair)
- U6842 - Silver Compound (pair)
- U6844 - Blue Compound (pair)

Foam Inserts



Front Slim

- U6738 - Med (pair)
- U6667 - Hard (pair)



Front Med

- U6733 - Med (pair)
- CR689 - Closed Cell (pair)



Rear

- U6653 - Hard (pair)
- U6668 - Soft Ultra Wide (pair)
- U6669 - Hard Ultra Wide (pair)
- U6734 - Med (pair)
- U6747 - Med Tubby (pair)
- MC0002 - Cragg KWF (pair)
- CR687 - Closed Cell (pair)

Pre-Glued

Yellow Compound Tyres
White 12mm Hex Wheels

2WD Slim Front

- U6753 - Mini Spike
- U6755 - Mini Pin
- U6760 - Cut Stagger
- U6801 - Cut Stagger Low Pro
- U6833 - Mini Dart

2WD Med Front

- U6860 - Honeycomb

Rear

- U6792 - Mini Pin
- U6794 - Mini Spike2
- U6806 - Mini Pin 2
- U6818 - Mini Pin 1
- U6835 - Mini Dart
- U6839 - Cactus
- U6864 - Honeycomb

For the full and latest range of off-road tyres, scan the QR code.

Or visit www.racing-cars.com and check out Products > Wheels & Tyres.



SPARES LISTS

Chassis Parts

U119	Aerial Tube - Pack 4
U3691	Servo Spacer - SV/2,SVR,KR,KF/2,KD,KC,LD\2,ST
U4689	Steering Pivots Short-K2,KF2,Mi6/ev0,KD/C,LD/2,ST
U4773	Aerial Mount
U7339	Front Carpet Protector - LD/2,L1/EVO/R
U7952	Wing Mount Mouldings - LD2,L1 EVO/R
U7970	M2.5 Thread Insert pk10 - L1 EVO/R,ST,LD2
U8051	Radio Plate S2 - Storm ST,LD2
U8187	Top Plate - LD2
U8188	Bottom Plate - LD2
U8190	Chassis Inserts - LD2
U8194	LiPo Mouldings - LD2
U8195	Servo Horn Fixed Mouldings - LD2
U8198	Centre Track Rod - LD2
U8560	Steering Link - ST2
U8609	Alloy Chassis - LD3
U8610	Side Pod (pr) - LD3
U8615	S2 Front Shock Mount - LD3
U8616	S2 Rear Shock Mount - LD3
U8617	S2 Front Link Mount - LD3
U8632	C/F Chassis - LD3
U8636	Manual - LD3
U8643	Front Pivot Block - LD3
U8644	Front Bumper - LD3

Bodys & Decals

AX005	Aerox Wing CAT L1/EVO/R,LD/2 - 1.0mm
AX019	Aerox Front Wing - LD2
AX020	Aerox Wing CAT L1/EVO/R,LD/2 Carbon - 1.5mm
AX021	Aerox Wing CAT L1/EVO/R,LD/2 Black - 1.5mm
AX022	Aerox Wing CAT L1/EVO/R,LD/2 White - 1.5mm
AX037	Aerox Trident Wing 1.0mm
JC0168	JConcepts-B6.3/B74.1 Rear Wing, 2pc
JC0169	Aero B6.3/B74.1 Rear Wing-Short Chord, 2pc
JC0173	JConcepts-Aero S-Type B6.3/B74.1 Wing, 2pc
JC0181	JConcepts-Aero S-Type 7inch Rear Wing, 2pc
JC0197	JConcepts Carpet Astro High Clearance Rear Wing
JC0432	Cougar LD3 Body
JC0432L	Cougar LD3 Body - Lightweight
JC0501	Carpet/Astro High-Clearance 7" Rear Wing
JC0503	Carpet/Turf/Dirt, 6.5" Wing - pre-cut
JC0504	Carpet/Turf/Dirt, 7" Wing - pre-cut
KRC-MFWING	Klinik RC - Max Flow Wing (2)
PCB007	Penguin Emperor Wing - 1mm
PCB010	Penguin King Wing - 1mm
PCB016	Penguin Rockhopper Wing - 1mm
PCB031	Penguin Royal Wing - 1mm
U8586	Schumacher Decal Sheet - Black - pk2
U8587	Schumacher Decal Sheet - Neon Blue - pk2
U8588	Schumacher Decal Sheet - Neon Green - pk2
U8589	Schumacher Decal Sheet - Neon Orange - pk2
U8590	Schumacher Decal Sheet - Neon Pink - pk2
U8637	Decal - LD3

Suspension

U3708	Kwik Clips 2.4 x 2.0mm (pk4) - 2WD/4WD
U3729	WishbonePivot Spheres pk4 - Cougar,ST
U4224	Turnbuckle Adjuster HTT - 60mm - pr
U4274	Pro Ball Stud Short - pk4
U4275	Pro Ball Stud Long - pk4
U4299	Turnbuckle HT - 52mm - pr
U4700	Pro Ball Stud - Ultra Long - (pk4)
U4704	Fluted Ball Grippa - Grey (pk8)
U4707	Short Ball Grippa - Grey (pk8)
U4775	Pivot Ball 5.5mm - (4pcs)
U4850	Low Ball Stud pk4 - A1,A2,L1/EVO/R,E1-E4
U7083	Rear Strap Spacers - Cougar KD,KC,L1/EVO/R,LD/2,ST
U7337	Radius Arms pr - L1/EVO/R,LD2
U7628	Rear Toe-In Inserts 8prs - LD/2,L1 EVO/R,ST
U7634	Strap Spacers 2pcs - LD/2,ST
U7636	Rear Link Mount - LD/2,ST
U7644	Alloy FR Strap - LD/2,ST
U7649	Alloy Shock Standoff pr - LD/2
U7672	Turnbuckle Adjuster HTT - 56mm - (pr)
U8200	Front Inboard Pivot Pin - LD2 (pr)
U8204	S2 Front Pivot Block Spacers - LD2
U8296	Rear Hub Carrier - L1R (pr)
U8297	Alloy Rear Hub Plate - L1R (pr)
U8311	Rear Hub Carrier Inserts - L1R (4 prs)
U8400	5.5mm Long Socket - L1R (4 pcs)
U8545	Front Hubs (pr) - ST2
U8547	Wishbone Pivot Bush (4pcs) - ST2
U8548	Yoke Pivot Bush (4pcs) - ST2
U8550	S2 Front Steering Arms (pr) - ST2
U8551	Front Yoke Inserts (3 sets) - ST2

U8552	Front Yokes; 5 Degree - ST2
U8559	5.5mm Pro Ball Stud Extra Long (4pcs)
U8607	Front Axle (pr) - LD3
U8611	Alloy Rear Suspension Strap - LD3
U8612	Rear Wishbones Med Flex - LD3
U8613	Rear Outboard Pivot Pin (pr) - LD3
U8614	Rear Inboard Pivot Pin (pr) - LD3
U8625	Alloy FR Strap Layback - LD3
U8629	Rear Hub Carrier Inserts E-H - LD3
U8634	Front Wishbones Med Flex (pr) - LD3

Transmission

U2761	Diff Shims; 10x12x0.2 (pk8)
U3311	Axle Spacers 5x7 2prs - Off Road
U3364	Slipper Pad; PTFE Octagon pr - Off Road
U3834	Driveshaft; Pivot;Pin;Screw-Mi4-Mi6/SVR,KR,LD/2,ST
U4004	Diff Gear; 38T CNC - SV2,SVR,KR
U4176	Gear Diff Gear Set - Off Road,FT
U4386	Gear Diff Output - KR,LD/2,ST
U4674	Slipper Spring Bush - Off Road
U7065	Slipper Spring Twin Plate - 2WD/4WD
U7066	Diff Output Pin pr - KD,KC,L1/EVO/R,ST,LD2
U7068	Eccentrics 2 prs - KC,L1/EVO/R,LD/2,ST
U7403	Alloy Wheel Hex 7.5mm (+1.5) pr LD/2,L1/EVO/R,ST
U7615	80T 2,3,4 Plate Slipper Spur Gear
U7617	Right Hand Lower Trans - LD/2,ST
U7618	Left Hand Lower Trans - LD/2,ST
U7619	Upper Trans Forward - LD/2,ST
U7620	Upper Trans Rearward - LD/2,ST
U7622	Idler Shaft - LD/2,ST
U7629	Finger Guard - LD/2,ST
U7645	Alloy Motor Plate - LD/2,ST
U7662	CVD Rear Axle - LD/2,ST
U7671	Lockout 71T Spur Gear - LD/2,L1 EVO/R,ST
U7692	V3 Diff Washers + Balls - KR,KD,LD/2,ST
U7693	V3 Diff Male Washer Carrier - KR,KD,LD/2,ST
U7694	V3 Diff Female Washer Carrier - KR,KD,LD/2,ST
U7695	V3 Diff Thrust Race - KR,KD,LD/2,ST
U7696	V3 Diff T-Nut Inserts pr - KR,KD,LD/2,ST
U7697	V3 Ball Diff Service Kit - KR,KD,LD/2,ST
U7698	V3 Ball Diff Complete - KR,KD,LD/2,ST
U7980	0.5mm 20T Bevel Gear Shim - L1 EVO/R,ST,LD2
U8270	Driveshaft Assembled CVD V2 - LD,LD2 (pr)
U8271	CVD Rear Bone V2 - LD,LD2
U8395	2 Gear Diff Pin - LD/2 L1/EVO/R
U8399	Outer Slipper Plate - L1R
U8433	Gear Diff Rebuild Kit - L1R
U8579	Slipper Lockout Layshaft - ST2
U8580	Slipper Lockout Hub - ST2
U8581	Slipper Lockout Washer - ST2
U8603	Driveshaft Assembled CVD Layback (pr) - LD3
U8618	Moulded Idler Gear - LD3
U8619	Alloy Wheel Hex 4mm (-2) (pr) - LD3
U8620	Alloy Layshaft - LD3
U8621	Layshaft Bolt - LD3
U8622	LH Lower Trans Housing Layback - LD3
U8623	RH Lower Trans Housing Layback - LD3
U8624	Alloy Motor Mount Layback - LD3
U8626	Finger Guard Layback - LD3
U8627	CVD Rear Bone 69.5 Layback (pr) - LD3
U8628	CVD Rear Axle Layback (pr) - LD3
U8630	Moulded Idler Gear Layback - LD3
U8631	Outer Slipper Plate - LD3
U8633	C/F Motor Plate - LD3
U8635	Gear Diff Mouldings - LD3
U8646	Gear Diff Complete - LD/2/3

Bearings & Balls

U2698	Ball Bearing - 5x10x4 Red Seal - (pr)
U2699	Ball Bearing - 10x15x4 Red Seal - (pr)
U3075	Ball Bearing - 4x8x3mm Red Seal - (pr)
U3136	Ball Bearing - 5x8x2.5 - Shield (pr)
U3855	Ball Bearing - 5x10x3 Open - (pr)
U4318	Ball Bearing - 5x10x3 Red Seal - (pr)
U8274	Ball Bearing 5x12x4 Red Seal (pr)

Big Bore Shocks & Springs

RI-29101	Ride Shock Air Remover - Long
U3667	Big Bore Shock; Rebuild Kit - Off Rd pk4
U3706	Rod End Ball + Socket pr - Cougar
U4110	Off Road Shock O Ring 1/8 Silicone Pk 8
U4371	Big Bore Shock Adjusting Collar (Black) - pr
U4451	Big Bore Shock Collar O-ring - pk4
U4702	Shock Seal Housing V2 - Big Bore pr Off Road
U7388	Alloy Med Shock Body pr - LD/2,L1/EVO/R
U7389	Alloy Long Shock Body pr - LD/2,L1/EVO/R,ST
U7431	Rod End Socket (Dia 5.5mm) (pk4)
U7625	Spring Hanger Low pr - LD/2,L1 EVO/R



PRO WITH 2WD Off-Road Buggy

Big Bore Shocks & Springs Cont...

- U7630 Shock Piston Support pr - LD/2,L1 EVO/R,ST
- U7632 Tapped Shock Shaft; Med pr - LD/2,L1 EVO/R
- U7728 M2.5x4 Button Screws (pk10)
- U8380 Moulded Shock Pistons and Bushes-L1R-16 pcs
- U8426 Tapped Shock Shaft; Long (+1.2mm) - L1R (pr)
- U8555 Moulded Shock Top (pr) - ST2
- U8652 Front Shock Set - LD3
- U8653 Rear Shock Set - LD3
- CR177 CORE RC Big Bore Spring Tuning Set; Med 7prs
- CR178 CORE RC Big Bore Spring Tuning Set; Long 7prs
- CR179 Big Bore Spring; Med White - 2.8 pr
- CR180 Big Bore Spring; Med Red - 3.1 pr
- CR181 Big Bore Spring; Med Green - 3.4 pr
- CR182 Big Bore Spring; Med Blue - 3.7 pr
- CR183 Big Bore Spring; Med Black - 4.0 pr
- CR184 Big Bore Spring; Long White - 1.8 pr
- CR185 Big Bore Spring; Long Red - 2.0 pr
- CR186 Big Bore Spring; Long Green - 2.2 pr
- CR187 Big Bore Spring; Long Blue - 2.4 pr
- CR188 Big Bore Spring; Long Black - 2.6 pr
- CR635 Big Bore Spring; Med Orange - 4.3 pr
- CR636 Big Bore Spring; Med Yellow - 4.6 pr
- CR699 Big Bore Spring; Long Orange - 2.8 pr
- CR700 Big Bore Spring; Long Yellow - 3.0 pr
- CR808 High Response Spring; Long Red - 2.0 lb/in (pr)
- CR809 High Response Spring; Long Green - 2.2 lb/in (pr)
- CR810 High Response Spring; Long Blue - 2.4 lb/in (pr)
- CR811 High Response Spring; Long Black - 2.6 lb/in (pr)
- CR812 High Response Spring Tuning Set Long 4prs

Hardware

- CR024 CORE RC - Serrated M4 Steel Wheel Nut pk4
- U1960 SPEED PACK - O Rings; Various
- U3021 SPEED PACK - M3x6 Csk Hd - (pk10)
- U3022 SPEED PACK - M3x8 Csk Hd - (pk10)
- U3023 SPEED PACK - M3x10 Csk Hd - (pk10)
- U3131 SPEED PACK Alloy Spacers - M3x7mm 0.5;1;2mm (pk18)
- U3753 SPEED PACK - M2.5x6 Button Hd pk8
- U3754 SPEED PACK - M2.5x10 Csk Hd pk8
- U4124 SPEED PACK - Shims 5 x 7 x 0.4mm - pk6
- U4210 SPEED PACK - Pinion Grub Screw Set pk10
- U4220 'O' Ring 9.0x1.0 (pk10)
- U4241 SPEED PACK - M3 Alloy Nyloc Nuts - Black - pk10
- U4314 SPEED PACK - Alloy Black M3 Washers - 18pc
- U4650 SPEED PACK - M3 Nyloc Nut Steel - Black (10pcs)
- U4662 SPEED PACK - M3x4 Grub Screw - Cone Point (10pcs)
- U4862 Black Alloy Washers 0.50mm (pk12)
- U7104 SPEED PACK - M3x8 Button Hd (pk10)
- U7105 SPEED PACK - M3x10 Button Hd (pk10)
- U7106 SPEED PACK - M3x12 Button Hd (pk10)
- U7107 SPEED PACK - M3x16 Button Hd (pk10)
- U7108 SPEED PACK - M3x20 Button Hd (pk10)
- U7112 SPEED PACK - M3x8 Cap Hd (pk10)
- U7122 SPEED PACK - M3x12 Csk Hd (pk10)
- U7123 SPEED PACK - M3x16 Csk Hd (pk10)
- U7124 SPEED PACK - M3x20 Csk Hd (pk10)
- U7329 SPEED PACK M2.5 x 6 CSK (pk4)
- U7610 SPEED PACK - M2.5x16 Cap Hd (pk10)
- U7611 SPEED PACK - M3x14 Button Hd (pk10)
- U7677 SPEED PACK - M2.5x8 Csk Hd (pk10)
- U7689 M3 Brass Inserts - pk10
- U7699 Foam Strips 40 x 6 x 2mm thk - pk20
- U7707 M3 Steel Washers (pk10)
- U7709 M3 Black Alloy Washers 0.75mm (pk10)
- U7710 M3 Black Alloy Washers 1.00mm (pk10)
- U7711 M3 Black Alloy Washers 2.00mm (pk10)
- U7712 M3 Black Alloy Washers 3.00mm (pk10)
- U7900 SPEED PACK Needle Roller 1.5x9.8 (pk10)
- U8273 M4 Steel Nyloc Flanged Nut (4 pcs)
- U8275 Plastic Washer Set 1,1.5,2,3,4mm (20 pcs)
- U8536 M3x4 Grub Screw Cup Point - (pk10)

Option Parts

- AX009 Aerox Alloy Servo Arm - Short 25T Futaba
- AX010 Aerox Alloy Servo Arm - Short 23T KO/Sanwa
- CR035 CORE RC - Serrated Alloy M4 Nuts; Blue pk 4

Option Parts Cont...

- CR036 CORE RC - Serrated Alloy M4 Nuts; Violet pk 4
- CR196 CORE RC - Serrated Alloy M4 Nuts - Black - pk4
- CR280 Ti Pro Ball Studs - Short - (pr)
- CR282 Ti Pro Ball Studs - Long - (pr)
- CR304 Titanium Wheel Nuts M4 - pk4

- CR720 Ti Pro Ball Studs - Ultra Long - pk 2
- KRC-INSERTS Klinik RC M3 Thread Repair Inserts (10)
- KRC-M3REPAIR Klinik RC M3 Thread Repair Kit with Drill Bit (10)
- KRC-TBLD Klinik RC Cougar Laydown Ti Turnbuckle Set
- KRC-TBLD2 Klinik RC Cougar LD2 - Ti Turnbuckle Set
- U3348 Gear; CNC 80T Spur - Slipper
- U3386 Ceramic Bearing - 4x8x3 Shield - (pr)
- U3499 Roll Bar Blocks - pk4
- U3670 Big Bore Piston; 2 Hole White 1.5 (pr)
- U3770 Big Bore Piston; 3 Hole White 1.5 Rounded (pr)
- U3790 Gear; CNC 76T Spur - Slipper
- U4226 Gear; CNC 71T Spur - Slipper
- U4299 Turnbuckle HT - 52mm - pr
- U4344 Ceramic Bearing - 5x8x2.5 Shield - (pr)
- U4508 Big Bore Pro Bush - Off Road
- U4701 Big Bore Piston - 3 Hole Black 1.6 Rounded (pr)
- U4726 Pro Ball Bearing - 5x10x3 Shield - (pr)
- U4890 Alloy Spring Seat - Off Road - pr
- U4946 Pro Ball Bearing 5 x 10 x 4 sealed - pr
- U4999 Front Brass Weight 20g - KD,KC,LD/2,ST
- U7084 Shock Top Ring (pr) - Cougar KD,KC,LD/2,ST,L1R
- U7085 Shock Top (pr) - Cougar KD,KC,LD/2,ST,L1R
- U7086 Big Bore Piston - 2 Hole Black 1.60 (pr)
- U7087 Big Bore Piston - 2 Hole Red 1.70 (pr)
- U7090 SPEED PACK - M4x20 Grub Screw (pk4)
- U7318 Titanium Turnbuckle - 53mm - Silver - pr
- U7319 Titanium Turnbuckle - 60mm - Silver - pr
- U7398 Alloy Wheel Hex 6mm (0) pr - LD/2,L1/EVO/R,ST
- U7400 Titanium Low Profile M4 Serrated Nut (pk4)
- U7402 Alloy Wheel Hex 6.75mm (+.75) pr LD/2,L1/EVO/R,ST
- U7404 Alloy Radius Arms pr - L1/EVO/R,LD2
- U7433 Big Bore Piston Blank Tapered pr-LD/2,L1/EVO/R,ST
- U7434 Alloy Med Shock Body Kashima pr-LD/2,L1/EVO/R
- U7435 Alloy Long Shock Body Kashima pr-LD/2,L1/EVO/R,ST
- U7616 78T 2,3,4 Plate Slipper Spur Gear CNC
- U7624 Diff Cross Pin - LD/2,L1 EVO,ST,FT
- U7631 Piston; 3 hole - 13mm - Red pr - LD/2,ST
- U7646 Alloy Wheel Hex 5.25mm (-.75) pr LD/2,L1/EVO/R,ST
- U7651 Alloy Rear Link Mount V2 - LD/2,ST
- U7658 Rear Roll Bar Conversion - LD/2,ST
- U7659 ARB Mounting Collar - LD/2,L1 EVO/R,ST
- U7660 Rear Roll Bars 5pcs - LD/2,ST
- U7664 Brass Rear Weight (15g) pr - LD/2,ST
- U7665 Brass FR Strap (12g) - LD/2,ST
- U7673 Titanium Turnbuckle - 56mm - Silver - (pr)
- U7674 Titanium Turnbuckle - 76mm - Silver - (pr)
- U7678 Brass Radio Plate (30g) - LD/2,ST
- U7725 Pro-Ball Bearing 10x15x4 Sealed - (pr)
- U7730 Pro-Ball Bearing 4x8x3 Sealed - (pr)
- U7839 C/F LiPo Swivel pr - Mi7,FT,Mi8,FT8
- U7856 Turnbuckle Adjuster HTT - 71mm (pr)
- U7857 Titanium Turnbuckle - 71mm - Silver (pr)
- U7868 C/F Left Hand Lower Trans - LD/2,ST
- U7869 C/F Right Hand Lower Trans - LD/2,ST
- U7975 Alloy Eccentric Mid - pr KC,KD,LD/2,L1/EVO/R,ST
- U7976 Alloy Eccentric Hi-Lo - pr KC,KD,LD/2,L1/EVO/R,ST
- U7982 Alloy Spring Seat High - Off Road (pr)
- U8196 Servo Saver Mouldings - LD2
- U8197 Servo Saver Kit - LD2
- U8205 Alloy Centre Track Rod v2 - LD2
- U8207 Alloy Pivot Block Spacers 0.5mm - LD2
- U8211 Alloy Pivot Block - LD2
- U8212 Brass Pivot Block - LD2
- U8215 Front Roll Bar Wires (4) - LD2
- U8216 Front Roll Bar Kit - LD2
- U8334 Alloy LiPo Swivel - Mi8,L1R,FT8 (pr)
- U8381 Alloy Wing Mount - L1R
- U8389 Alloy Rear Hub Carriers (pr) - L1R
- U8396 Alloy Diff Complete V2 - KR,KD,LD/2,ST
- U8397 Alloy Diff Conversion V2 - KR,KD,LD/2,ST
- U8429 Alloy Wheel Hex 4.5mm (-1.5) pr - L1R
- U8438 Alloy Lipo Mounts Conversion - LD2 (pr)
- U8502 3 Plate Slipper Clutch Conversion - L1R
- U8543 Alloy Wheel Hex 7.5mm (+1.5) Black pr - ST2
- U8574 Alloy 5 Deg Yokes (pr) - ST2
- U8575 Alloy 2.5 Deg Yokes (pr) - ST2
- U8576 Alloy Front Hub Carriers (pr) - ST2
- U8578 Alloy 0.5mm Rear Strap Spacers - ST2
- U8585 Lockout 66T Spur Gear - ST, LD/2
- U8608 Front Wishbones Stiff (pr) - LD3
- U8638 Alloy Front Link Mount - LD3
- U8639 Ti Front Axle (pr) - LD3
- U8640 Front Wishbones Carbon Filled (pr) - LD3
- U8648 Rear Wishbones Carbon Filled (pr) - LD3
- U8649 Rear Wishbones Stiff (pr) - LD3
- U8650 C/F Front Shock Mount - LD3
- U8651 C/F Rear Shock Mount - LD3
- U8654 S2 Steering Arm A - LD3
- U8655 S2 Steering Arm B - LD3
- U8656 S2 Steering Arm C - LD3

OPTIONS PARTS



U4800 - Rear Roll Bar Ball (pk2)
U7031 - Socket Grey 8mm (pk4)
U7658 - Rear Roll Bar Conversion
U7659 - ARB Mounting Collar
U7660 - Rear Roll Bar Set (5pcs)

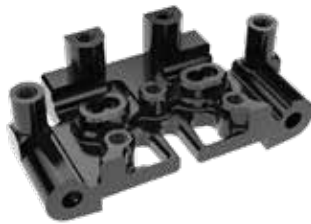

U8211 - Alloy Pivot Block (10g)



U8212 - Brass Pivot Block (41g)



U8207 - Alloy Pivot Block Spacers 0.5mm



U4890 - Alloy Spring Seat - Off Road - pr



AX009 - AEROX Alloy Servo Arm - Short 25t Futaba
AX010 - AEROX Alloy Servo Arm - Short 23t KO/SANWA



U7400 - Titanium Low Profile M4 Serrated Nut

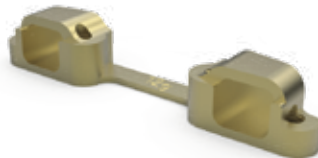

U7665 - Brass FR Strap (12g)



U8578 - Alloy 0.5mm Rear Strap Spacers - ST2



U8396 - Alloy Gear Diff Complete V2



U8216 - Front Roll Bar Kit - LD2



U8576 - Alloy Front Hub Carriers (pr) - ST2



U8205 - Alloy Centre Track Rod v2 - LD2



U8197 - Servo Saver Kit - LD2



U7839 - C/F LiPo Swivel pr - Mi7,FT,Mi8,FT8
U8334 - Alloy LiPo Swivel - Mi8,L1R,FT8 (pr)



U7975 - Alloy Eccentric Mid - (pr)
U7976 - Alloy Eccentric Hi-Lo - (pr)



U8574 - Alloy 5 Deg Yokes (pr) - ST2
U8575 - Alloy 2.5 Deg Yokes (pr) - ST2



U7404 - Alloy Radius Arms pr - L1/EVO/R,LD2

OPTIONS PARTS



U7678 - Brass Radio Plate (30g)



U8429 - Alloy Wheel Hex (-3.00) - (pr)
U7646 - Alloy Wheel Hex (-2.25) - (pr)
U7398 - Alloy Wheel Hex (-1.50) - (pr)
U7402 - Alloy Wheel Hex (-0.75) - (pr)
U8543 - Alloy Wheel Hex (0.00) - (pr)



U7434 - Alloy Med Shock Body Kashima Coat (pr)
U7435 - Alloy Long Shock Body Kashima Coat (pr)



U7651 - Alloy Rear Link Mount



U7868 - C/F Left Hand Lower Trans Housing
U7869 - C/F Right Hand Lower Trans Housing



U8389 - Alloy Rear Hub Carriers (pr)



U8381 - Alloy Wing Mount - L1R



U7624 - Diff Cross Pin - LD/2,L1 EVO,ST,FT
U8090 - Steel Diff Pins (pr)



U8438 - Alloy Lipo Mounts (pr)



U4999 - Front Brass Weight 20g - KD,KC,LD/2,ST

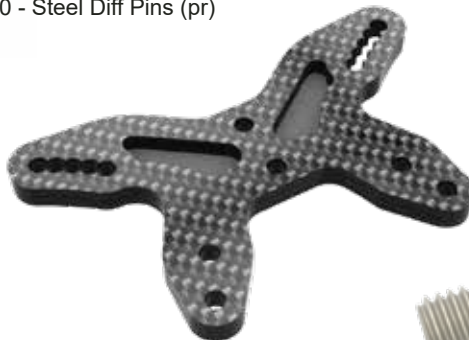

U8650 - C/F Front Shock Mount
U8651 - C/F Rear Shock Mount



U8639 - Ti Front Axle



U8640 - Front Wishbones Carbon Filled (pr)
U8608 - Front Wishbones Stiff (pr)
U8648 - Rear Wishbones Carbon Filled (pr)
U8649 - Rear Wishbones Stiff (pr)



U8638 - Alloy Front Link Mount



U7614 - Driveshaft Assembled UJ pr - LD/2
U8431 - Rear Driveshaft - L1R (pr)
U8606 - Driveshaft Assembled UJ Layback (pr) - LD3

Driver: _____ Date: _____ Event/Track: _____
 Qualify: _____ Final: _____ Best Lap: _____

TRACK TYPE

Grip Level High Medium Low

Type Tight Open Mixed

Condition Flat Bumpy Mixed

Surface Clay Long Astro Carpet
 Grass Short Astro Mixed

Weather _____

TYRES

	FRONT	REAR
Tyres	_____	_____
Wheels	_____	_____
Inserts	_____	_____

Notes: _____

Notes: _____

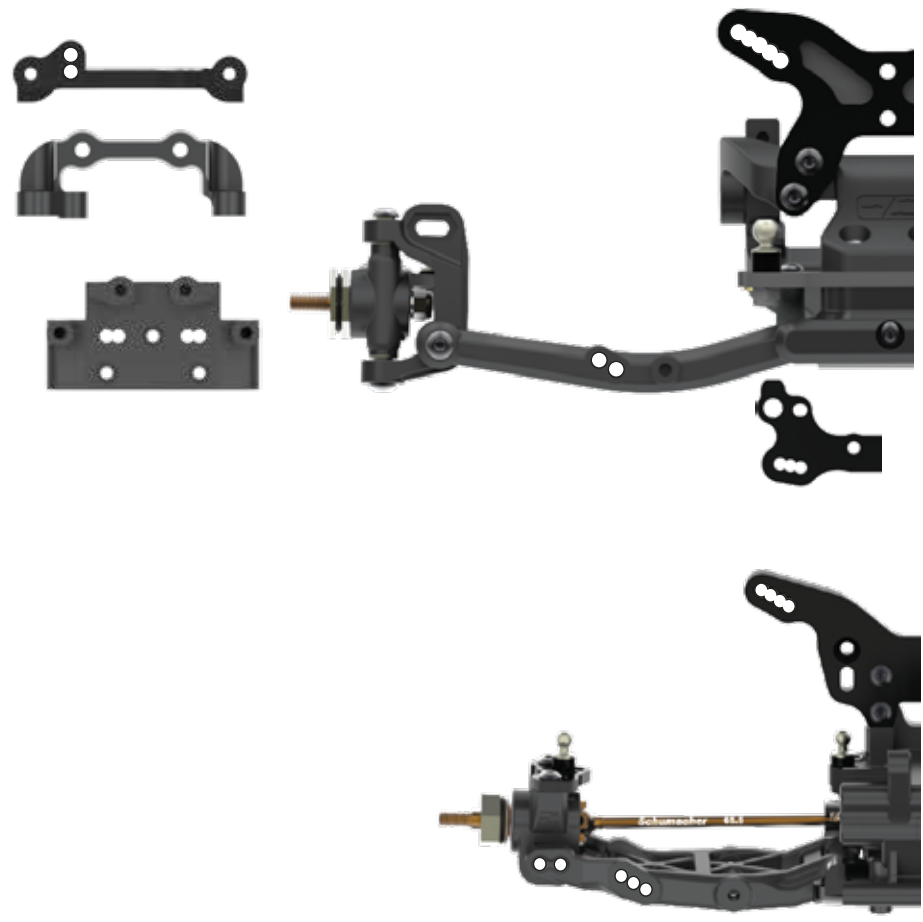

TRANSMISSION

Diff Height H M L

Diff Type B 2g 4g

Motor _____

Rotor Dia. _____ mm

Timing _____ deg

Pinion _____ t

Spur _____ t

Motor Plate A CF

Lock Out Y N

Slipper Plates 2 3

CHASSIS

Chassis A C/F

Chassis Insert _____

LiPo Position
 1 2 3 4 5 6 7 8

X Brace _____

Running Weight _____

Notes: _____

EQUIPMENT

E.S.C. _____

Servo _____

RX _____

LiPo _____

Bodyshell _____

WEIGHTS

Notes: _____

Driver: _____ Date: _____ Event/Track: _____
 Qualify: _____ Final: _____ Best Lap: _____

TRACK TYPE

Grip Level High Medium Low
 Type Tight Open Mixed
 Condition Flat Bumpy Mixed
 Surface Clay Long Astro Carpet
 Grass Short Astro Mixed
 Weather _____

TYRES

	FRONT	REAR
Tyres	_____	_____
Wheels	_____	_____
Inserts	_____	_____

Notes:

Notes:

FRONT SUSPENSION

KEY: P = Plastic, A = Alloy, B = Brass, CF = Carbon Fibre, S2 = Schumacher Composite, M = Medium, S = Stiff, Sh = Short, H = High, L = Low, F = Front, R = Rear, Y = Yes, N = No

Ride Height _____ mm
 Wheelbase 0 +1.5 +3.0 +4.5
 Toe _____ deg In Out
 Camber at Ride Height _____ deg
 Anti Roll Bar 0.9 1.0 1.1 1.2
 Front Wing Y N
 Bump Steer Washers _____ mm
 Pivot Block Height H M L
 Steering Arm Kit A B C

Notes:

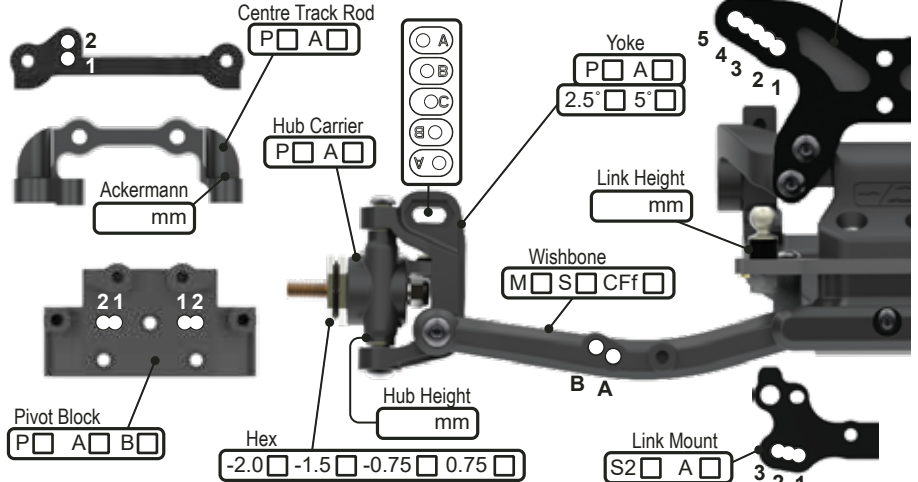

REAR SUSPENSION

KEY: P = Plastic, A = Alloy, B = Brass, CF = Carbon Fibre, S2 = Schumacher Composite, M = Medium, S = Stiff, Sh = Short, H = High, L = Low, F = Front, R = Rear, Y = Yes, N = No

Ride Height _____ mm
 Wheelbase 0 +2 +4 +6
 Anti-Squat 1° 2° 3° 4°
 Toe 4° 3.5° 3° 2.5° 2° 1.5° 1.0° 0.5°
 Camber at Ride Height _____ deg
 Anti Roll Bar 1.0 1.1 1.2 1.3 1.4
 Wing Gurney Height _____ mm
 Rearward Shock Position Y N
 Driveshaft Type CVD U/J
 Gearbox Type Laydown Layback

Notes:

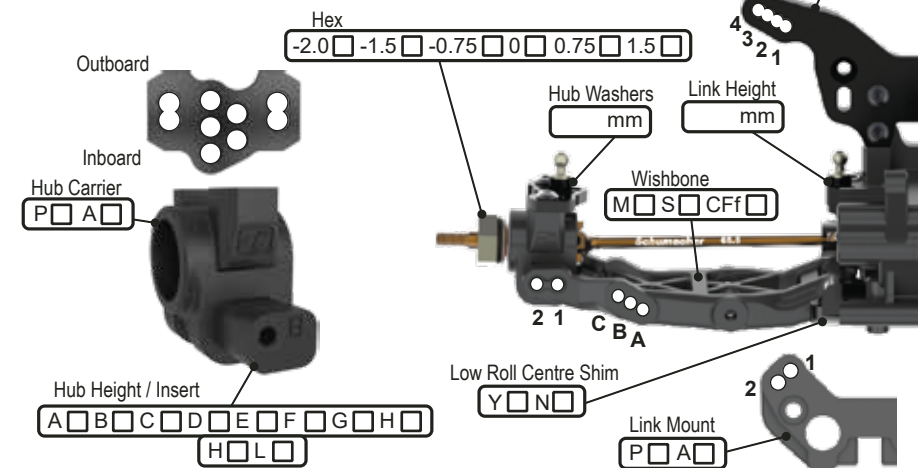

TRANSMISSION

B = Ball, 2g = 2 Gear, 4g = 4 Gear

Diff Height H M L
 Diff Oil _____ cSt
 Diff Type B 2g 4g
 Motor _____
 Rotor Dia. _____ mm
 Timing _____ deg
 Pinion _____ t
 Spur _____ t
 Motor Plate A CF
 Lock Out Y N
 Slipper Plates 2 3

CHASSIS

Chassis A C/F
 Chassis Insert 0mm +5mm
 LiPo Position
 1 2 3 4 5 6 7 8
 X Brace Y N
 Running Weight _____ g
 Radio Tray 1 2 3
 Notes:

EQUIPMENT

E.S.C. _____
 Servo _____
 RX _____
 LiPo _____
 Bodyshell _____

WEIGHTS

Chassis F R
 Rear Strap F R
 Radio Tray Y N
 Under LiPo Y N

SHOCKS

KEY: i = Internal, e = External, V = Vented, S = Sealed, A = Aeration

	FRONT	REAR
Cap	<input type="checkbox"/> V <input type="checkbox"/> S <input type="checkbox"/> A <input type="checkbox"/>	<input type="checkbox"/> V <input type="checkbox"/> S <input type="checkbox"/> A <input type="checkbox"/>
Body	_____	_____
Oil	_____ cSt	_____ cSt
Piston	_____	_____
Spring	_____ lb/in	_____ lb/in
Limiters (i)	_____ mm	_____ mm
Stroke	_____ mm	_____ mm
Limiters (e)	_____ mm	_____ mm

Notes:

