



T H E • U N F A I R • A D V A N T A G E

Instruction Manual v1.0



Schumacher Racing
71-73 Tenter Road
Moulton Park
Northampton
NN3 6AX
ENGLAND



www.racing-cars.com

Schumacher USA Inc
6302 Benjamin Road
Suite 404
Tampa
Florida 33634
U.S.A.

S1078

IMPORTANT SAFETY NOTES

- This product is not suitable for children under the age of 14, without the direct supervision of an adult.
- Select an area for assembly that is away from reach of very small children. The parts are small and can be swallowed by children causing choking and possible internal injuries.
- Exercise care when using any hand tools and sharp instruments during construction.
- Carefully read all manufacturers warnings and cautions for any parts used in the construction & use of your **m3**.



POINTS WHERE SHOCK OIL SHOULD BE APPLIED



POINTS WHERE AXLE GREASE SHOULD BE APPLIED
(It will reduce friction & assure smooth movement)



POINTS WHERE SILICONE GREASE SHOULD BE APPLIED

Do not use excessive force when tightening the selftapping screws, or you may strip the thread in the plastic. It is recommended to stop tightening it when the threaded part on the screw goes into the plastic part and you feel some resistance from the tightening.



Good



Over tighten and you may strip the thread in the plastic

In line with our policy of continuous development the exact specification of the kit may vary.

MISSING OR DEFECTIVE PARTS

In the unlikely event of any problems with your new kit you should contact the model shop where you purchased, quoting part number, bag number and batch

FOR BEST PERFORMANCE, IT IS VERY IMPORTANT THAT GREAT CARE IS TAKEN TO ENSURE THE FREE MOVEMENT OF ALL PARTS.

ADDITIONAL ITEMS REQUIRED EQUIPEMENTS NECESSAIRES ACCESORIOS ADICIONALES BENÖTIGTES ZUBEHÖR NÖDVÄNDIGA TILLBEHÖR ACCESSORI NECESSARI

TYRES AND INSERTS



BODYSHELL

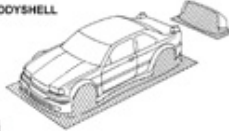

TRANSMITTER
ÉMETTEUR
EMISORA
FERNSTEUERSENDER MIT MINDESTENS 2-KANÄLEN
RADIOSTYRING MED MINST 2-KANALER
TRASMETTENTE 2 CANALI

8 PEN CELLS (FOR TRANSMITTER)
8 PILES POUR L'ÉMETTEUR
8 PILAS (PARA LA EMISORA)
8 MIGNON-ZELLEN FÜR SENDER
8 ST BATTERIER FOR SÄNDAREN
8 BATTERIE PER TRASMETTENTE

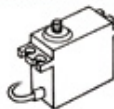

STEERING SERVO
SERVO DE DIRECTION
SERVO DE DIRECTION
LENKSERVO
SERVO FÖR STYRING
SERVOCOMANDO DELLO STERZO



RECEIVER
RECEPTEUR
RECEPTOR
EMPFÄNGER
MOTTAGARE
RICEVENTE

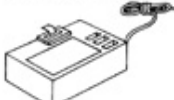

MOTOR & PINION
MOTEUR ET PIGNON
MOTOR Y PIGNON
MOTOR & MOTORHITZEL
ELMOTOR & PIGNON
MOTORE E PIGNONE



STICK BATTERY PACK (OPTION)



SADDLE BATTERY PACK



SPEED CONTROLLER
VARIATEUR ELECTRONIQUE
CONTROL DE VELOCIDAD
FAHRTENREGLER
ELEKTRONISKT FARTREGLAGE
VARIATORE ELETTRONICO DI VELOCITA

BATTERY CHARGER
CHARGEUR D'ACCUS
CARGADOR DE BATERIAS
LADGERÄT
LADGÅRE FOR ACKPÅKET
CARICABATTERIE

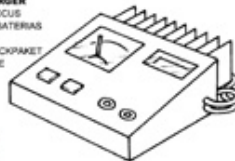

PAINT FOR BODYSHELL
BOIASE DE PEINTURE POUR LA CARROSSERIE
PINTURA CARROCCERIA
LEXANFÄRGEN FÜR DIE KAROSSERIE
LEXANFÄRÖ TILL KAROSSEN
VERNICE SPRAY PER POLICARBONATO



TOOLS REQUIRED



7mm AF SOCKET SPANNER
CLÉ DE 7mm À PIPE OU ERMANCHEE
LLAVE DE TUBO DE 7mm
STECKSCHLÜSSEL 7mm
7mm HYLINCKEL
CHAVE A TUBO DA 7mm



5.5mm AF SOCKET SPANNER
CLÉ DE 5.5mm À PIPE OU ERMANCHEE
LLAVE DE TUBO DE 5.5mm
STECKSCHLÜSSEL 5.5mm
5.5mm HYLINCKEL
CHAVE A TUBO DA 5.5mm



FLAT SCREWDRIVER
TOURNEVIS PLAT
AFORNILLADOR PLANO
SCHRAUBENZIEHER
SKRUMMEJSEL
CACCIAVITE A TAGLIO



6mm DRILL BIT
OUTIL DE FORAGE 6mm
BROCA DE 6mm
BOHRER 6mm
6mm BORR
PUNTA DA TRAPANO DA 6mm



SCISSORS
SCISSAUX
TUERAS
SCHERE
SAK
FORBICE

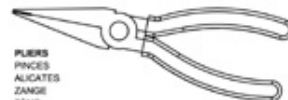

PLIERS
PINCES
ALCATES
ZANGE
TANG
PINZA A BECCHE SOTTILI



SCALPEL
CUTLER
CUCHILLA
SCHARPFES MESSER
HOBBYKNIV
CUTTER

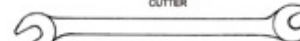

5.5mm AF SPANNER
CLÉ PLATE DE 5.5mm
LLAVE FLJA 5.5mm
GABELSCHLÜSSEL 5.5mm
5.5mm FAST NYCKEL
CHAVE INGLESE DA 5.5mm

RULER
MILLIMETRES

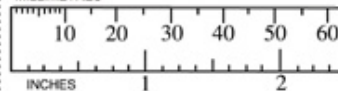

1
Lever Arm

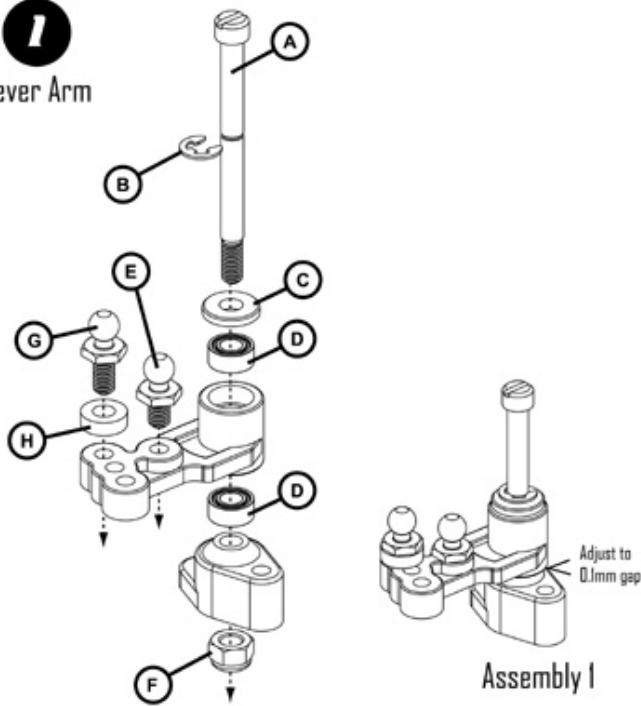

Assembly 1

2
Saver Arm

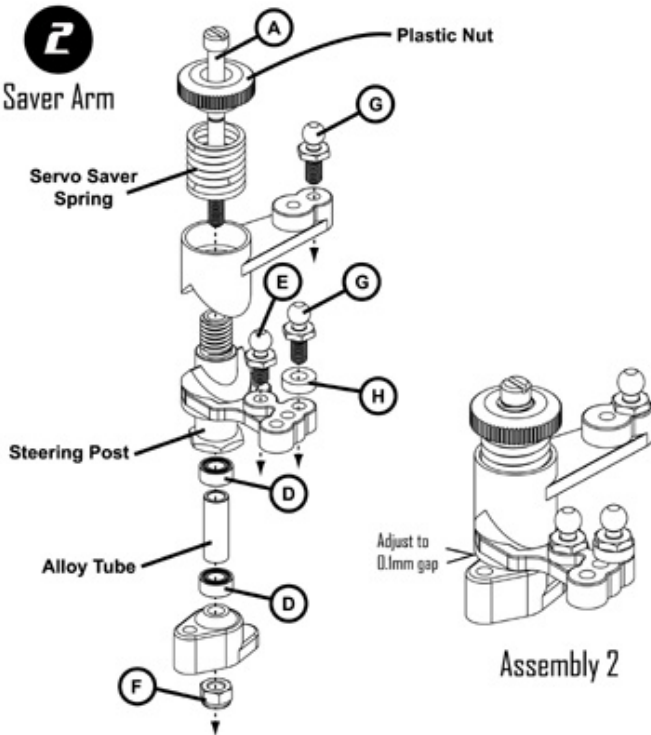

Assembly 2

Schumacher

mip

STEERING ASSEMBLY

Parts required:

- A**  Steering Post Long x 2
- B**  "E" Clip x 1
- C**  Stepped Washer x 1
- D**  1/8" x 1/4" Ball Race x 4
- E**  Ball Stud Ultra Short x 2
- F**  M3 Nylon Nut x 2
- G**  Ball Stud Short x 3
- H**  2mm Spacer x 2

TRACK TIP
Ensure that the steering posts are screwed in as vertically as possible (90°).

3

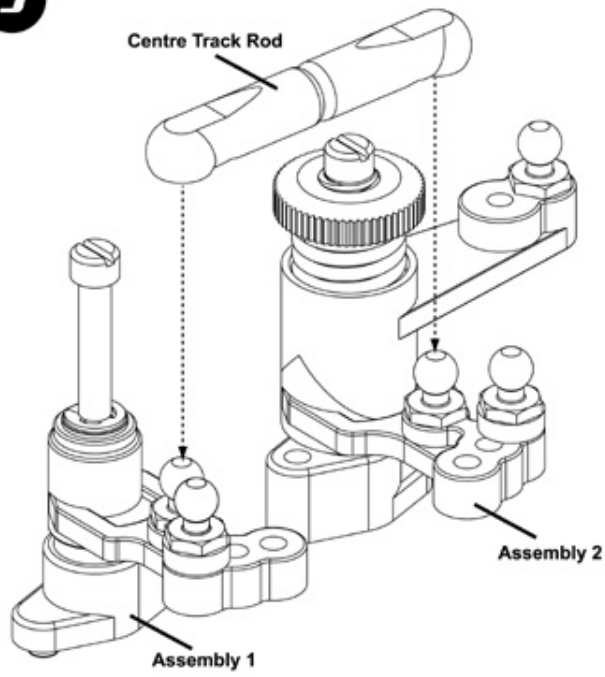

4

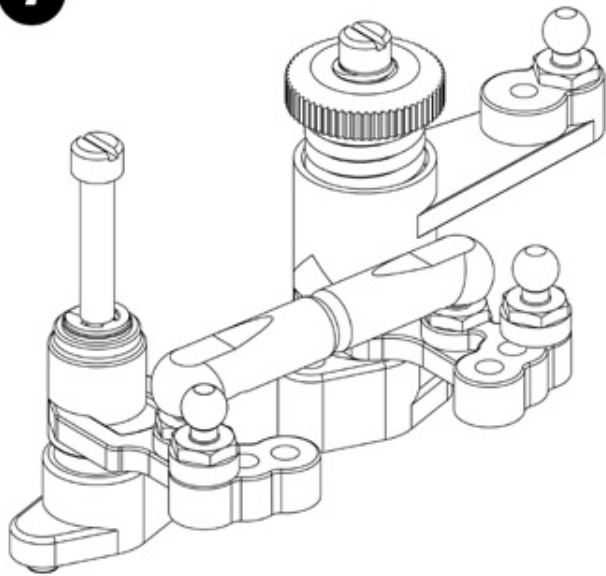

Final Assembly

2

Schumacher

MP

STEERING ASSEMBLY
Continued.

TRACK TIP
Ensure that the
steering rotates
easily.

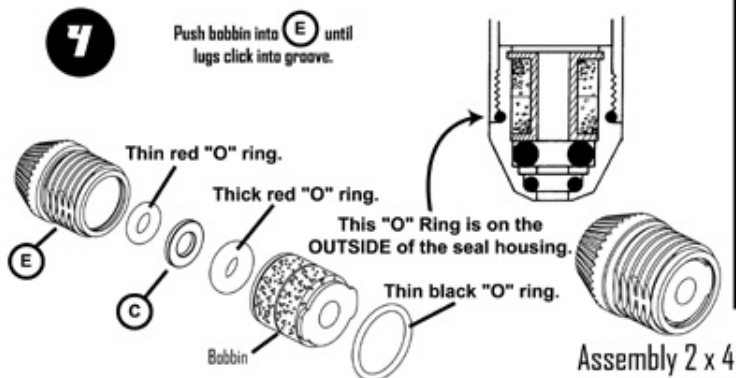
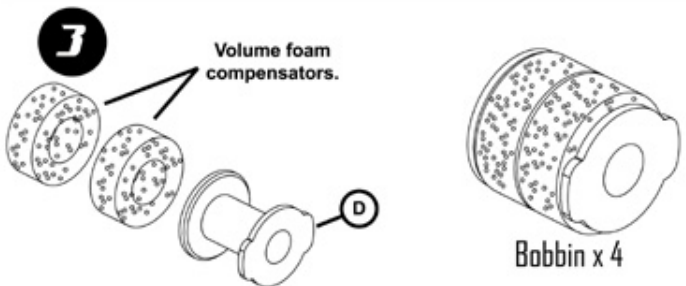
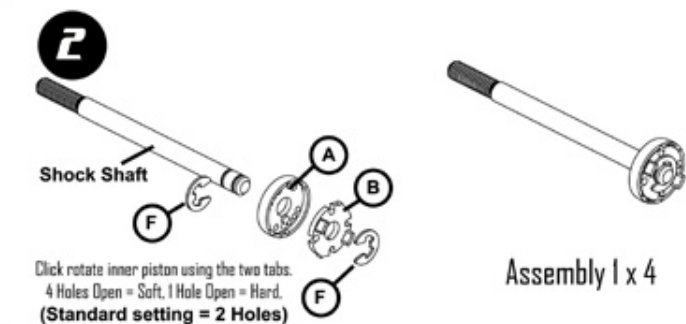
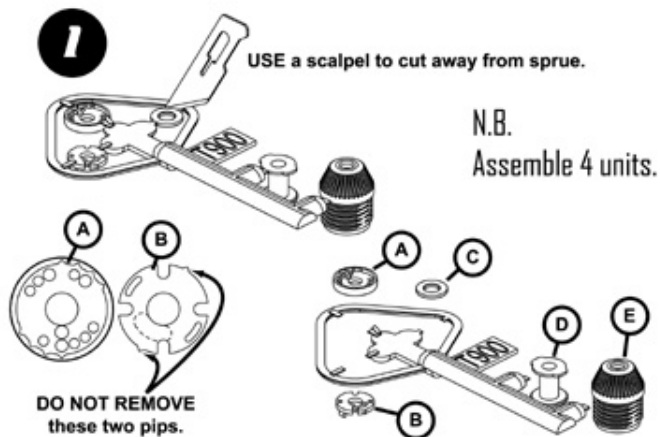

Schumacher

MIR

SHOCK ASSEMBLY
Parts required:

- (A) Outer Piston x 4
- (B) Inner Piston x 4
- (C) Spacer x 4
- (D) Bobbin x 4
- (E) Seal Housing x 4
- (F) "E" clip x 8

TRACK TIP

Soak the volume foam compensators in shock oil before assembly, this will help with air free shocks!

3

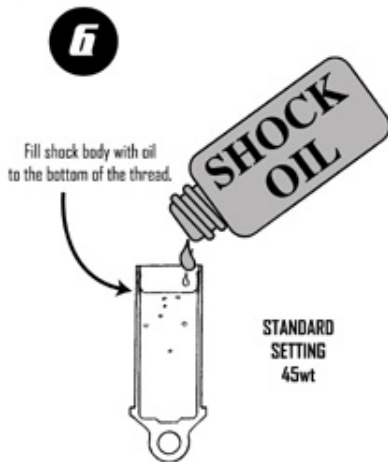

Make 4

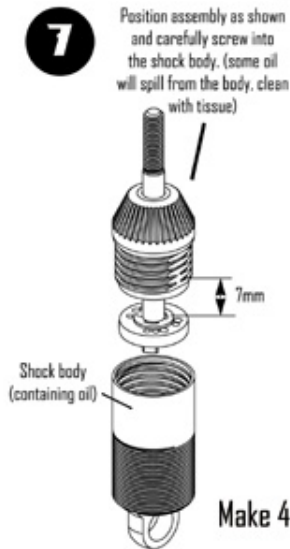

Make 4

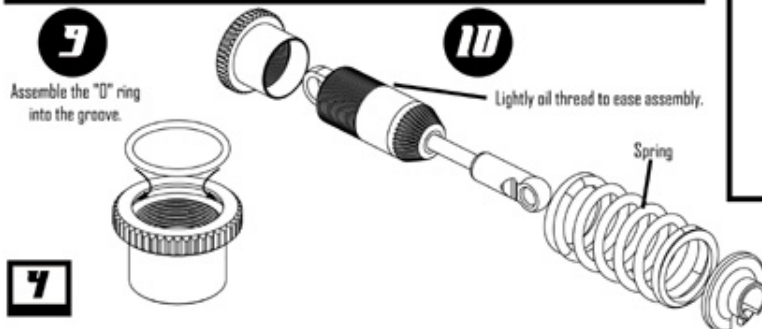
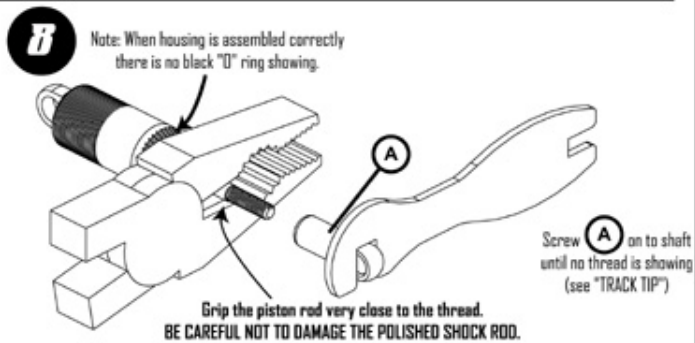

7

Schumacher

MIR

SHOCK ASSEMBLY
Continued.
Parts required:

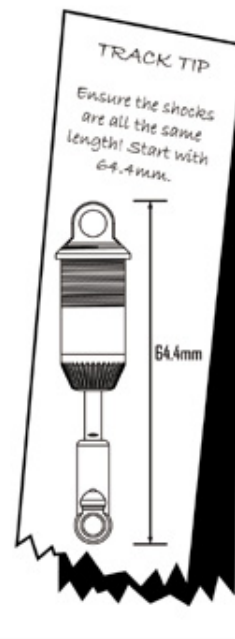

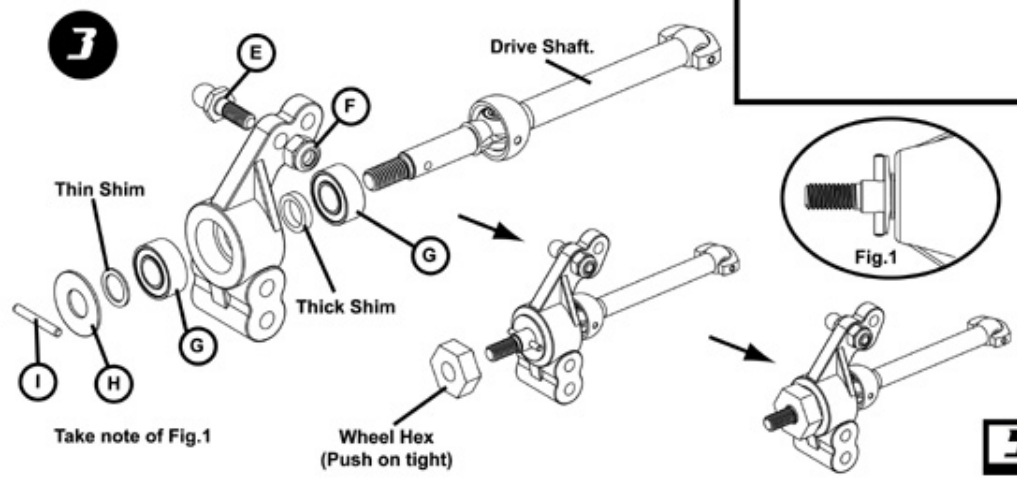
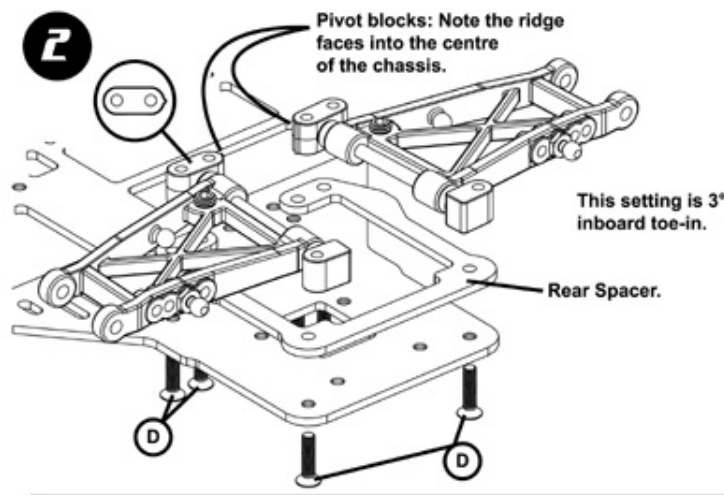
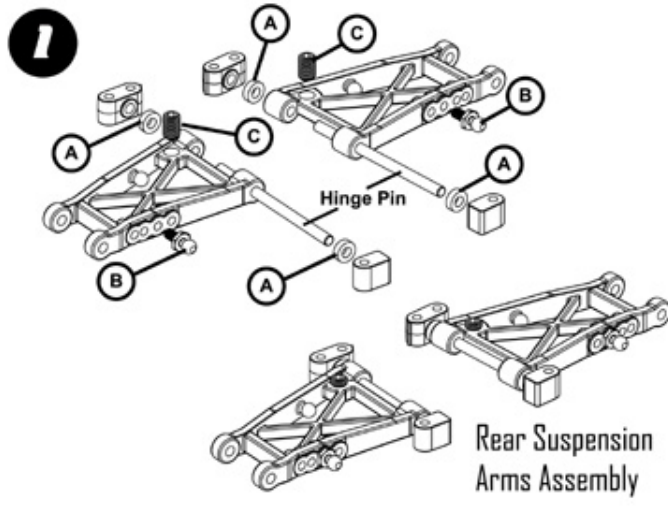

Schumacher

mi2

BAG 1 ASSEMBLY
Parts required:



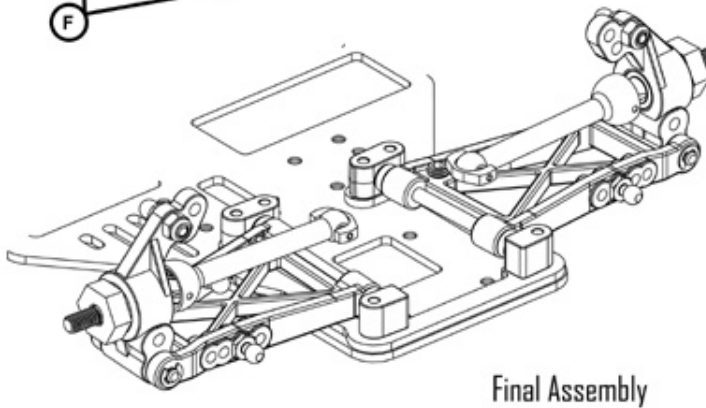
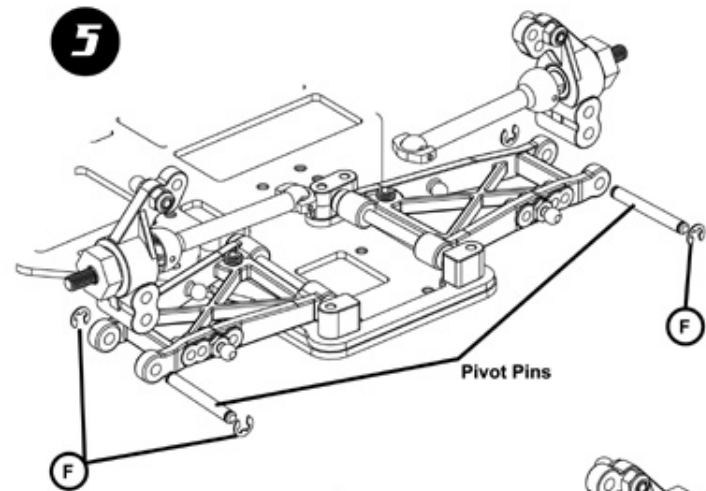
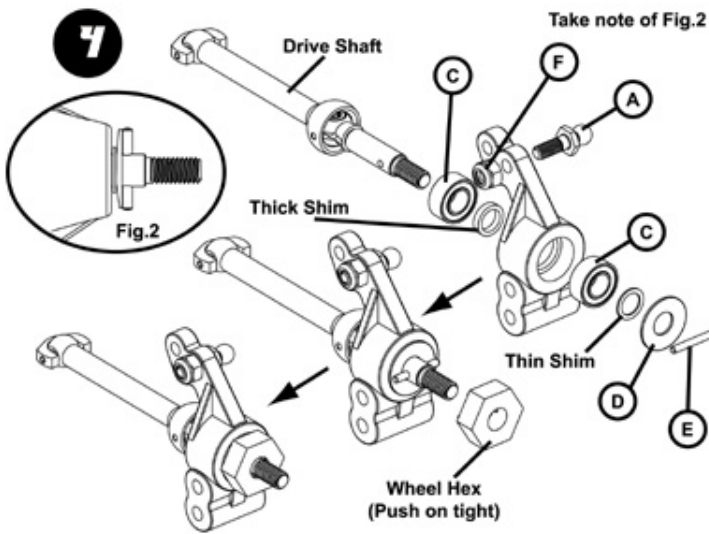



- A** 2mm Spacer x 4
- B** Ball Stud Short x 2
- C** M5 x 8mm Grub x 2
- D** M3 x 12mm TORX Csk x 6
- E** Ball Stud Long x 1
- F** M3 Nyloc Nut x 1
- G** 5 x 10mm Bearing x 2
- H** Disc Spring x 1
- I** 1.5mm x 11.8mm Needle Roller x 1



Schumacher

MIR

BAG 1 ASSEMBLY
Continued.
Parts required:



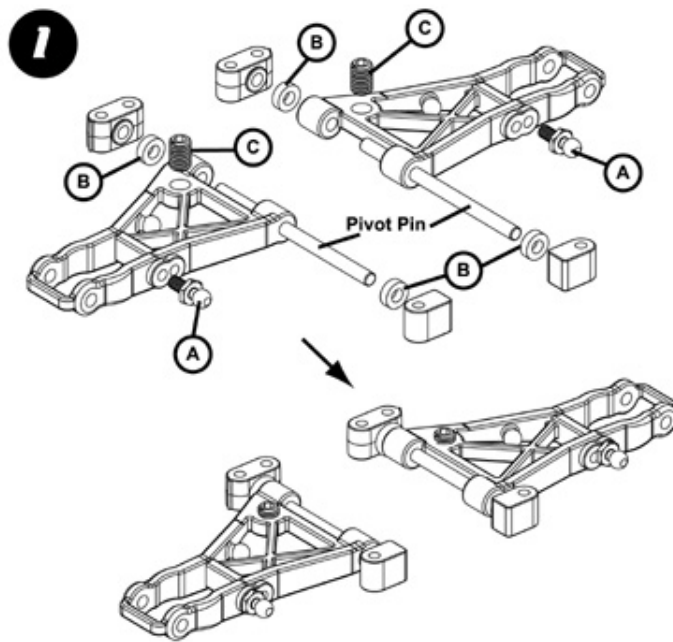

- A**  Ball Stud Long x 1
- B**  M3 Nyloc Nut x 1
- C**  5 x 10mm Bearing x 2
- D**  Disc Spring x 1
- E**  1.5mm x 11.8mm Needle Roller x 1
- F**  "E" Clip x 4



Schumacher

mi2

BAG 2 ASSEMBLY
Parts required:

- A**  Ball Stud Short x 2
- B**  2mm Spacer x 4
- C**  M5 x 8mm Grub x 2
- D**  M3 x 12mm TORX Csk x 6

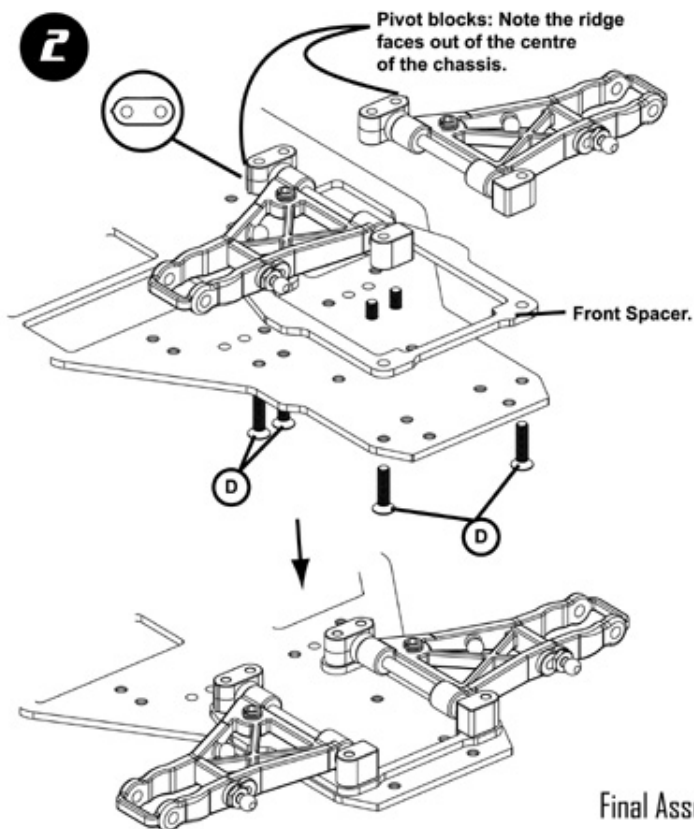

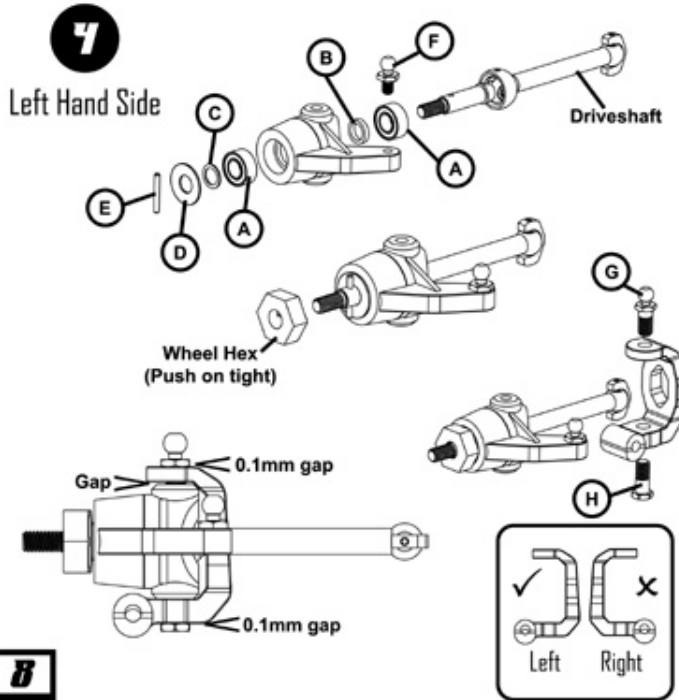
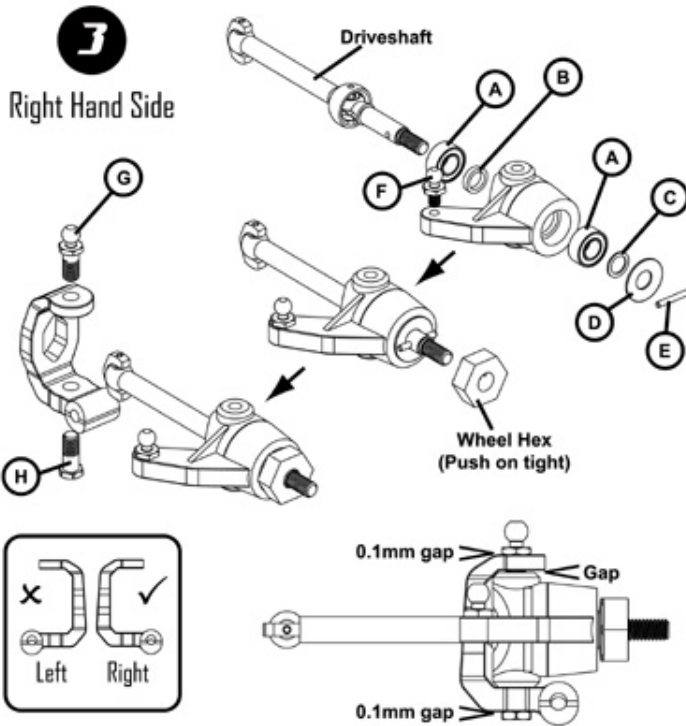

8

Schumacher

MIR

BAG 2 ASSEMBLY Cont.
Parts required:

- A** 5 x 10mm Bearing x 4
- B** Thick Shim x 2
- C** Thin Shim x 2
- D** Disc Spring x 2
- E** 1.5mm x 11.8mm Needle Roller x 2
- F** Ultra Ball Stud x 2
- G** 4mm Ball Pivot x 2
- H** 4mm Pivot x 2

TRACK TIP
Ensure free movement of the hub, in the yoke.

5

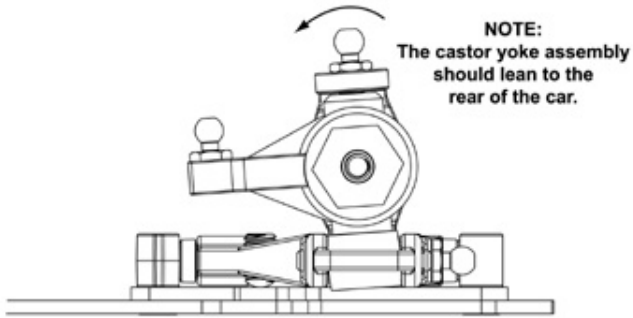
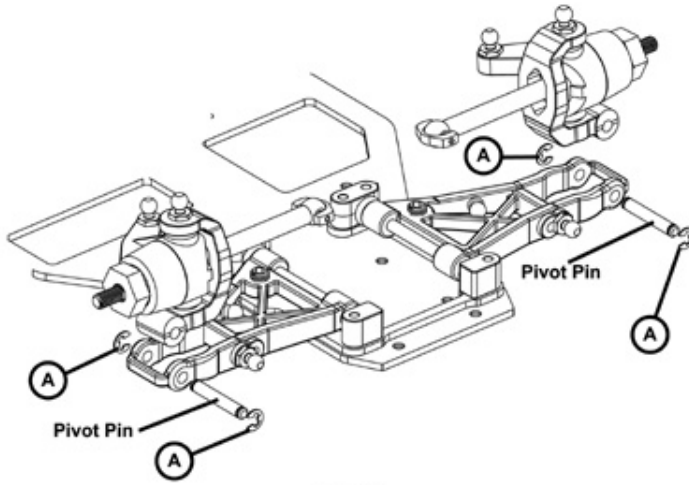

6

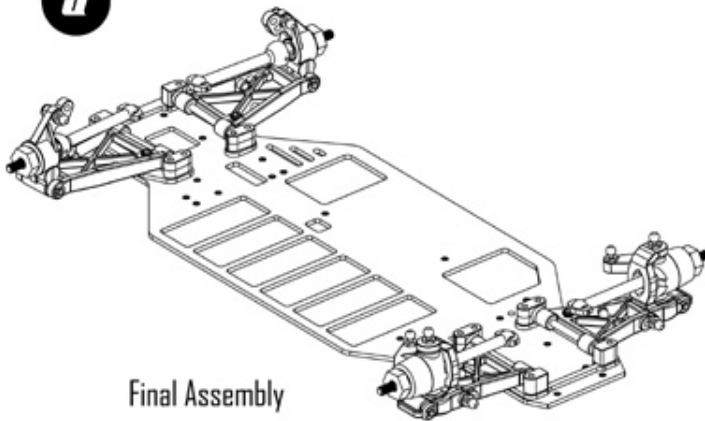

Final Assembly

Schumacher

MIR

BAG 2 ASSEMBLY Cont.

Parts required:

- A**  "E" Clip x 4

TRACK TIP
Ensure that the suspension arms pivot freely.

7

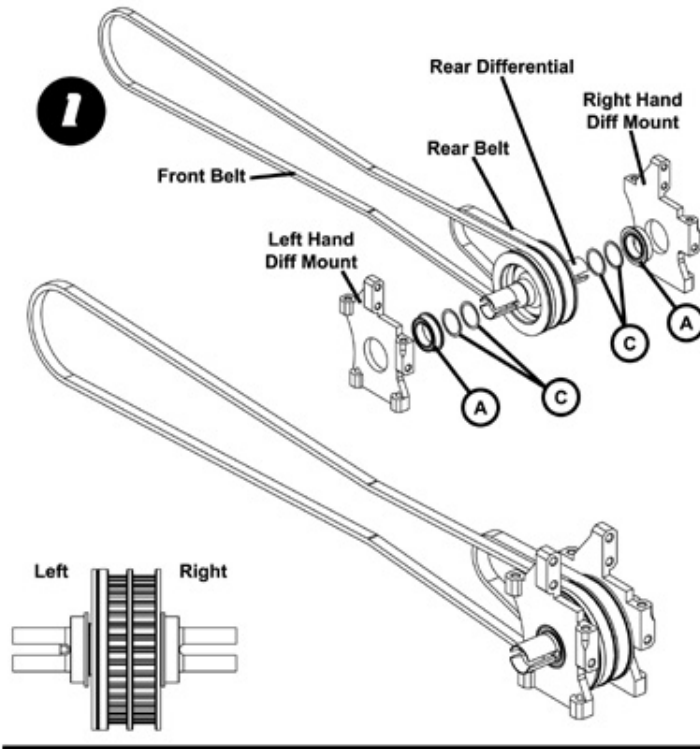



Schumacher

MIR

BAG 3 ASSEMBLY

Parts required:

- A**  10mm x 15mm Flanged Ball Bearing x 2
- B**  M3 x 8mm Csk TORX x 4
- C**  Diff Shim x 4

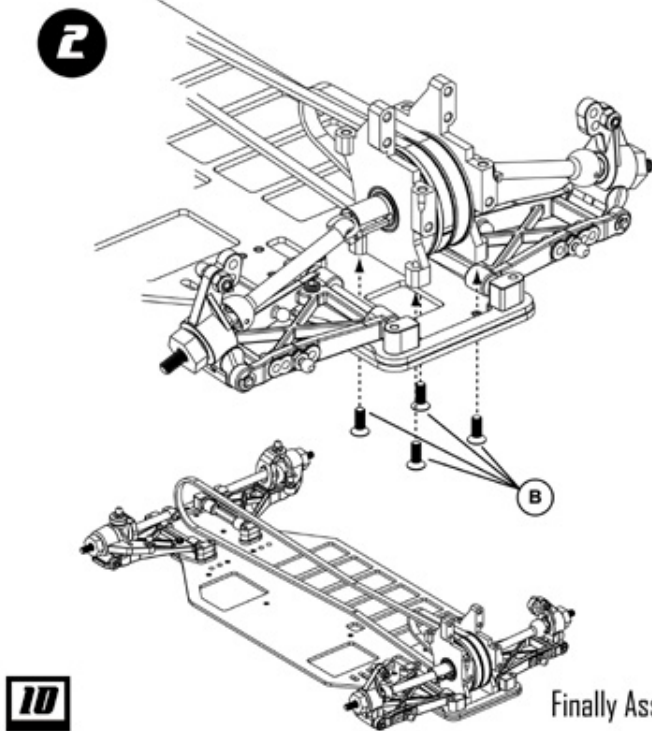

TRACK TIP

Ensure that the belts are not kinked or trapped and are free to rotate the differential.

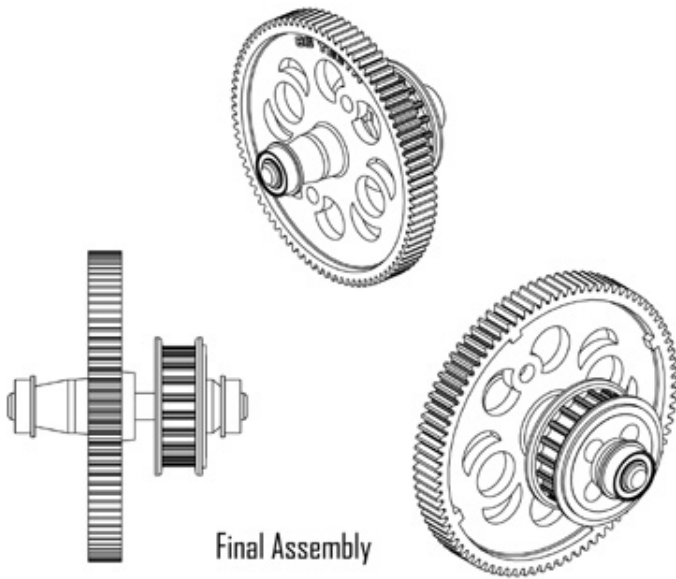
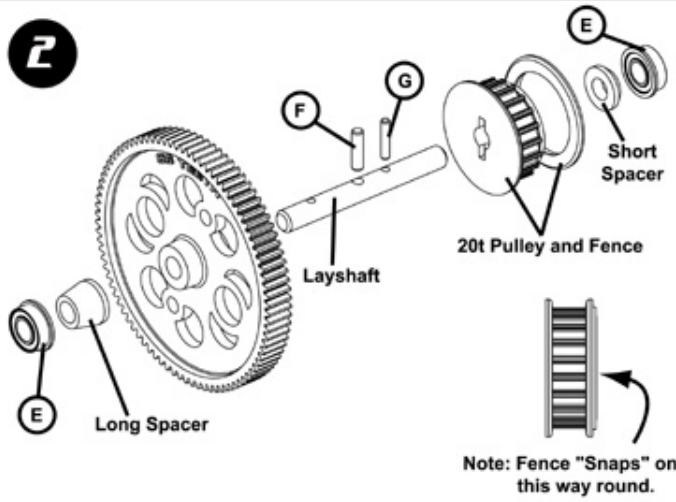
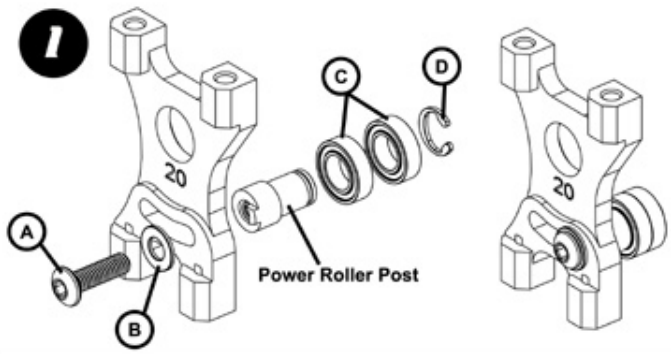

Schumacher

MIR

BAG 4 ASSEMBLY
Parts required:

- A** M3 x 10 Button Head x 1
- B** M3 Steel Washer x 1
- C** 5 x 8 x 2.5 Ball Race x 2
- D** "C" Clip x 1
- E** 4mm x 8mm Flanged Ball Race x 2
- F** 2mm x 7.8mm Needle Roller
- G** 1.5mm x 7.8mm Needle Roller

11

3

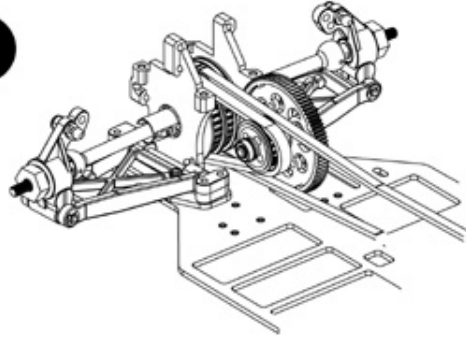

7

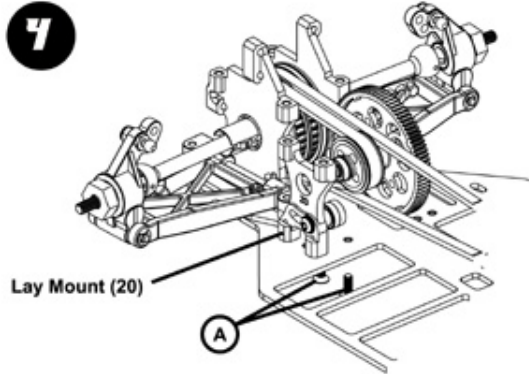

Lay Mount (20)

A

5

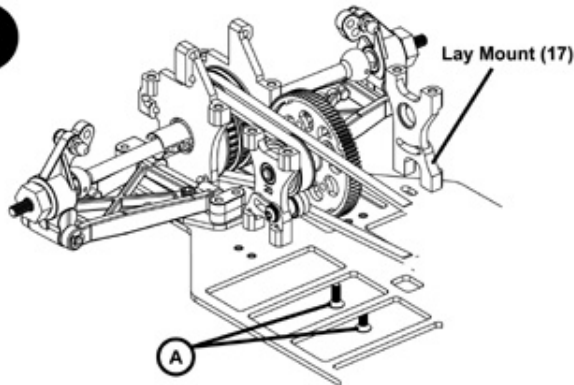

Lay Mount (17)

A

6

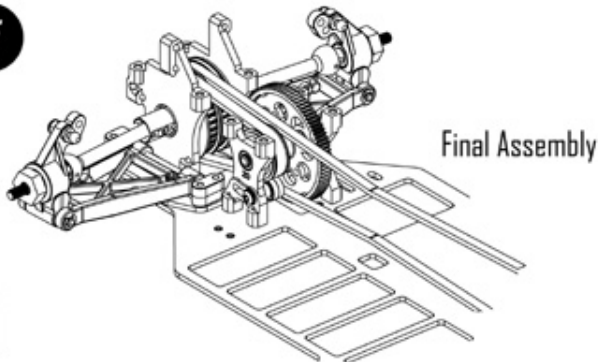

Final Assembly

12

Schumacher

MI2

BAG 4 ASSEMBLY Cont.

Parts required:

A



M3 x 8 Csk TORX x 4

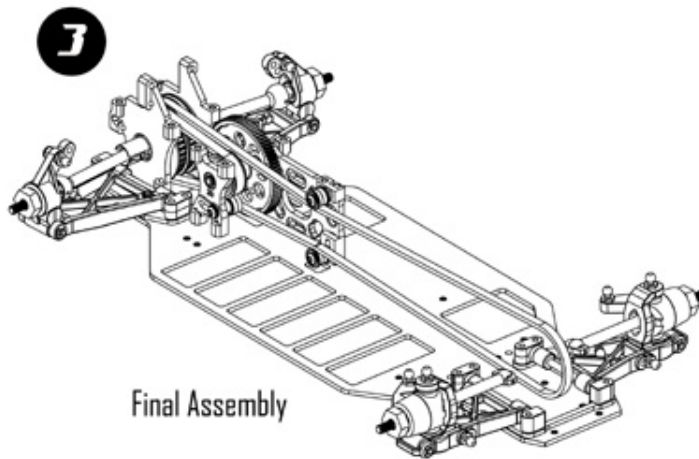
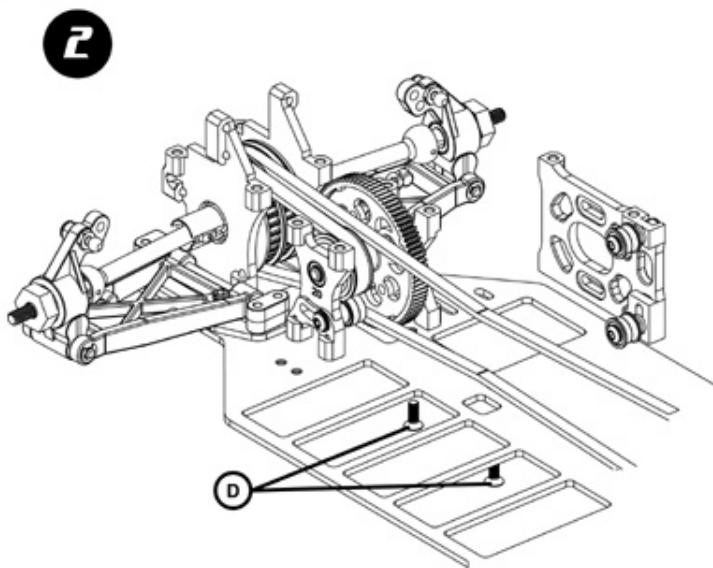
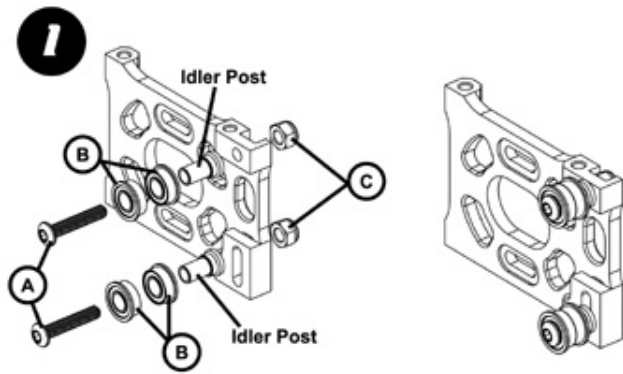

Schumacher

MIR

BAG 5 ASSEMBLY

Parts required:

- A**  M3 x 16 Button Head x 2
- B**  4mm x 8mm Flanged Ball Race x 4
- C**  M3 Nylon Nut x 2
- D**  M3 x 8 Csk TORX Head x 2

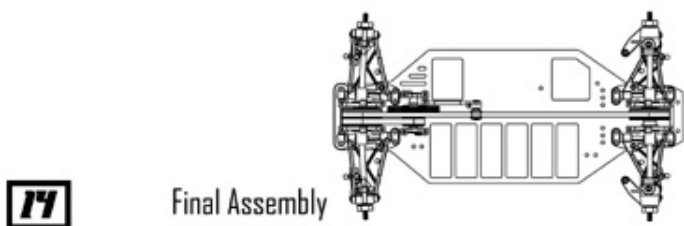
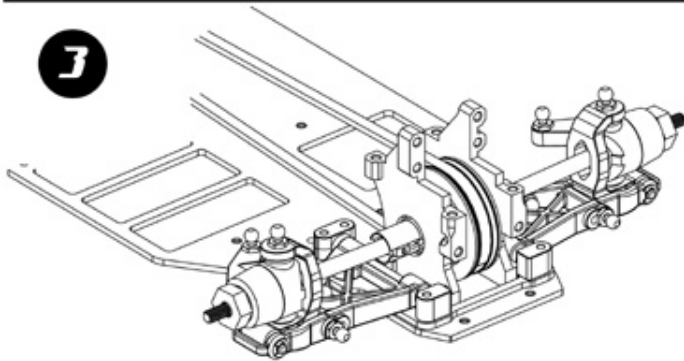
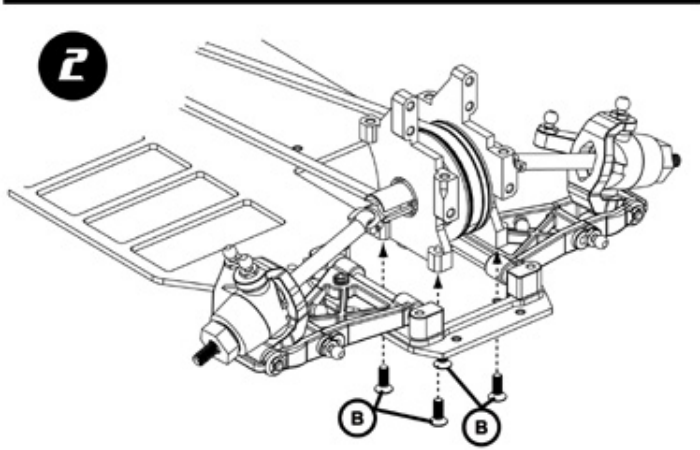
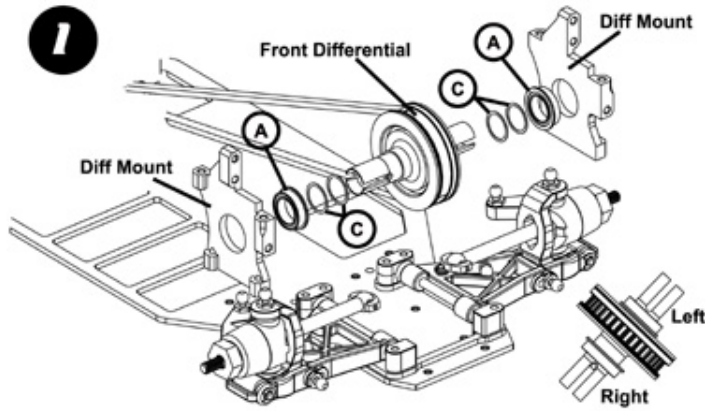

17

Final Assembly

Schumacher

MIR

BAG 6 ASSEMBLY
Parts required:

- A**  10mm x 15mm Flanged Ball Bearing x 2
- B**  M3 x 8mm Csk TORX x 4
- C**  Diff Shim x 4

1

Steering Assembly
(from page 2)

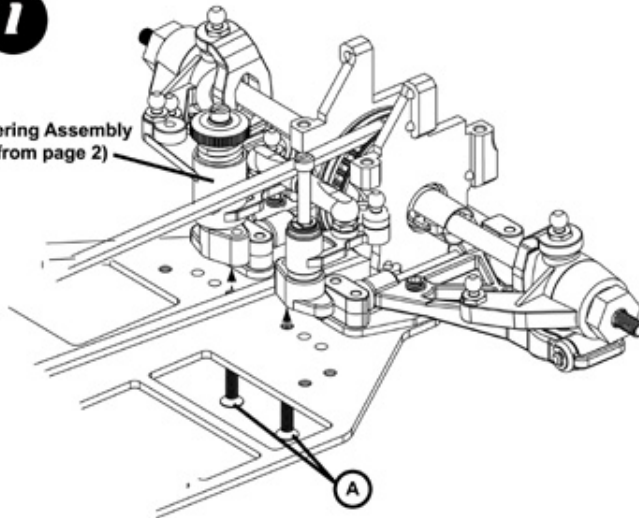

2

Track Rod (Make 2)

Ball Grippa

24mm Turnbuckle

Ball Grippa

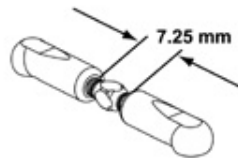

3

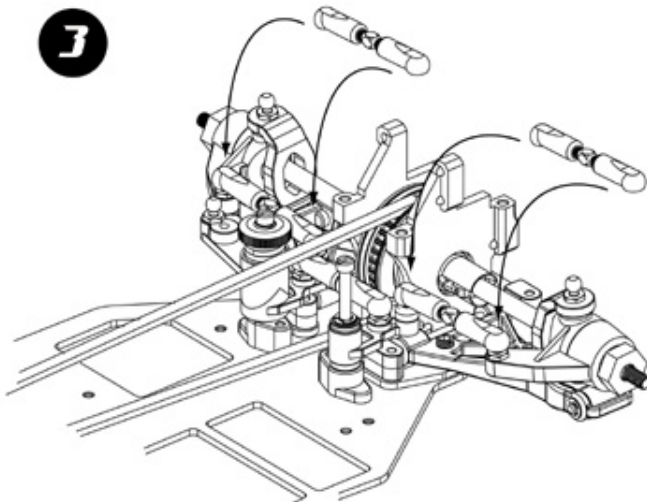

Schumacher

mi2

BAG 7 ASSEMBLY
Parts required:



M3 x 10mm Cok TORX x 2

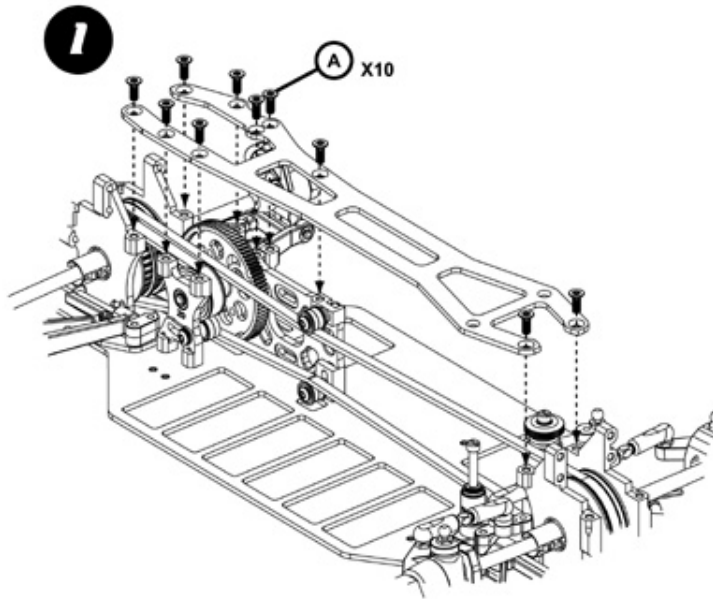

Schumacher

mi2

BAG 8 ASSEMBLY
Parts required:

A  M3 x 8mm Csk TORX x 10

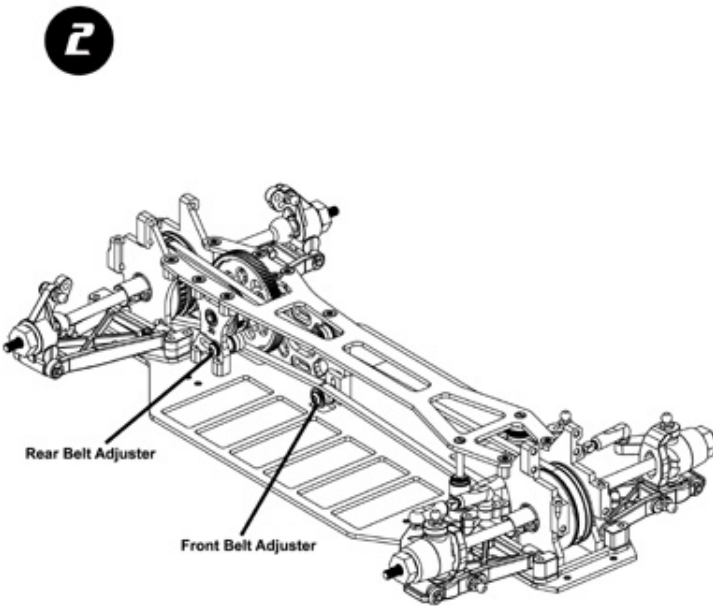

TRACK TIP
Adjust belt tension so that the belts run freely, but do not skip.

Finally Assembly

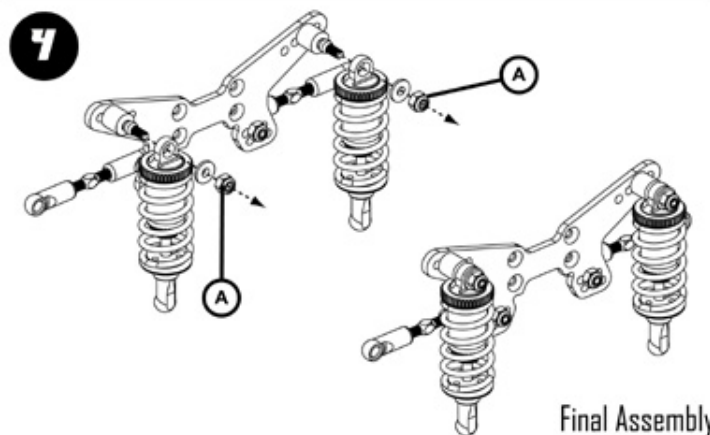
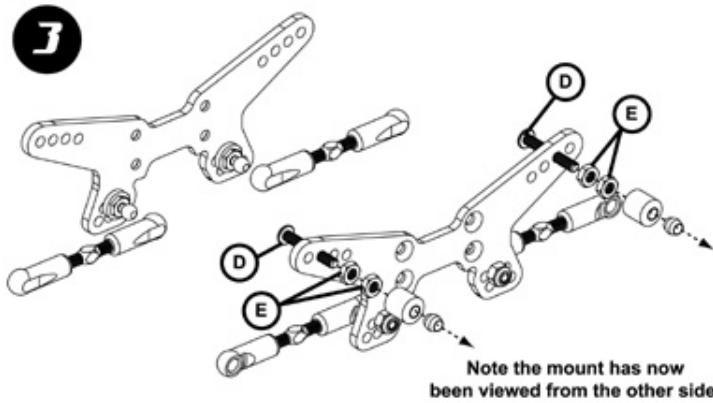
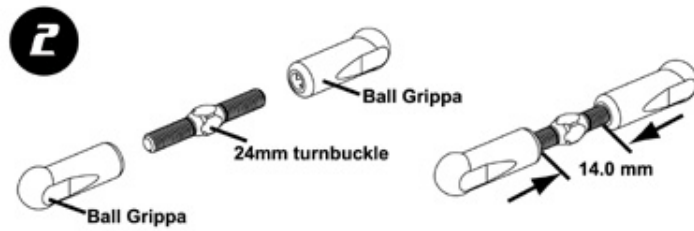
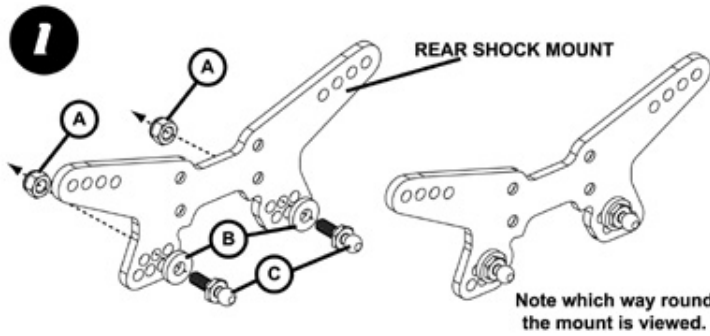

Schumacher

mi2

BAG 9 ASSEMBLY
Parts required:

- A** M3 Nylon Nut x 4
- B** 1.6mm Nylon Washer x 2
- C** Ball Stud Long M3 x 2
- D** M3 x 20 Button Head x 2
- E** M3 Nut x 4

TRACK TIP
Put all the left hand threaded turnbuckles on the left of the car. This makes it easier when adjusting the lengths on the car, as you turn the link the same way!

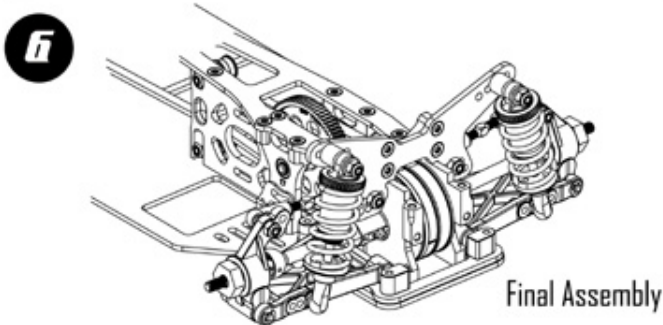
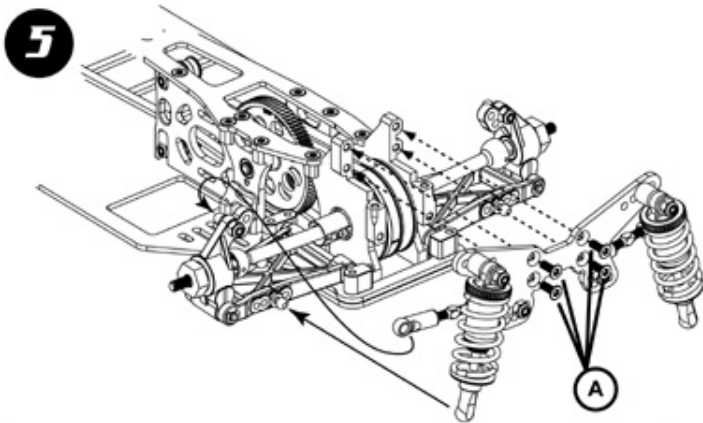

Schumacher

MIR

BAG 9 Continued.
Parts required:

- (A)  M3 x 8 Csk TORX x 4

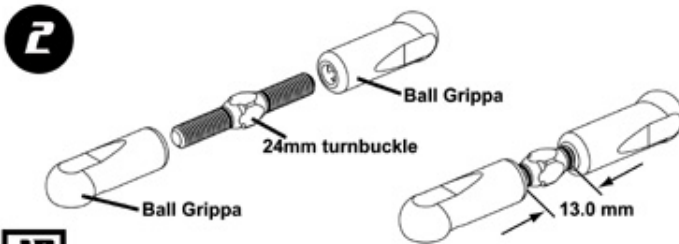
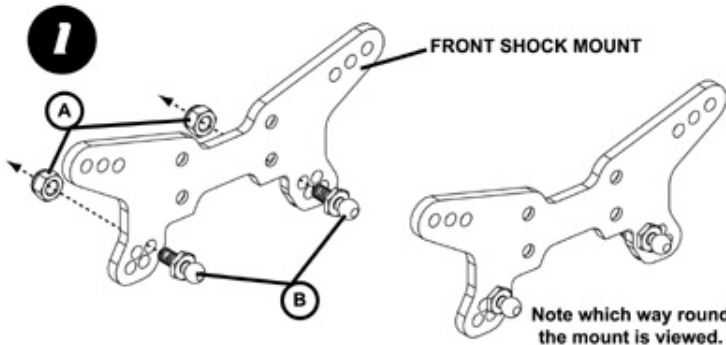

18

Schumacher

MIR

BAG 10 ASSEMBLY
Parts required:

- (A)  M3 Nylac Nut x 2
- (B)  Ball Stud Short x 2

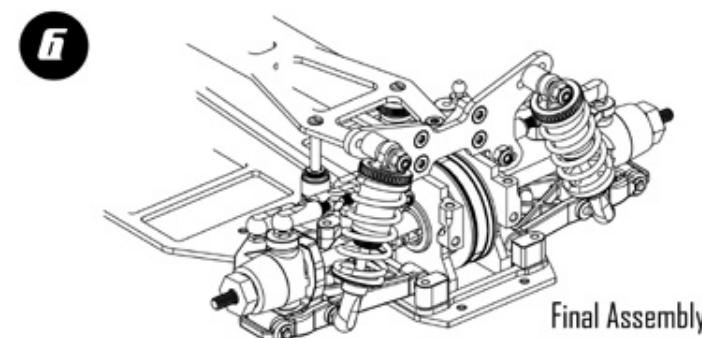
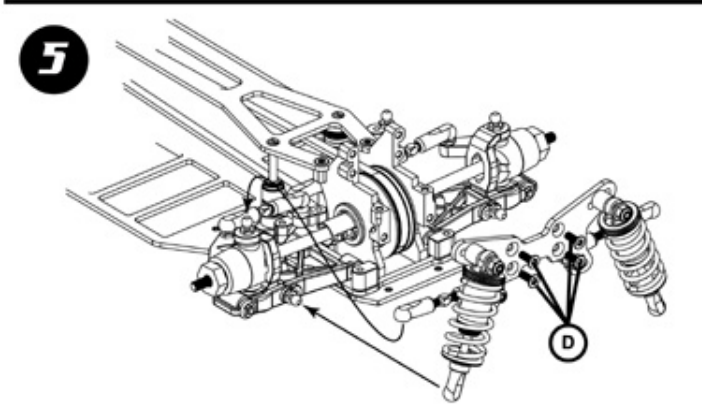
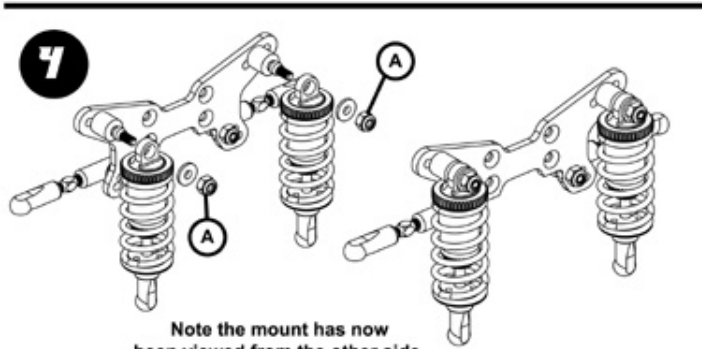
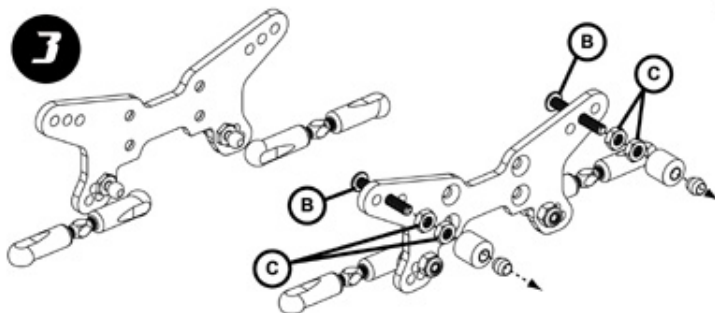

Final Assembly

Schumacher

MIR

BAG 10 ASSEMBLY
Continued.

- A**  M3 Nylon Nut x 2
- B**  M3 x 20 Button Head x 2
- C**  M3 Nut x 4
- D**  M3 x 8 Csk TORX x 4

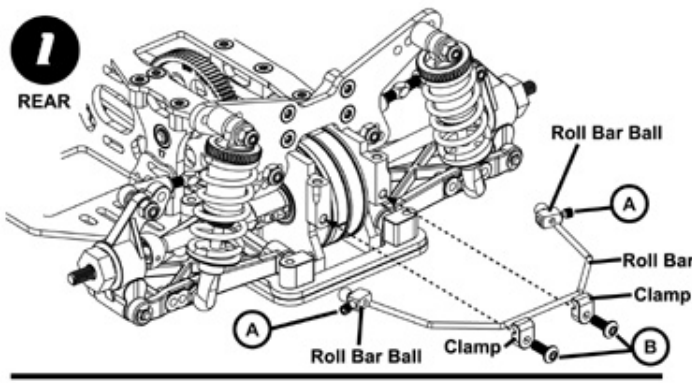

Schumacher

MIR

ROLL BARS
Parts required:

A M3 x 3 Grub Screw x 4

B M3 x 8 Button Head x 4

NOTE: The REAR roll bar is the bigger of the two.

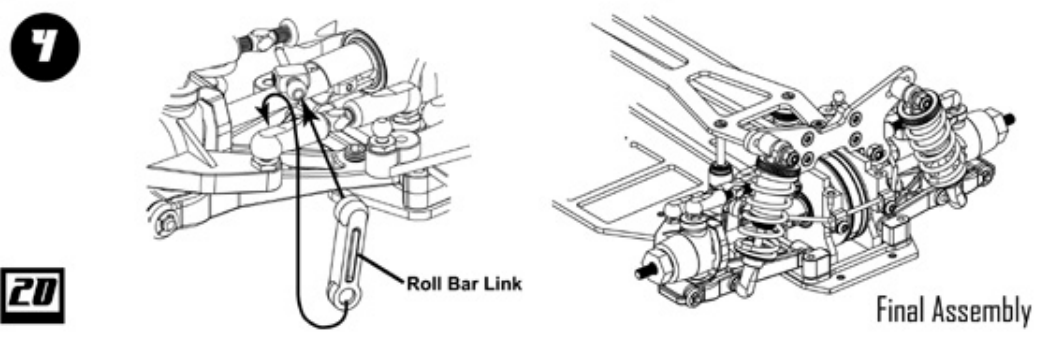
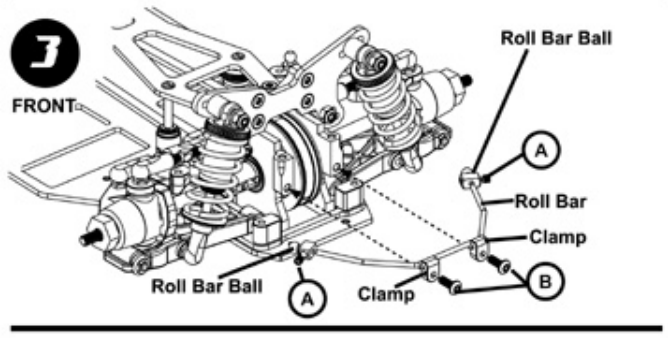
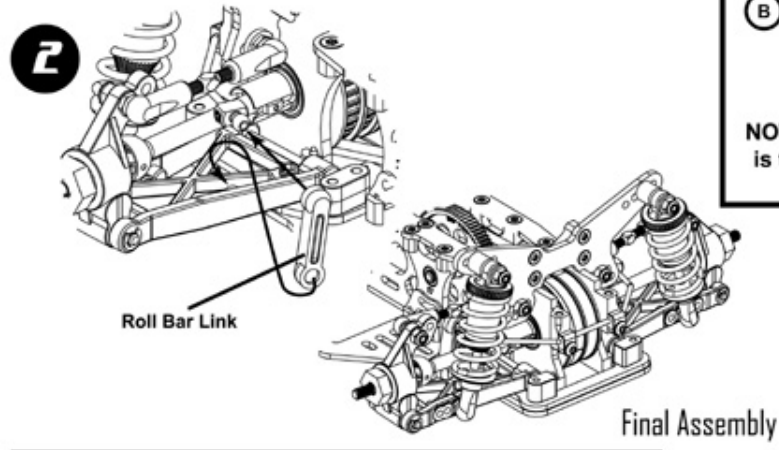



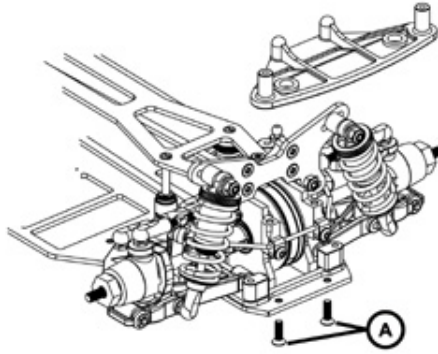

1
FRONT



Schumacher

mi2

BODY MOUNTS
Parts required:

- A**  M3 x 12 TORX Csk x 2
- B**  M3 x 16 TORX Csk x 2
- C**  M3 x 10 TORX Csk x 4
- D**  M4 x 6 Grub Screw x 4
- E**  "R" Clip x 4

2

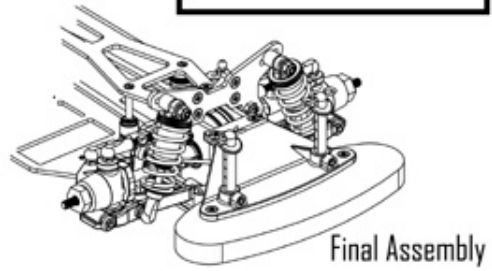
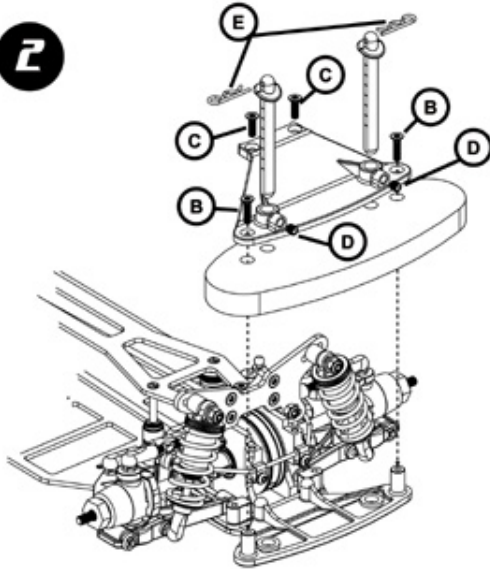

3
REAR

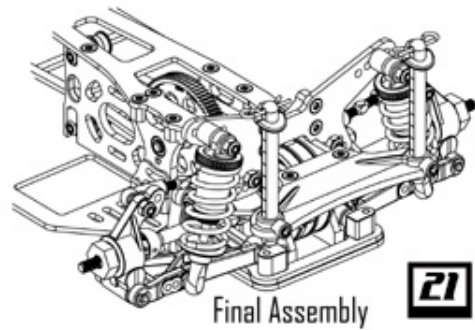
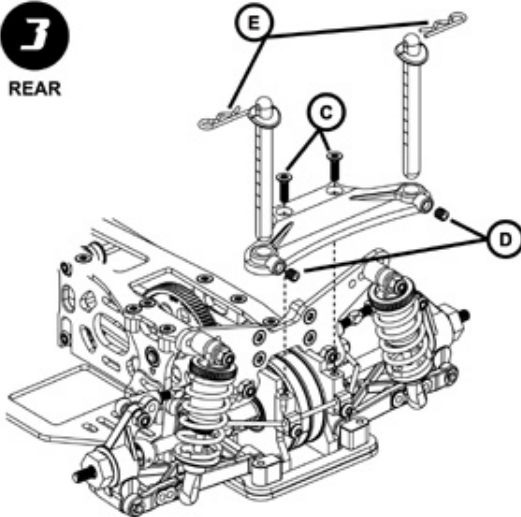

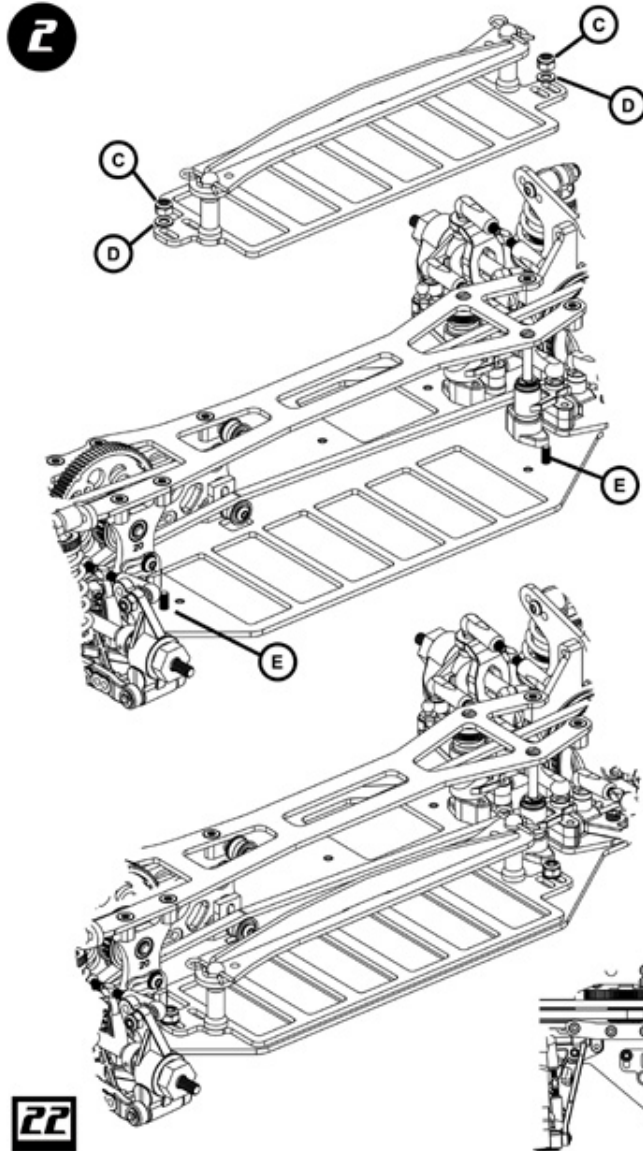
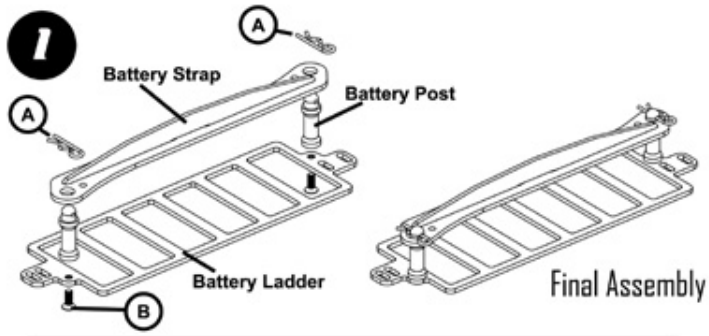





Schumacher

MP2

SADDLE PACK HOLDER ASSEMBLY.

Parts required:

- A**  "R" Clip x 2
- B**  M3 x 10 TORX Csk x 2
- C**  M3 Nyloc Nut x 2
- D**  M3 Steel Washer x 2
- E**  M3 x 8 TORX Csk x 2

TRACK TIP

This setting is "Mid/Outboard" this is a great starting point!



1



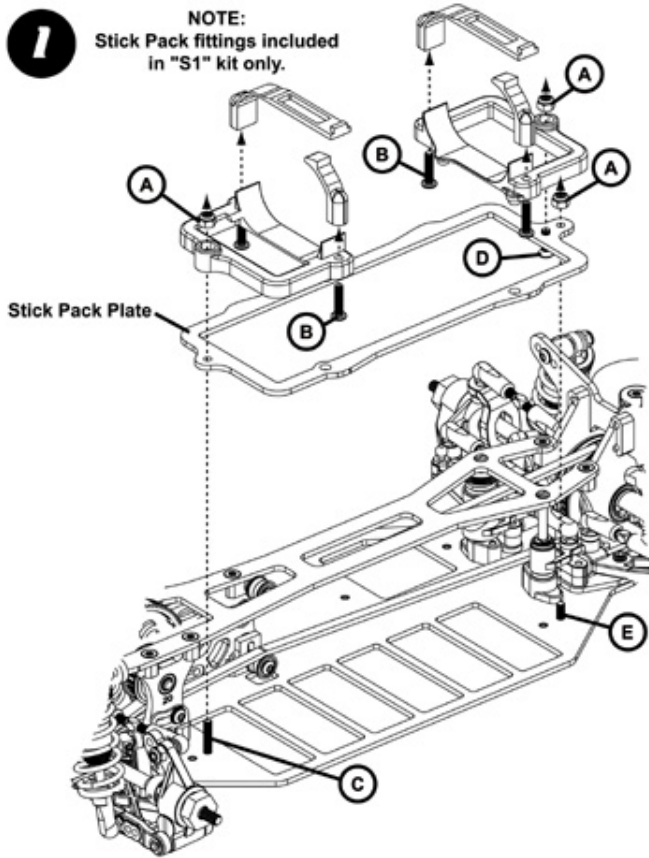

NOTE:
Stick Pack fittings included
in "S1" kit only.



Schumacher

mip

**FITTING A STICK PACK
TYPE BATTERY**

- A**  M3 Nyloc Nut x 3
- B**  M3 x 12 TORX Pan x 4
- C**  M3 x 16 TORX Csk x 1
- D**  M3 x 12 TORX Csk x 1
- E**  M3 x 8 TORX Csk x 1

2

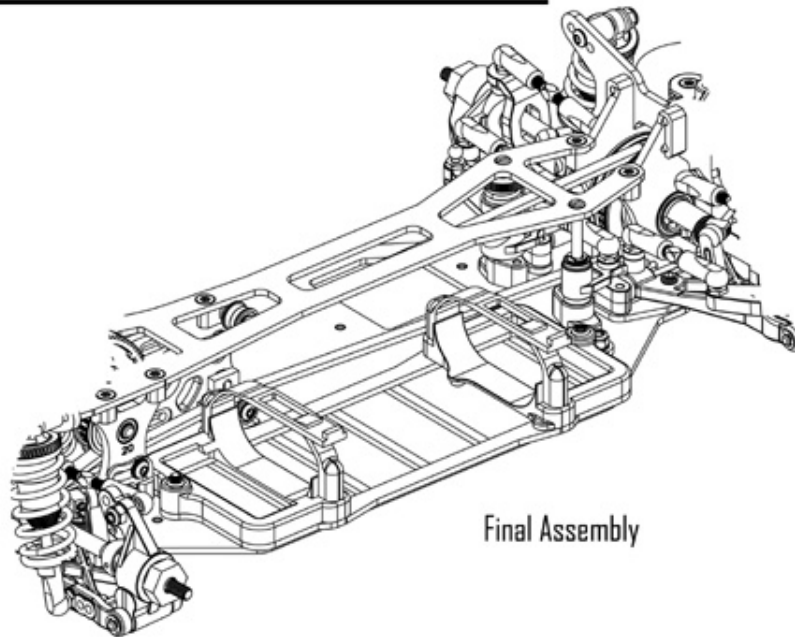

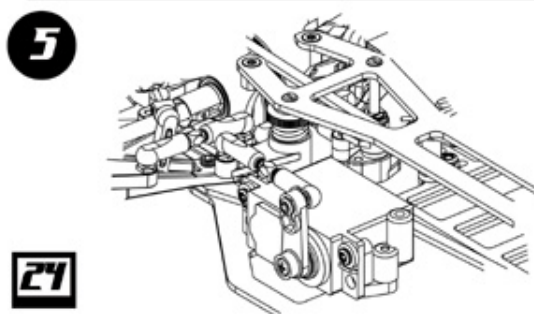
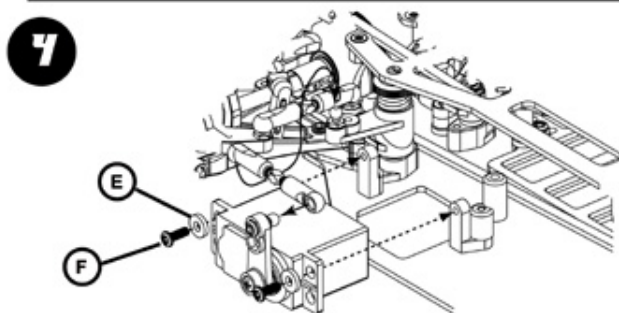
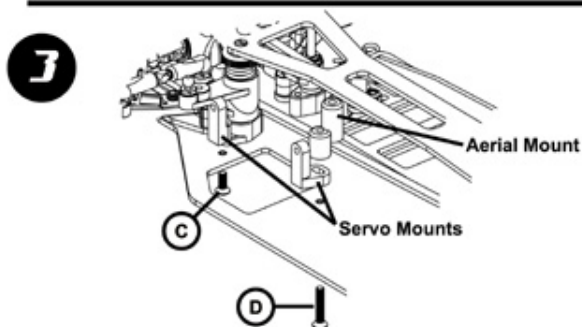
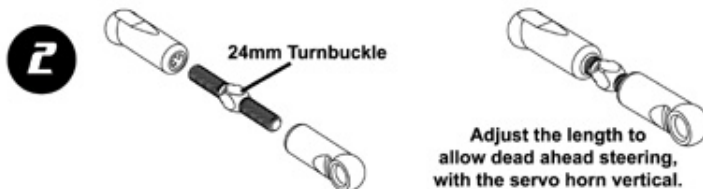
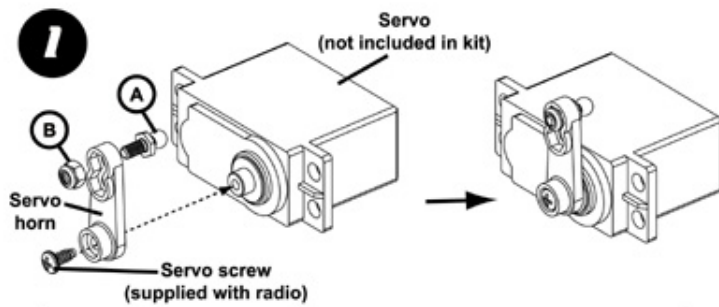







Final Assembly

Schumacher

MP2

RADIO INSTALLATION
Parts required:

- A**  Ball Stud Short M3 x 1
- B**  M3 Nylac Nut x 1
- C**  M3 x 10 Csk TORX x 1
- D**  M3 x 12 Csk TORX x 1
- E**  M3 Steel Washer x 2
- F**  M3 x 8 Pan TORX x 2

TRACK TIP
Make sure your servo is sent to neutral **BEFORE** putting on the servo horn.

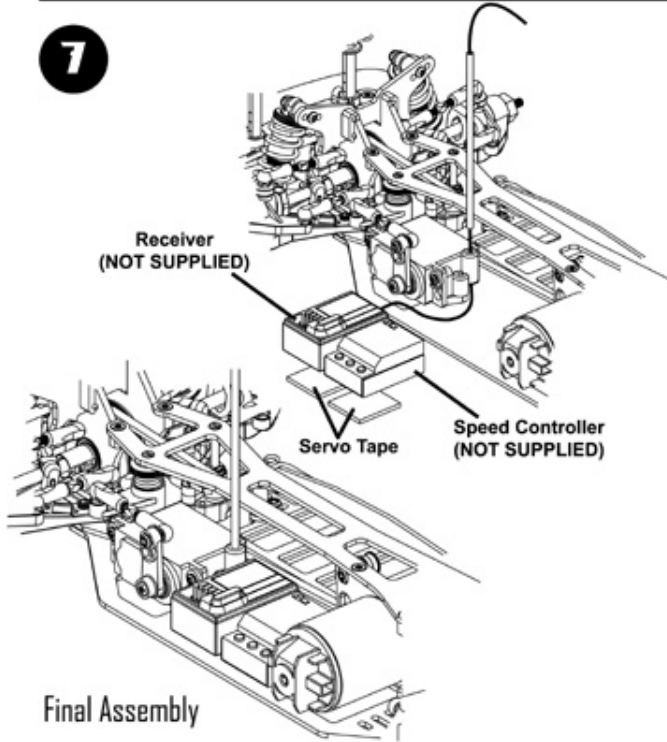
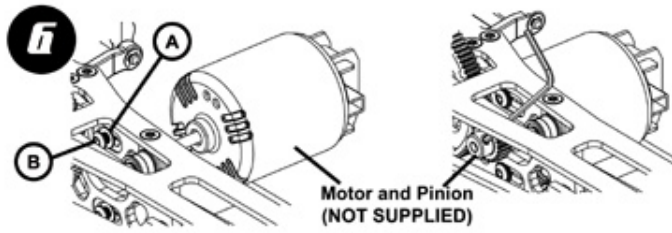

Schumacher

mi2

RADIO INSTALLATION
Cont.

A  M3 Steel Washer x 2

B  M3 x 8 Button Head x 2

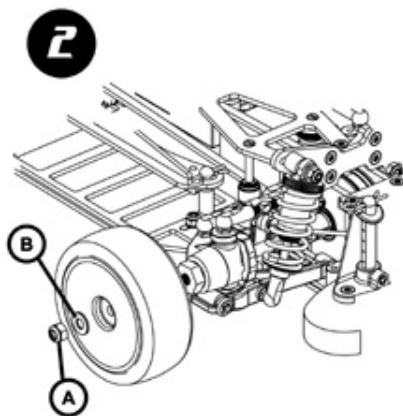
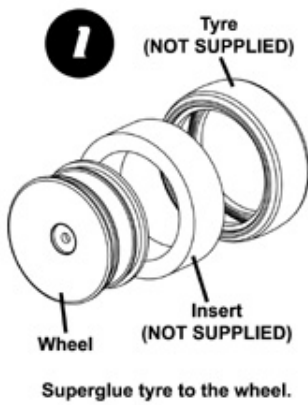

Schumacher

mi2

WHEEL ASSEMBLY

A  M4 Nylac Nut x 4

B  M4 Steel Washer x 4

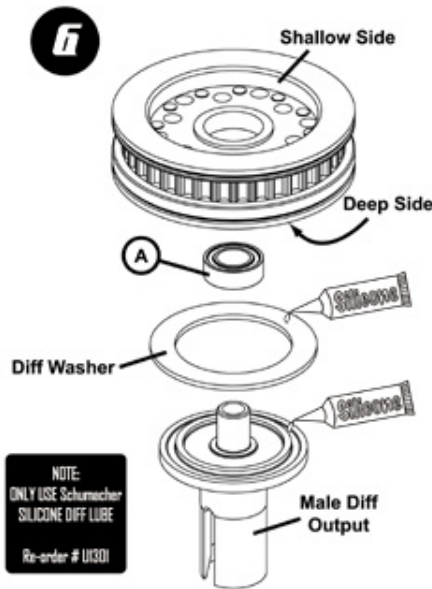
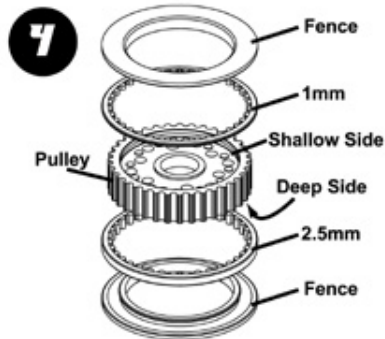
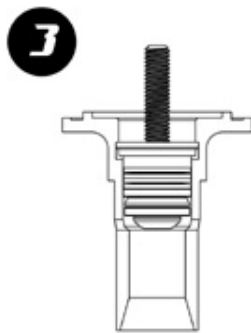
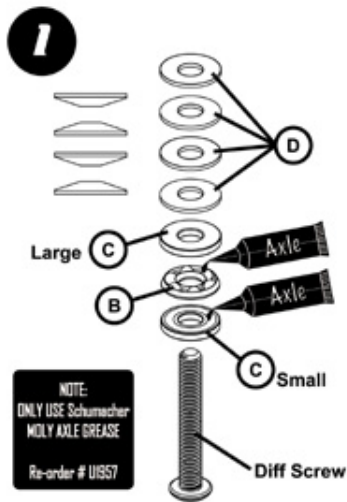

Schumacher

MIR

FRONT DIFFERENTIAL SERVICE

- (A) 5 x 9 x 3 Ball Race x 1
- (B) Thrust Race Cage x 1
- (C) Thrust Washer x 2
(1 x small, 1 x large)
- (D) Diff Disc Spring x 4

TRACK TIP
 Only use
 Schumacher greases
 in your diffs. We
 have done many
 years of testing & we
 know it's the BEST!

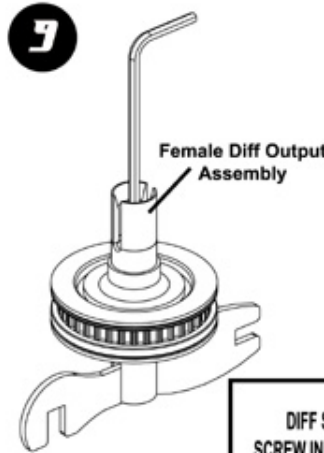
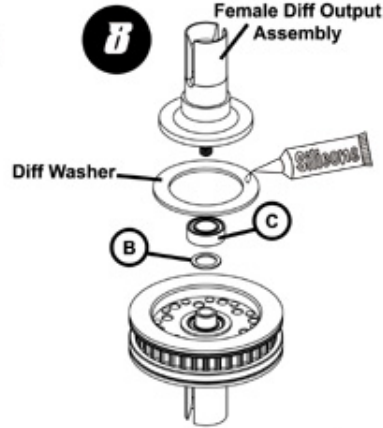

**DIFF SETTING
SCREW IN UNTIL TIGHT
(ALL DISC SPRINGS FLAT)
THEN UNDO 1/4 TURN.

THEN LOCK THE SETTING
WITH THE GRUB SCREW.**

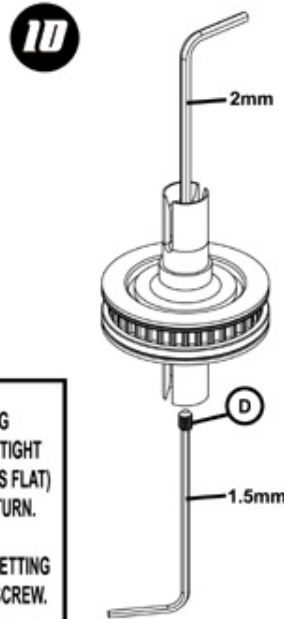

Schumacher

mip

**FRONT DIFFERENTIAL
SERVICE Cont.**

- (A)**  2.5mm Dia Diff Ball x 12
- (B)**  Thin Shim x 1
- (C)**  5 x 9 x 2.5 Open Ball Race x 1
- (D)**  M3 x 4 Grub Screw x 1

TRACK TIP
using the dust cap
will help give the
maximum life to
your diff... USE IT!

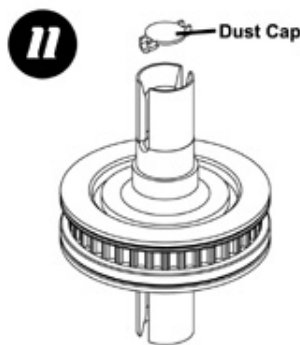

TO LOCK THE FRONT DIFF

It is possible to "lock" the front diff by removing the 2.5mm diff balls and then reassemble as shown above. For information regarding the characteristics of the three types of diff available, see below.

	Differential	Locked	One Way
Off Power Steering	Neutral	Under steer	Oversteer
On Power Steering	Low	High	High
Braking Power	Medium	High	Low
Stability	Neutral	High	Low
Duration / Top Speed	Medium	Low	High



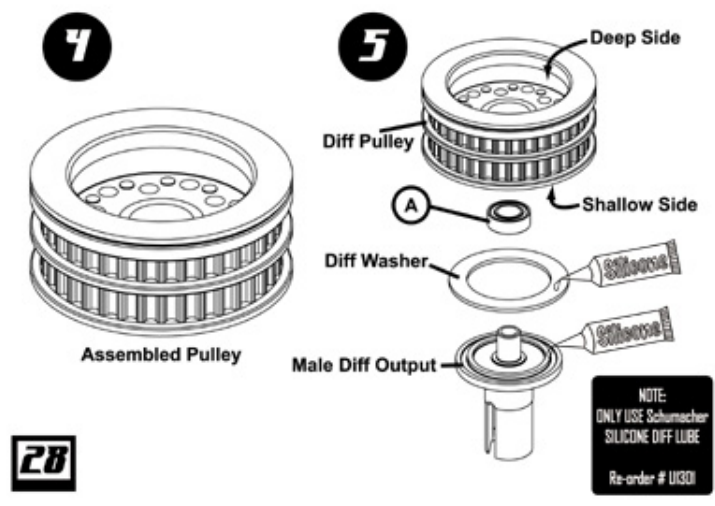
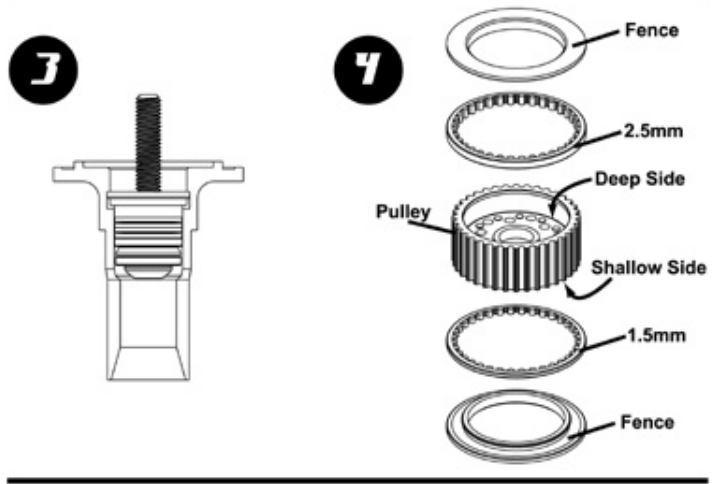
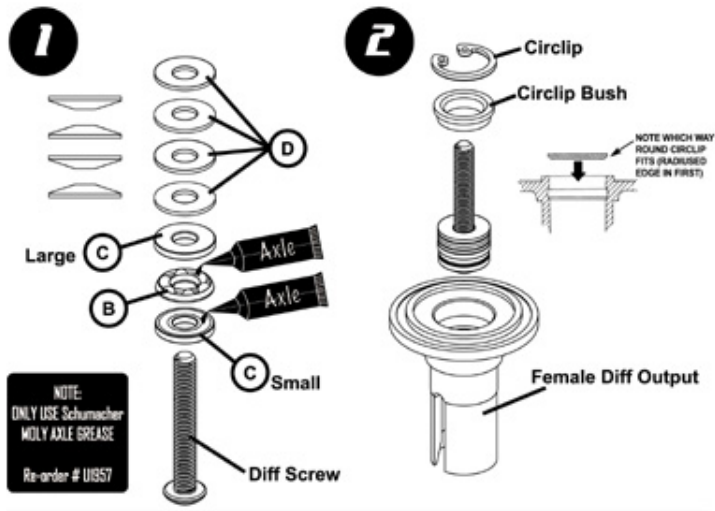

Schumacher

MIR

REAR DIFFERENTIAL SERVICE

A  5 x 9 x 3 Ball Race x 1

B  Thrust Race Cage x 1

C  Thrust Washer x 2
(1 x small, 1 x large)

D  Diff Disc Spring x 4



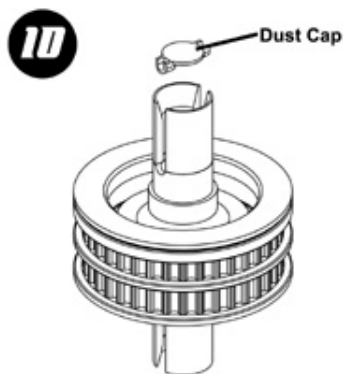
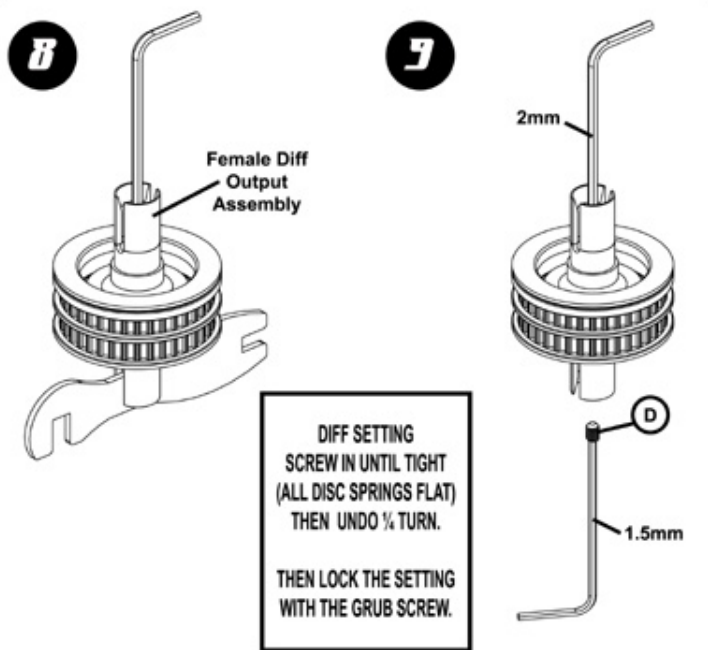
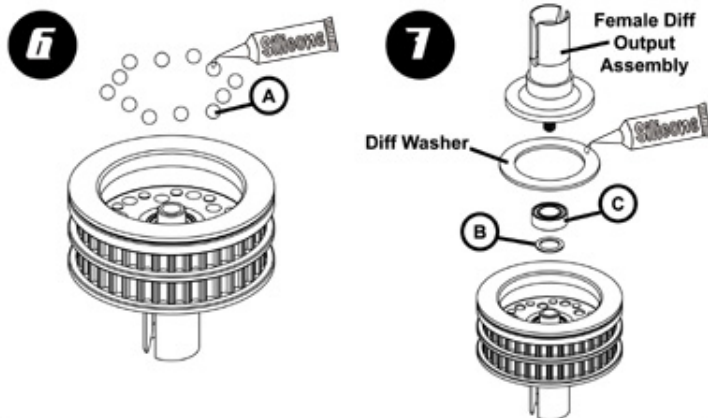

Schumacher

mip

REAR DIFFERENTIAL
SERVICE Cont.

- A**  2.5mm Dia Diff Ball x 12
- B**  Thin Shim x 1
- C**  5 x 9 x 2.5 Open Ball Race x 1
- D**  M3 x 4 Grub Screw x 1

TRACK TIP
Using the Schumacher 'Fibre-Tool' to hold the output doesn't damage the output or your fingers!

REAR TOE-IN (Out-board)

The rear toe-in is set by changing the rear hub carriers.

Toe-In = A less than B

0° toe-in each side is the standard setting. This offers a good level of rear grip.

You can increase the toe-in to 1° or 2° with alloy option parts U2741. Increasing the rear toe-in offers less straight line speed, but increases stability.

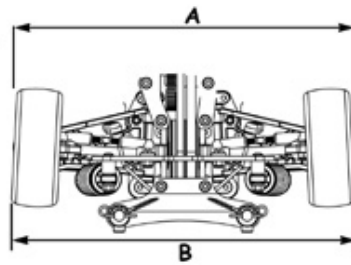

Schumacher

MIA

TRACK SETTINGS
AND
GEAR RATIO CHARTS

REAR TOE-IN (In-board)

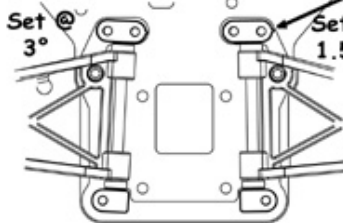

The rear In-Board Toe-In is set by fitting the pivot blocks, with the ridge facing in or out.

Facing in = 3° Toe-In (Standard setting)
Facing out = 1.5° Toe-In

3° Toe-In each side is the standard setting and offers better rear end grip, but less steering response.

1.5° Toe-In each side offers less rear end grip and more steering response.

A 2.5° alloy option is also available. (U2742)

PULLEYS 17/36

Maximum Tooth Sum = 125

Minimum Tooth Sum = 100

2.12 : 1 INTERNAL RATIO

	95	92	89	86	83
15	13.43	13.00	12.57	12.15	
16	12.58	12.19	11.79	11.39	
17	11.84	11.47	11.00	10.72	10.35
18	11.19	10.83	10.48	10.13	9.77
19	10.60	10.26	9.93	9.60	9.26
20	10.07	9.75	9.43	9.12	8.80
21	9.59	9.29	8.98	8.68	8.38
22	9.15	8.87	8.58	8.29	7.99
23	8.76	8.48	8.20	7.93	7.65
24	8.39	8.13	7.86	7.60	7.33
25	8.06	7.80	7.55	7.29	7.04
26	7.75	7.50	7.26	7.01	6.77
27	7.46	7.23	6.99	6.76	6.52
28	7.19	6.97	6.74	6.51	6.29
29	6.95	6.73	6.51	6.29	6.07
30	6.71	6.50	6.29	6.08	5.87
31		6.29	6.09	5.88	5.68
32		6.10	5.90	5.70	5.50

ANTI SQUAT & SUSPENSION DROOP / KICK UP & ANTI-DIVE

The car has 0° anti squat as standard. More anti squat will give more on power traction, however too much will make the car unstable when turning into high speed corners. On slippery tracks add anti squat.

Add Kick Up to make turn in smoother on corner entry and improve the car over bumps.

Anti-Dive increases aggression into the corner.

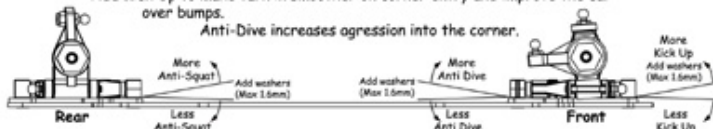

The suspension droop can be adjusted using the grub screw in the lower wishbones. Less front droop improves power on steering. More rear droop increases rear grip, but can make the car unstable under braking.

PULLEYS 20/36

Maximum Tooth Sum = 132

Minimum Tooth Sum = 107

1.8 : 1 INTERNAL RATIO

	95	92	89	86	83
15	11.40	11.04			
16	10.69	10.35			
17	10.06	9.74			
18	9.50	9.20	8.90		
19	9.00	8.72	8.43		
20	8.55	8.28	8.01		
21	8.14	7.89	7.63	7.37	
22	7.77	7.53	7.28	7.04	
23	7.43	7.20	6.97	6.73	
24	7.13	6.90	6.68	6.45	6.22
25	6.84	6.62	6.41	6.19	5.98
26	6.58	6.37	6.16	5.95	5.75
27	6.33	6.13	5.93	5.73	5.53
28	6.11	5.91	5.72	5.53	5.34
29	5.90	5.71	5.52	5.34	5.15
30	5.70	5.52	5.34	5.16	4.98
31	5.52	5.34	5.17	4.99	4.82
32	5.34	5.18	5.01	4.84	4.67

RIDE HEIGHT

In general always run the car as low as possible, without the chassis grounding out, as it rolls into corners.

Run the front 0.5mm to 1.0mm lower than the rear, to give more steering.

A good starting point is 5.5mm at the front and 6.0mm at the rear.

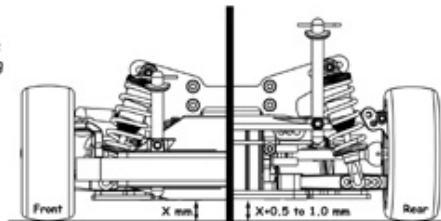

WHEELBASE (set on FRONT & REAR wishbones)

The length of the wheelbase is set by fitting the spacers, in different positions. In front of the wishbone = Long (rear wishbones) Short (front wishbones). Either side of the wishbone = Medium. Behind the wishbone = Short (rear wishbones) Long (front wishbones).

NOTE: The diagrams show the REAR wishbones.

Use spacers to maintain the wheelbase length after adjusting the Castor or Toe-In/Out. In general a longer wheelbase will offer more stability.

Finer adjustment can be gained using the "Kwik Klip" option parts U2251

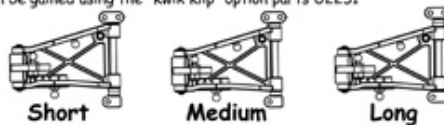

30

FRONT TOE-IN (Out-board)

The front toe-in is set by adjusting the steering trackrod turnbuckles.

Toe-In = A less than B
 Toe-Out = A greater than B

Toe-in will give a more stable car, but will give less sharp turn in. We recommend to start at about 1° each side. Maximum 2° each side.

Toe-out will give the opposite, less stability with sharper turn in to the corners.

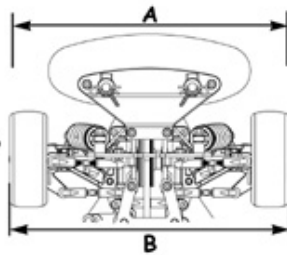

Schumacher



TRACK SETTINGS

LOWER SHOCK POSITION

Standard position is best for most tracks & conditions. The outer position on the rear is good on VERY high grip tracks.

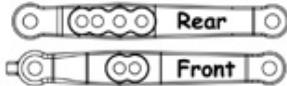

SHOCK BRACKETS (Shock Mounting)

Vertical shock absorbers make the car react sharply to driver inputs.

A laydown shock offers a softer feel to the driver.

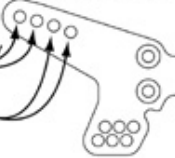

SPRINGS

The spring rate controls the suspension stiffness.

Fit spring spacers only to change the ride height. They DO NOT alter the suspension stiffness. On slippery or bumpy tracks use soft to medium rate springs, on flat or high grip tracks run medium to hard rate springs.



FRONT CASTOR

The front castor can be altered by changing the yoke. The car comes with 4° castor as standard. Less castor will give a quicker steering response, but could lead to power on understeer. More castor will give the opposite, slightly slower turn in, but more power on steering.

2° option -- U2736

6° option -- U2738

4° Purple Alloy -- U2739

NOTE:
 The castor yoke assembly should lean to the rear of the car.

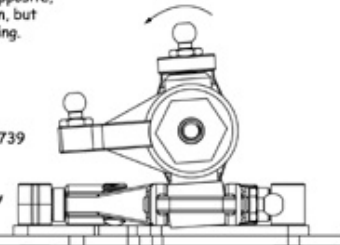

CELL POSITION

The forward cell position gives good steering response on low speed, tight tracks.

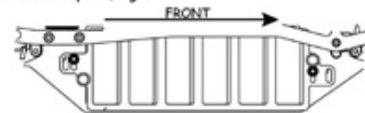

Moving the cells to the rear will give a good balance on high speed, open tracks.

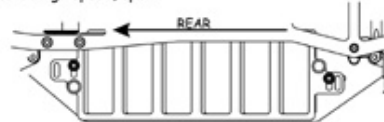

The middle position offers a mix of both!

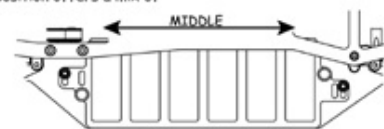

The cell tray has 6mm total movement from the inside to the outside of the car. Use this to help balance the car from left to right.

FRONT & REAR CAMBER

With maximum camber the car will have high levels of grip, but there may be the possibility of sudden breakaway in corners. Reducing the camber gives a more progressive slide, but may give less grip.

SHOCK BRACKETS (Camber Link)

In general the shorter or lower the link, the more grip you get, however the tendency to "break away" is increased.

The longer link offers less grip, but more predictable handling.

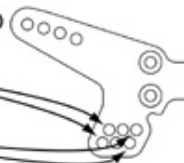













STEERING LEVERS

The three holes on each steering lever allow for changes in both the length and angle of the track rods. These changes will alter the steering response of the car. Generally longer track rods result in less aggressive steering.



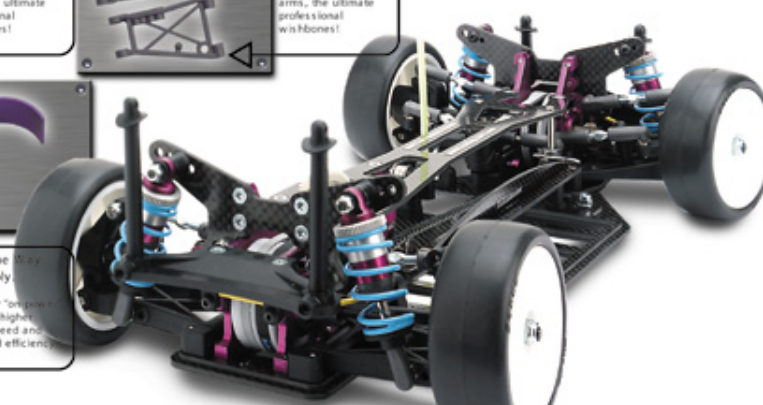

<p>U2744 Purple Alloy Gear Adaptor. CNC machined purple alloy 5 chuk/imb spur gear adaptor.</p> 	<p>U2745 Purple Alloy Shock Seal Housings (pr.). Purple CNC housing. Offers strength and a super smooth operation.</p> 	<p>U2461/04 20t & 31t Alloy Layshaft Pulley. Long lasting, super strong pulley for low maintenance, high performance use.</p> 
<p>U2753 Purple Alloy M4 Nylloc Wheel Nuts. Lightweight flanged purple wheel nuts.</p> 	<p>U2761 Steel CV Drive Shafts. Metal CV shafts that offer strength with style. Complete with Schumachers revolutionary blade system.</p> 	<p>U2401 Purple Alloy Wheel Hex (pr.). Strong, lightweight alloy versions of the standard plastic units found in the kit.</p> 
<p>U2740 Purple Alloy Front Hub Carriers (Pr.). CNC machined alloy. Offers a precise bearing fit and greater strength than the standard unit.</p> 	<p>U2739 Purple Alloy 4" Yokes. CNC machined, to offer more strength and precision.</p> 	<p>U2741 Purple Alloy Rear Hub Carrier. CNC machined purple alloy. Offers great strength and a precise bearing fit.</p> 
<p>U2765 Carbon Fibre Front Wishbones. Lightweight, ultra stiff arms, the ultimate professional wishbones!</p> 	<p>U2766 Carbon Fibre Rear Wishbones. Lightweight, ultra stiff arms, the ultimate professional wishbones!</p> 	
<p>U2724 Purple Alloy SIX fin Motor Heatsink. The best motor heatsink available today! A must for indoor and hot race conditions.</p> 		
<p>U2751 Front One Ray Assembly. For better "on-pipe" steering, higher corner speed and increased efficiency.</p> 