

MISSION

1/10th Scale Professional 4wd Touring Car

Instruction Manual v1.0

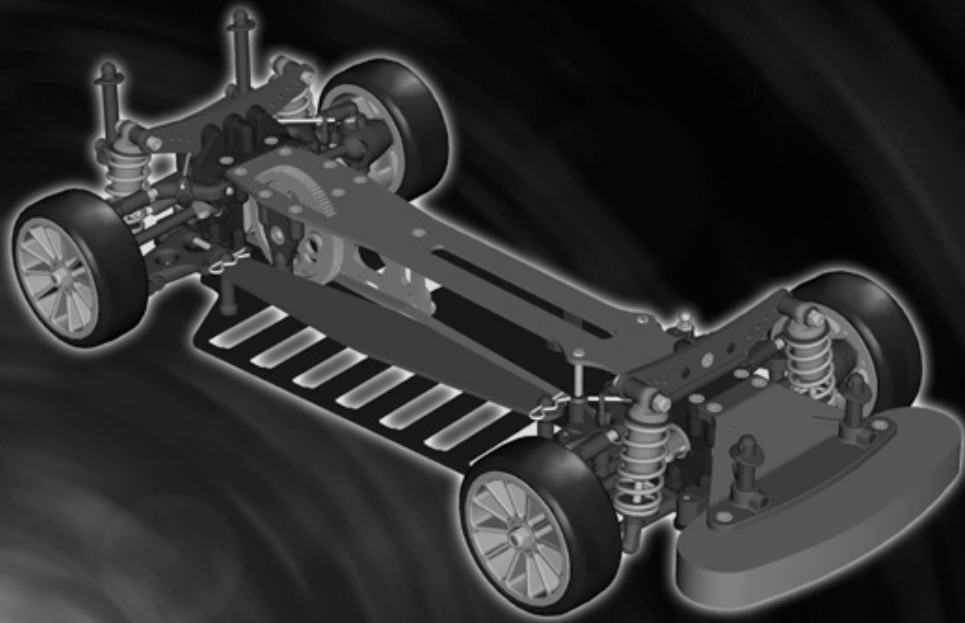

Schumacher Racing
71-73 Tenter Road
Moulton Park
Northampton
NN3 6AX
ENGLAND



www.racing-cars.com







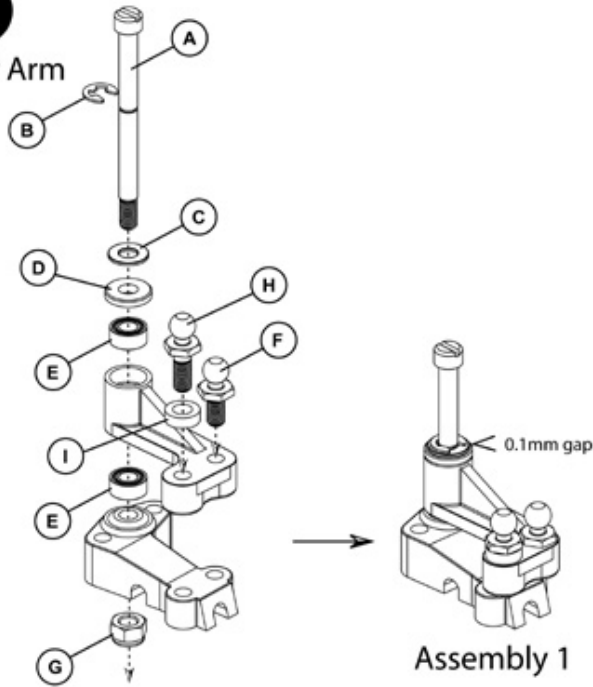

Schumacher USA Inc
6302 Benjamin Road
Suite 404
Tampa
Florida 33634
U.S.A.

S1034

1
Lever Arm



STEERING ASSEMBLY
Parts required:

- A**  Steering Post Long x 2
- B**  "E" Clip x 1
- C**  M3 Steel Washer x 1
- D**  Stepped Washer x 1
- E**  1/8" x 1/4" Ball Race x 4
- F**  Ball Stud Short M3 x 3
- G**  M3 Nyloc Nut x 2
- H**  Ball Stud Long M3 x 2
- I**  2mm Spacer x 2

2
Saver Arm

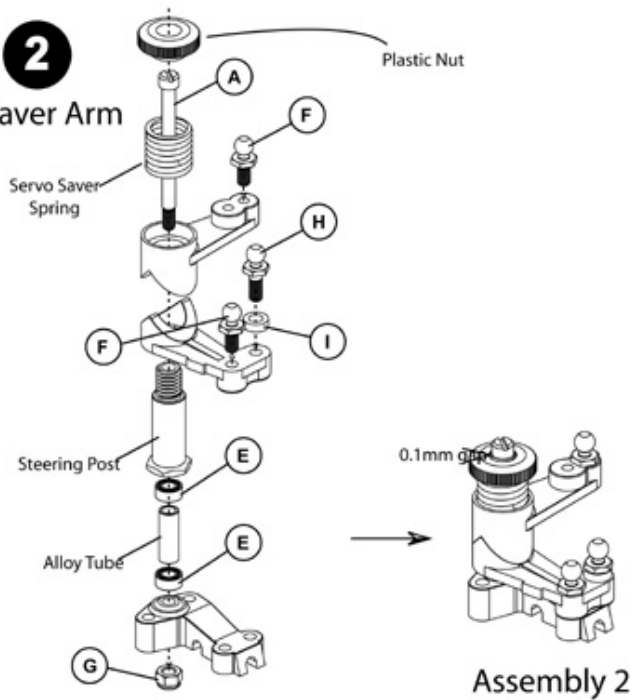

TRACK TIP 01
Ensure that the steering posts are screwed in as vertically as possible (90°).

3

Centre Track Rod

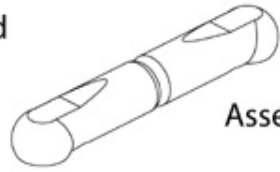

Assembly 3

4

Steering Link
Completion

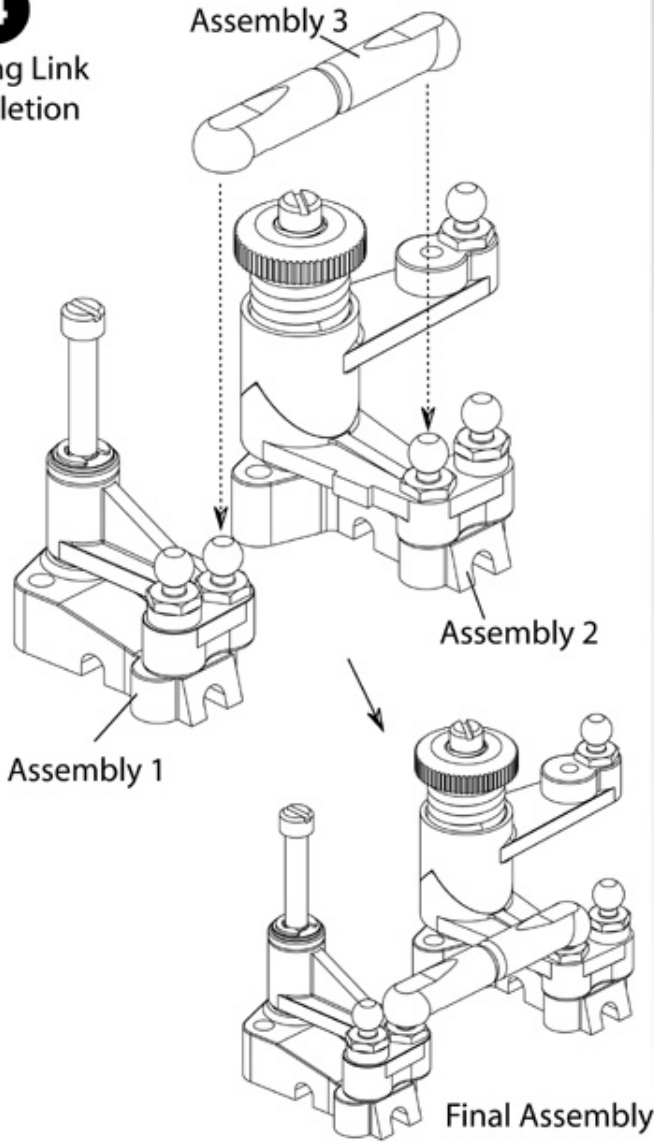

2

Schumacher

MISSION

STEERING ASSEMBLY
Continued

TRACK TIP 02
Always ensure that
the steering arms are
as free as possible,
but with no slop.

1

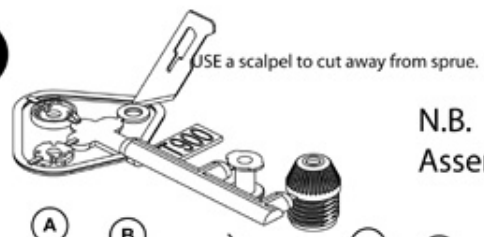

N.B.
Assemble 4 units.



SHOCK ASSEMBLY
Parts required:

- A** Outer Piston x 4
- B** Inner Piston x 4
- C** Spacer x 4
- D** Bobbin x 4
- E** Seal Housing x 4
- F** "E" clip x 8

2

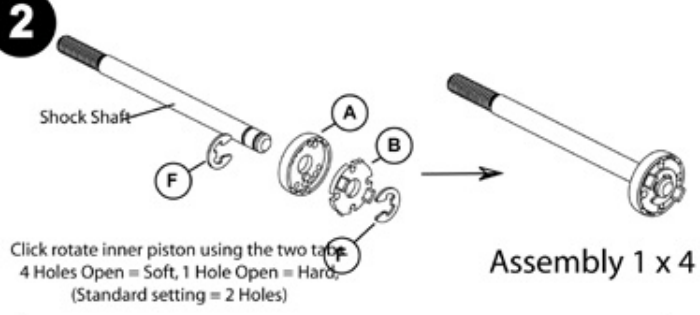

3

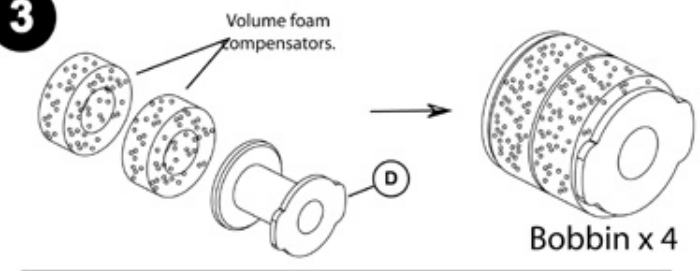

4

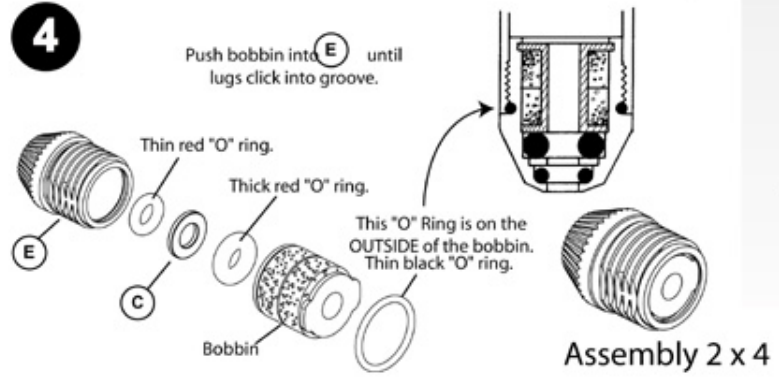

TRACK TIP 03
Soak the volume foam compensators in shock oil before assembly, this will help with air free shocks!

3



SHOCK ASSEMBLY
Parts required:

- A** Ball Socket x 4

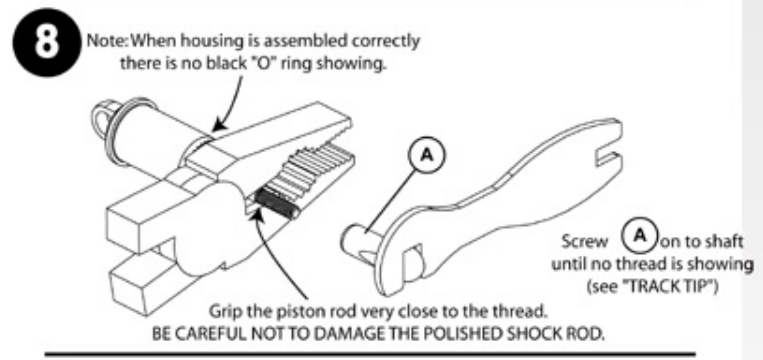
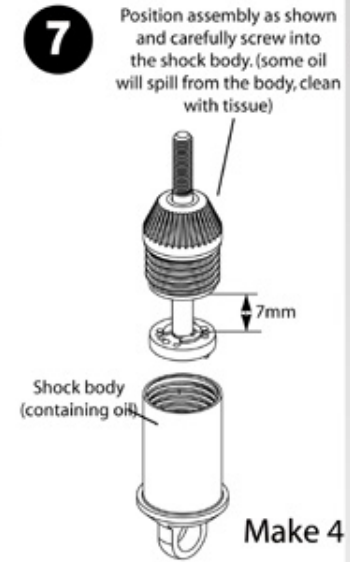
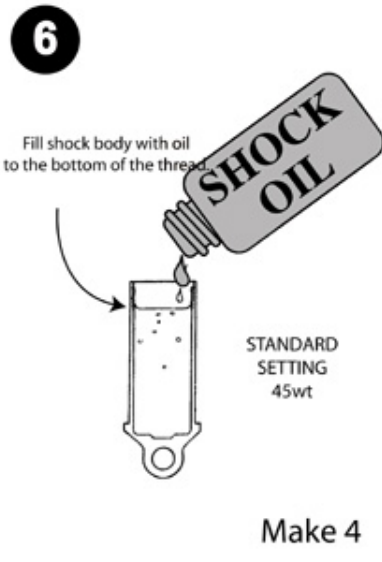

TRACK TIP 04
Ensure the shocks are all the same length!

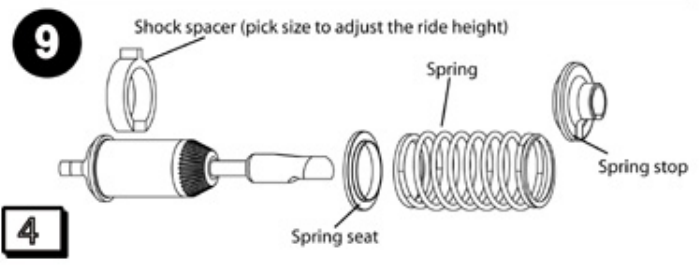

1

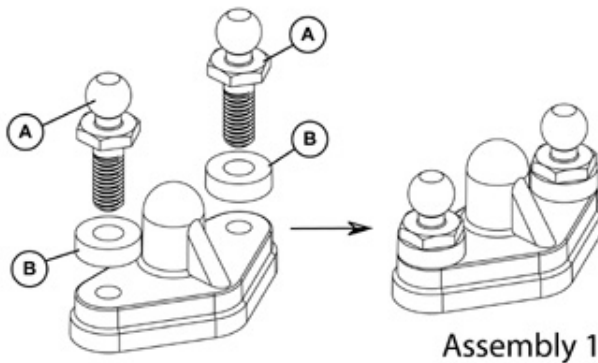

BAG 1 ASSEMBLY
Parts required:

- (A) Ball Stud Long M3 x 2
- (B) 2mm x 3mm Spacer x 2
- (C) No4 1/2" Csk Head x 1
- (D) Allen Ball Stud M3 x 2
- (E) M3 x 6 Grub Screw x 2
- (F) Ball Stud Short M3 x 2
- (G) 2mm x 1/8" spacer x 4
- (H) No4 3/8 Csk Head x 6

2

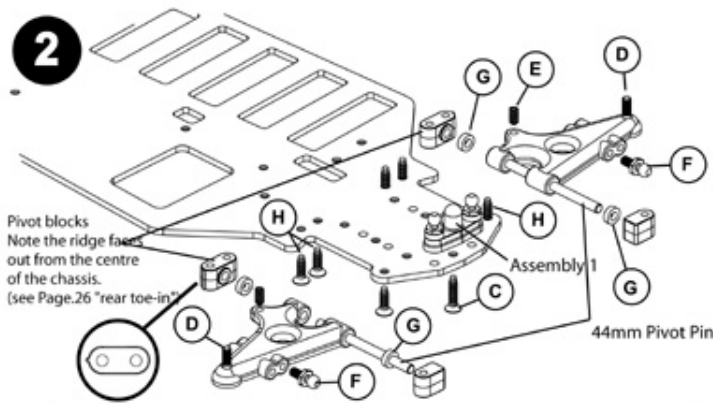

3

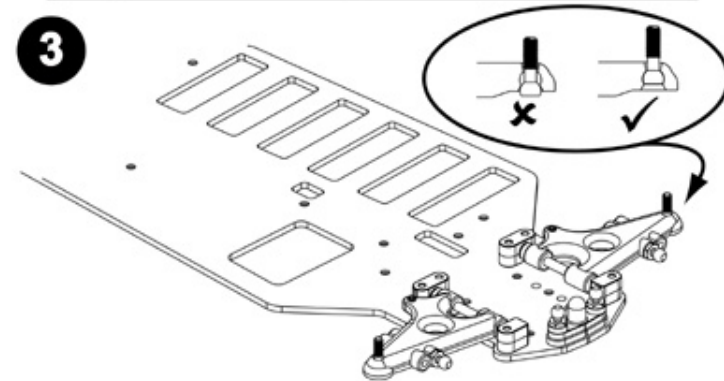

TRACK TIP 05
Adjust the grub screws so that the wishbones are flush with the bottom of the chassis.

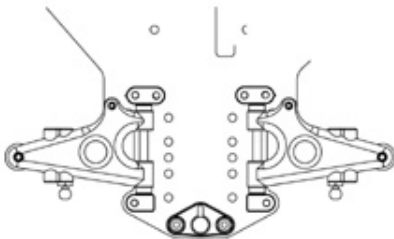

Final Assembly

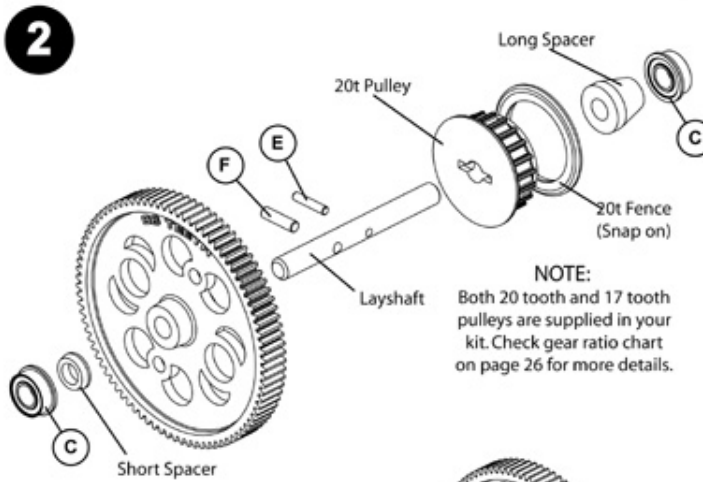
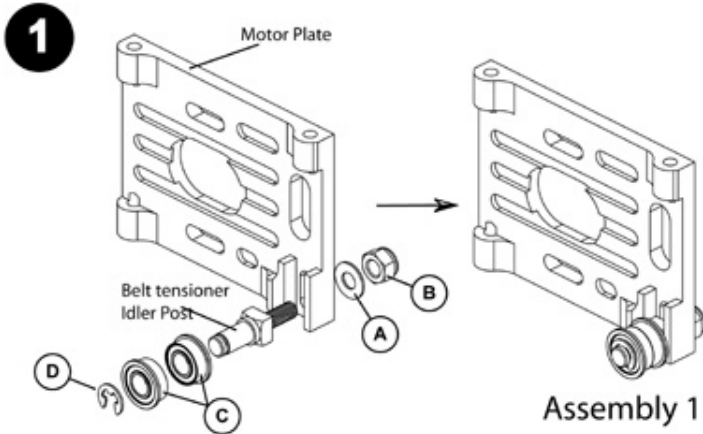

NOTE:
Both 20 tooth and 17 tooth pulleys are supplied in your kit. Check gear ratio chart on page 26 for more details.

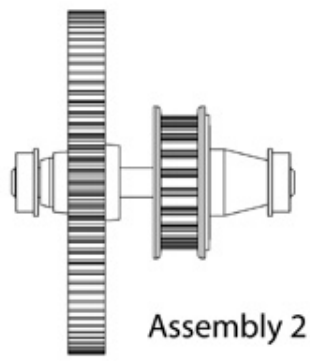

6



BAG 2 ASSEMBLY
Parts required:

- A** M3 Steel Washer x 1
- B** M3 Nyloc Nut x 1
- C** 4 x 8 x 3 Flanged Ball Race x 4
- D** "E" Clip x 1
- E** 1.5mm x 7.8mm Needle Roller x 1
- F** 2mm x 7.8mm Needle Roller x 1

TRACK TIP 06
Temporarily set belt tensioner at it's lowest possible setting.

3

NOTE:

The position of the layshaft mount.

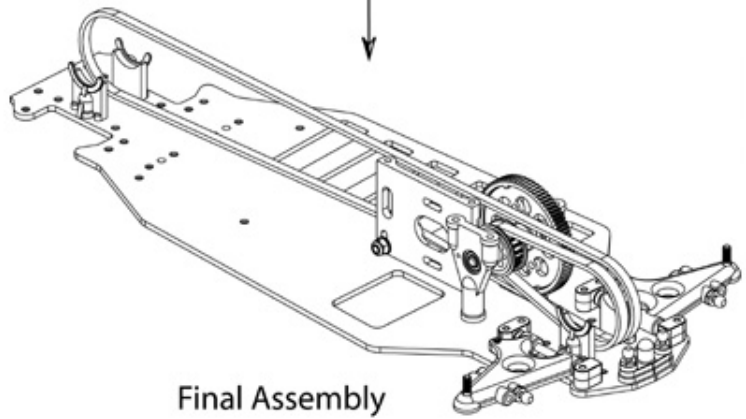
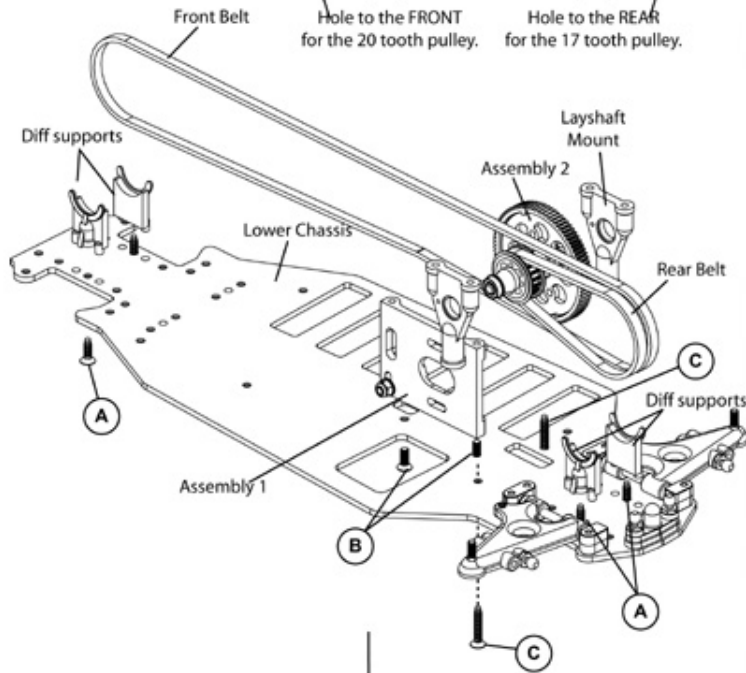
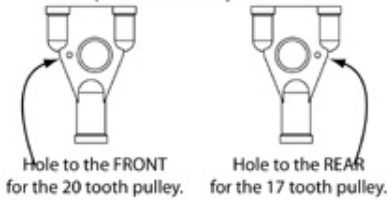

Final Assembly

Schumacher

MISSION

BAG 2 ASSEMBLY Parts required:

- A**  No4 3/8 Csk Head x 4
- B**  M3 x 8 Csk Head x 2
- C**  No4 5/8 Csk Head x 2

TRACK TIP 07
DO NOT "crimp" the belts during assembly.

7

1

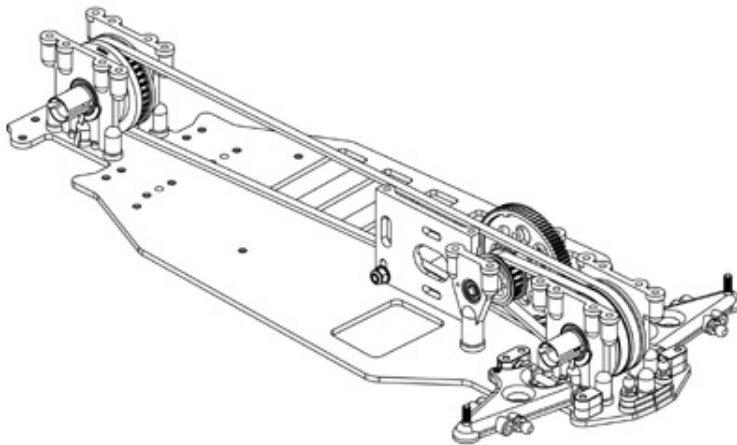
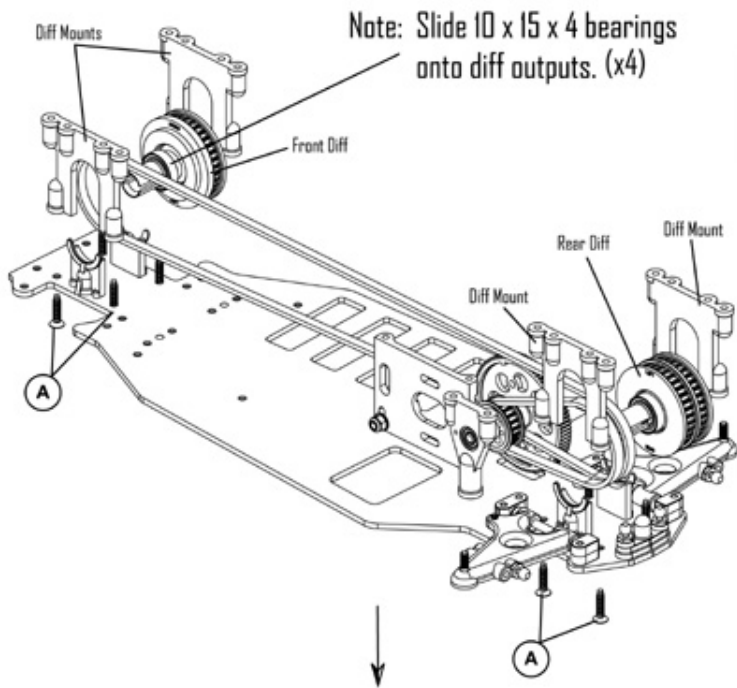

Final Assembly

Schumacher

MISSION

BAG 3 ASSEMBLY
Parts required:

- A  No4 1/2 Csk Head x 8

TRACK TIP 08
 Make sure that both diffs are fitted the correct way round.

8

1

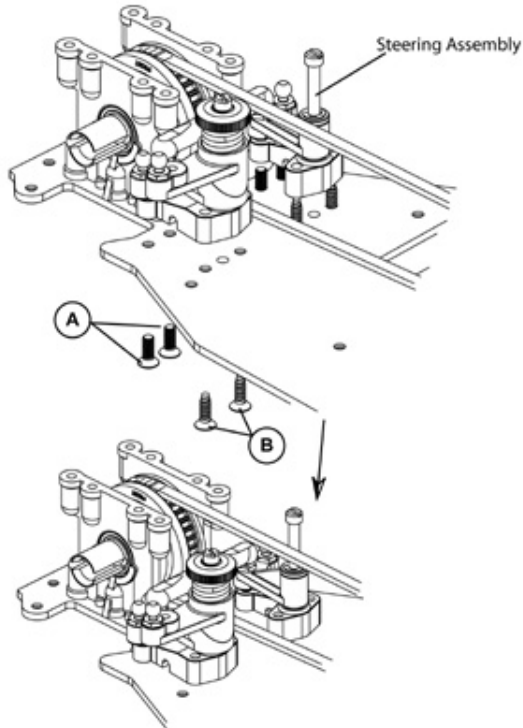

BAG 4 ASSEMBLY
Parts required:

- A** M3 x 8 Csk Head x 4
- B** No4 3/8 Csk Head x 4
- C** Red "O" ring x 2
- D** M3 x 6 Grub Screw x 2
- E** Allen Ball Stud M3 x 2
- F** Ball Stud Short M3 x 2
- G** 2mm x 1/8" spacer x 2
- H** No4 1/2 Csk Head x 2

2

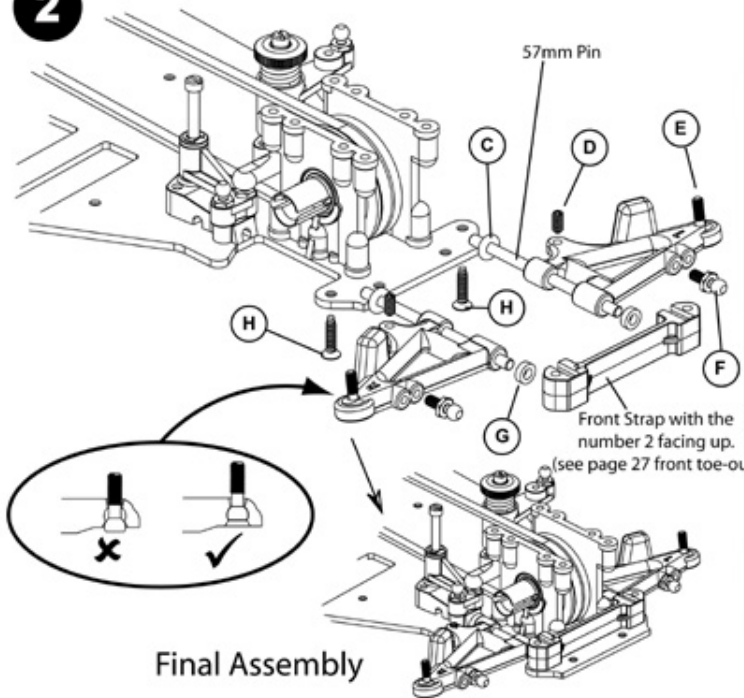

TRACK TIP 09
Adjust the grub screws so that the wishbones are flush with the bottom of the chassis.

9

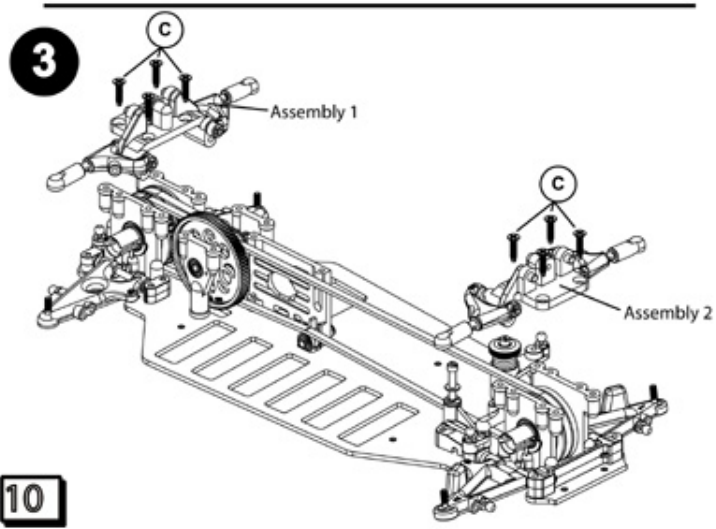
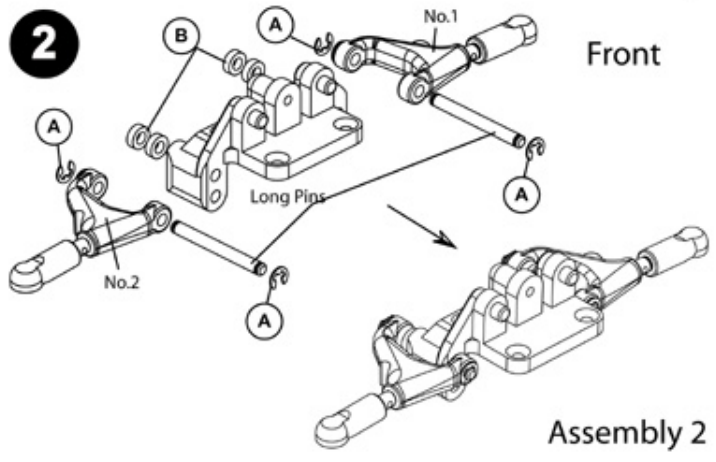
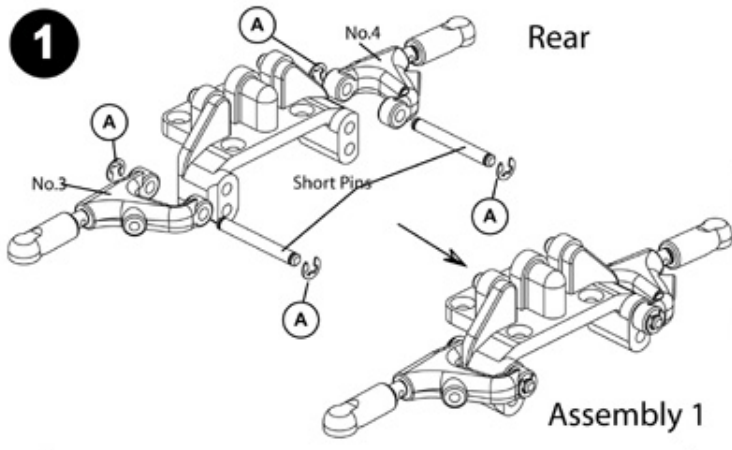

BAG 5 ASSEMBLY
Parts required:

- A** "E" Clip x 8
- B** 2mm x 1/8" spacer x 4
- C** No4 1/2 Csk Head x 8



TRACK TIP 10
Adjust the upper wishbone turnbuckle, using the "fibre-tool" and a 1.5mm allen key. This "un-sticks" the plastic from the thread. This makes future adjustment easier when your MISSION is fully assembled!

4

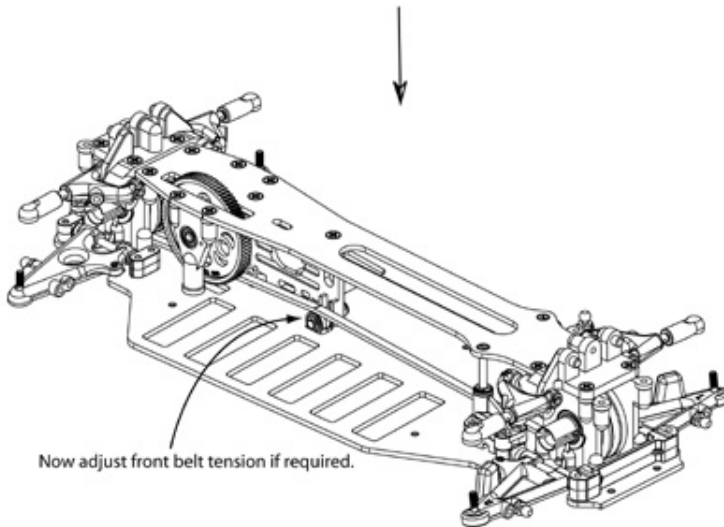
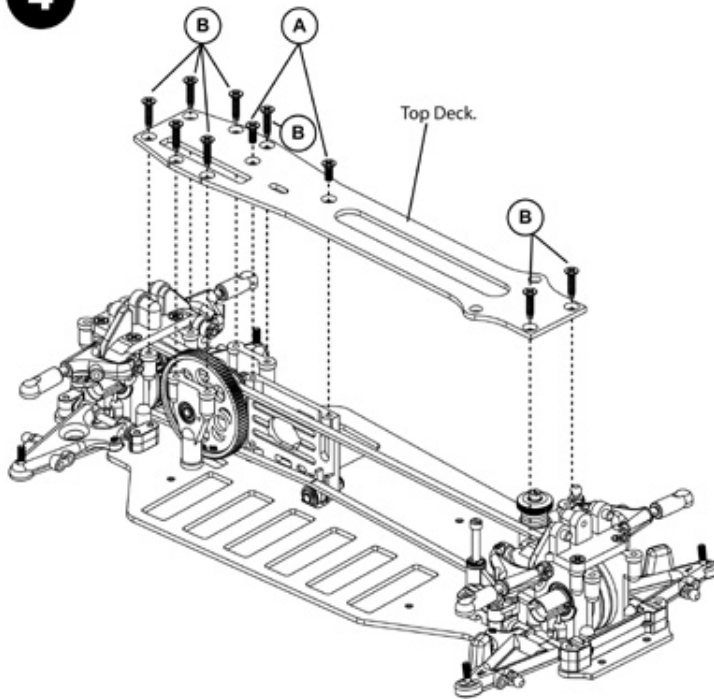

Final Assembly

Schumacher

MISSION

BAG 5 ASSEMBLY
Parts required:

- A**  M3 x 8 Csk Head x 2
- B**  No4 1/2 Csk Head x 8

TRACK TIP 11
The belt should be adjusted to give minimum tension, with no belt jump.

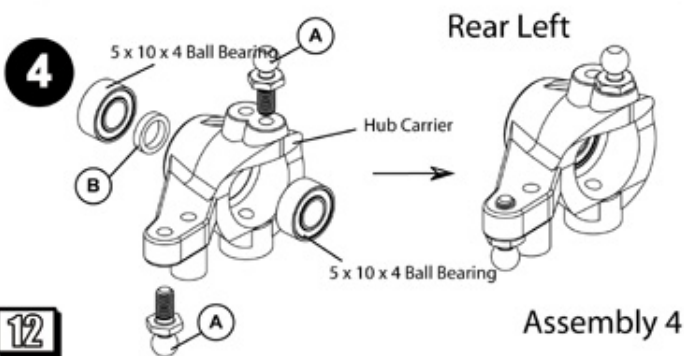
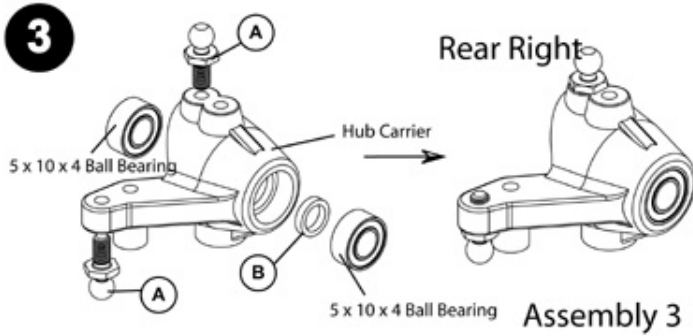
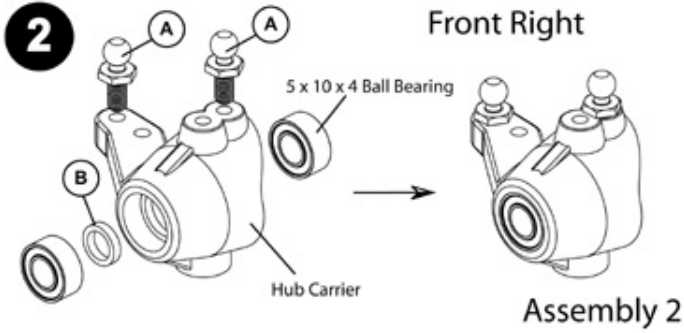
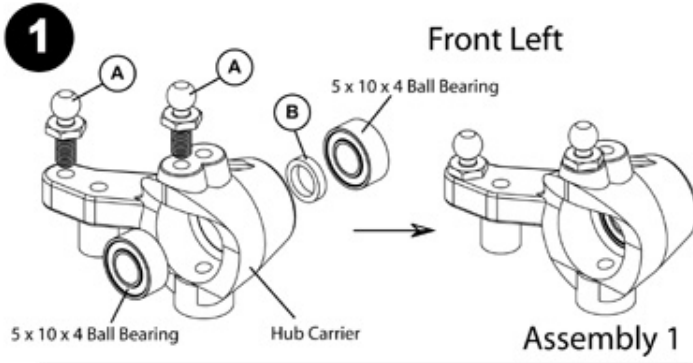

12

Schumacher

MISSION

BAG 6 ASSEMBLY
Parts required:

A  Ball Stud Short M3 x 8

B  Thick wheel shim x 4

TRACK TIP 12
Ensure all the ball studs are fully screwed in.

5

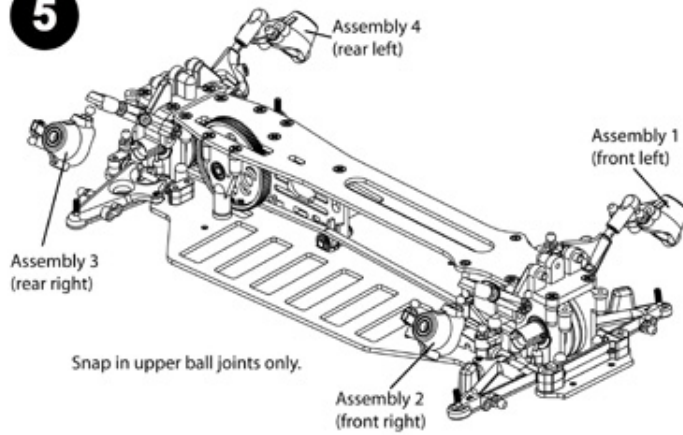

Schumacher

MISSION

BAG 6 ASSEMBLY

6

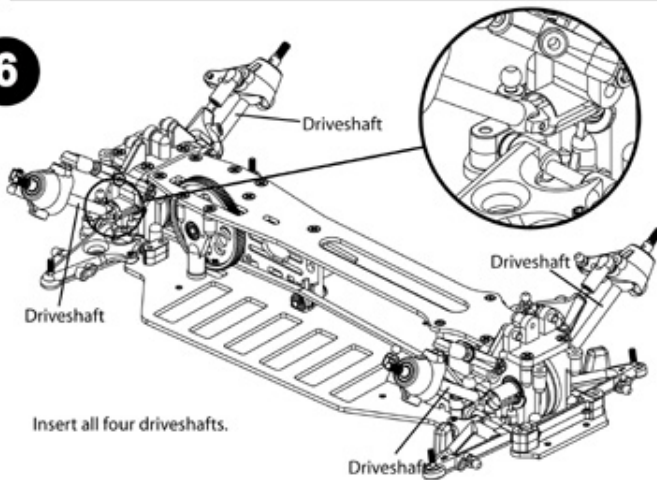

7

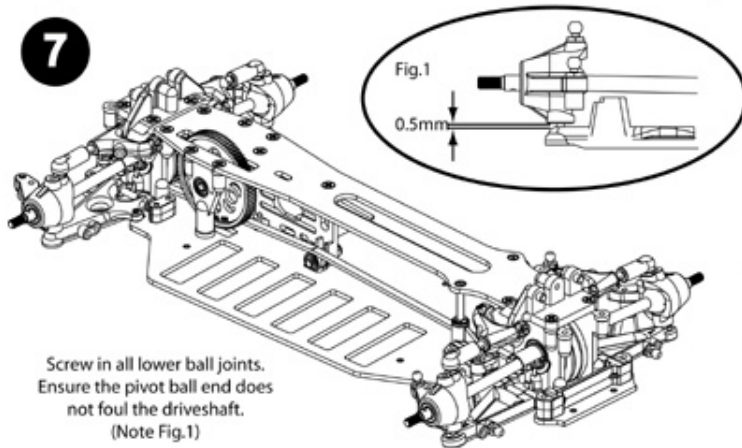

TRACK TIP 13
Place driveshaft blades into the outputs before screwing in lower ball joints.

8

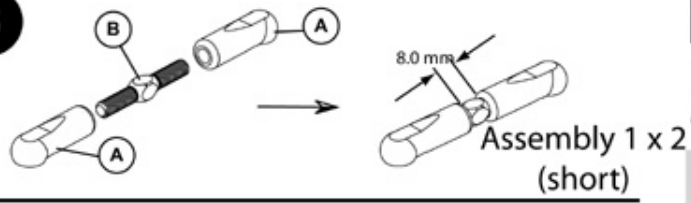

9

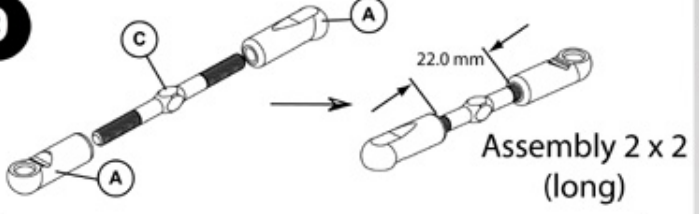

10

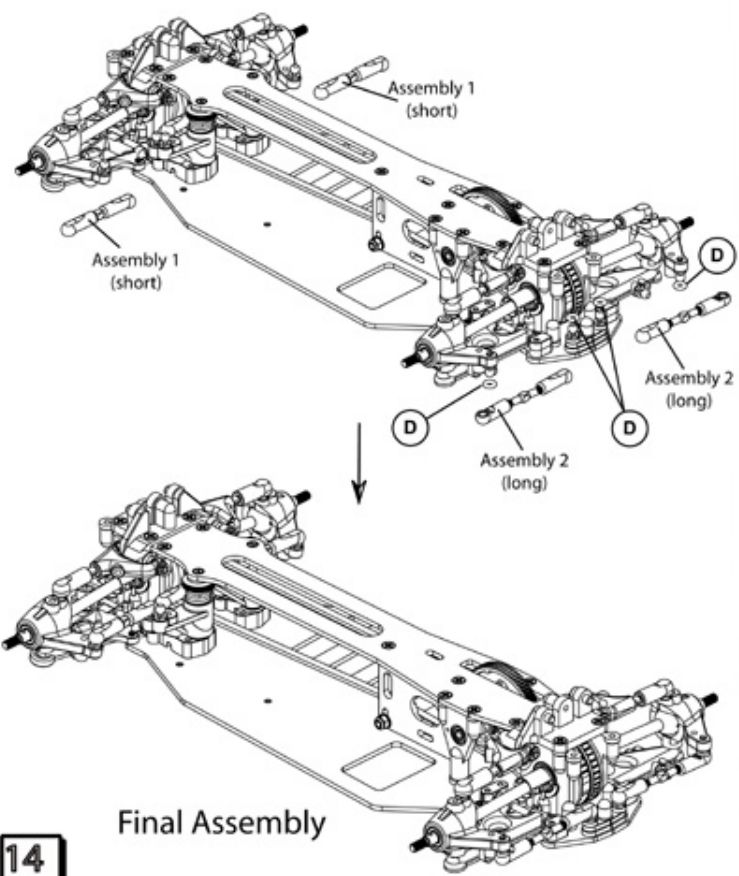

14



BAG 6 ASSEMBLY
Parts required:

- (A) Ball Socket x 8
- (B) 24mm Turnbuckle x 2
- (C) 39mm Turnbuckle x 2
- (D) Small Red "O" Ring x 4

TRACK TIP 14
Make the final toe-in settings after the wheels are fitted.

1

Front

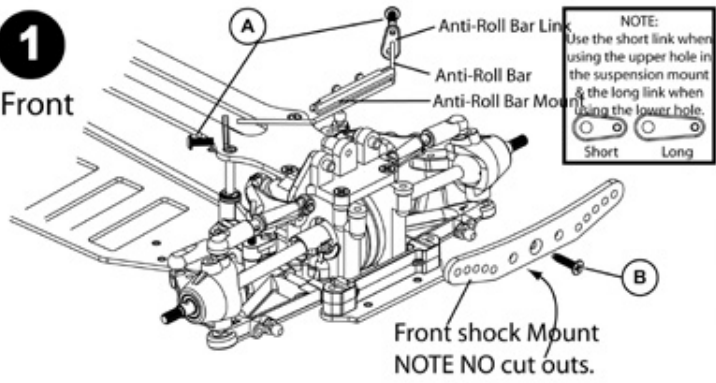

2

Connect to ball stud

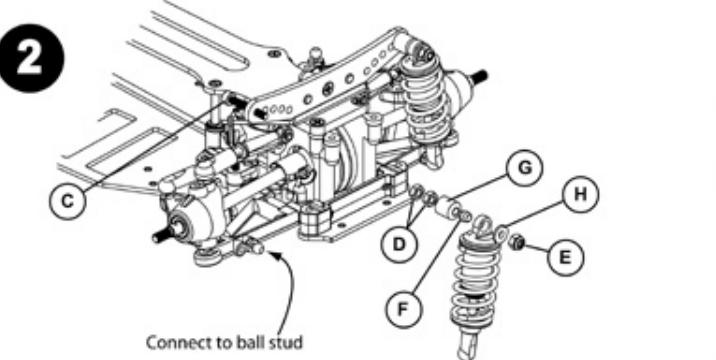

3

Rear

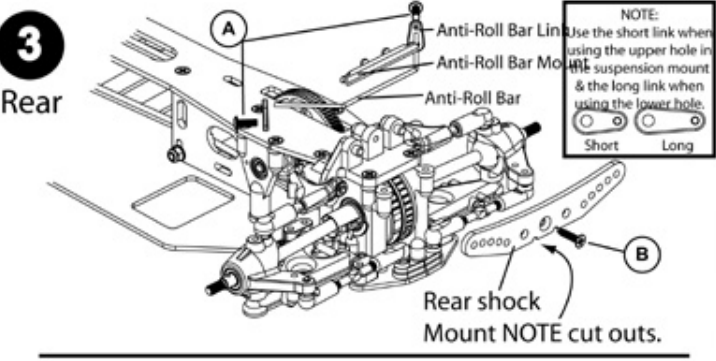

4

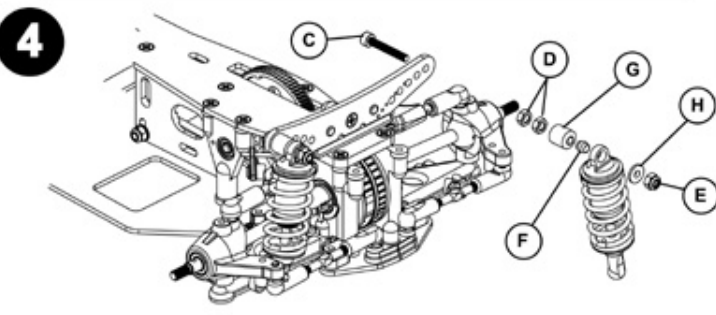

BAG 7 ASSEMBLY
Parts required:

- A** M3 x 8 Button Head x 4
- B** No4 1/2 Csk Head x 2
- C** M3 x 20 Cap Head x 4
- D** M3 Nut x 8
- E** M3 Nyloc Nut x 4
- F** Shock Mount Bush x 4
- G** Shock Mount Collar x 4
- H** Shock Mount Washer x 4

TRACK TIP 15
Don't over tighten the shock fixings **E** or the anti-roll bar screws **A**. They must be allowed to pivot freely as the suspension moves.

NOTE:
Front & Rear mounts are different.

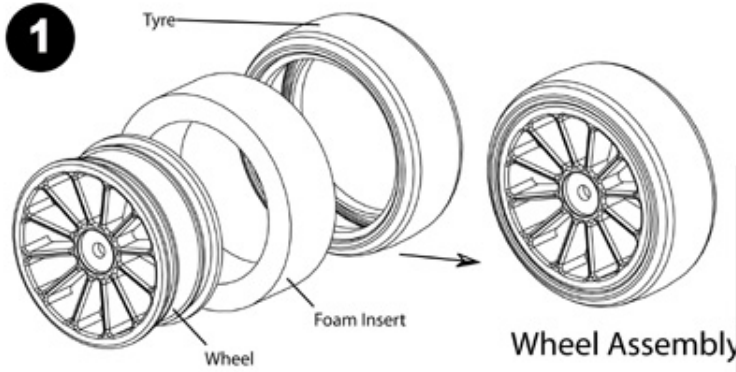

Schumacher
MISSION

BAG 8 ASSEMBLY
Parts required:

- A**  1.5mm x 11.8mm Needle Roller x 4
- B**  Thin Wheel Shim x 4
- C**  Pin Drive Disc Spring x 4
- D**  M4 Steel Washer x 4
- E**  M4 Nyloc Nut x 4
- F**  Pin Drive Hex x 4

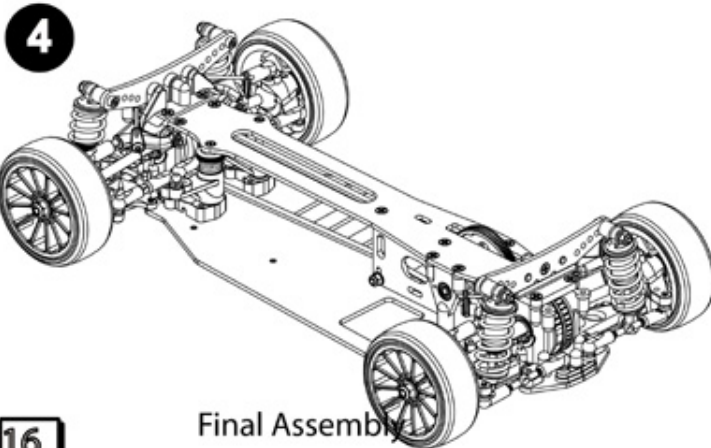
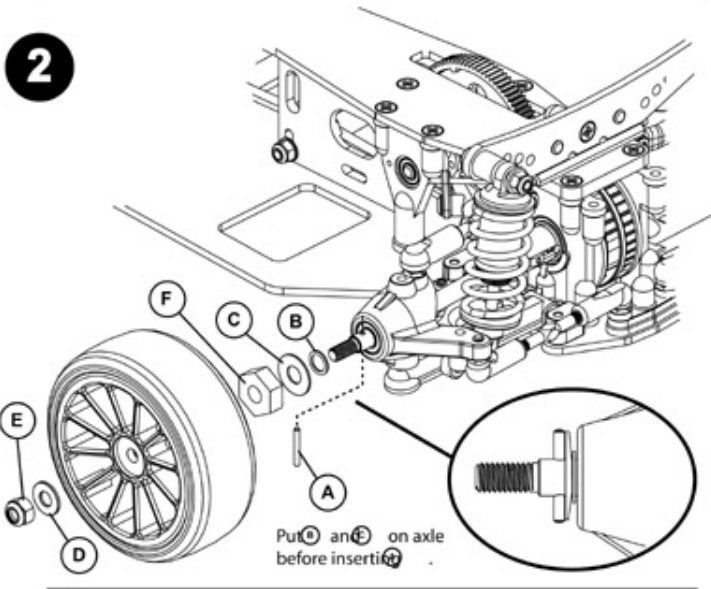

16

Final Assembly

TRACK TIP 16
Take time to seat the foam insert correctly into the tyre before fitting to the wheel. Then carefully stick with superglue.

1
REAR

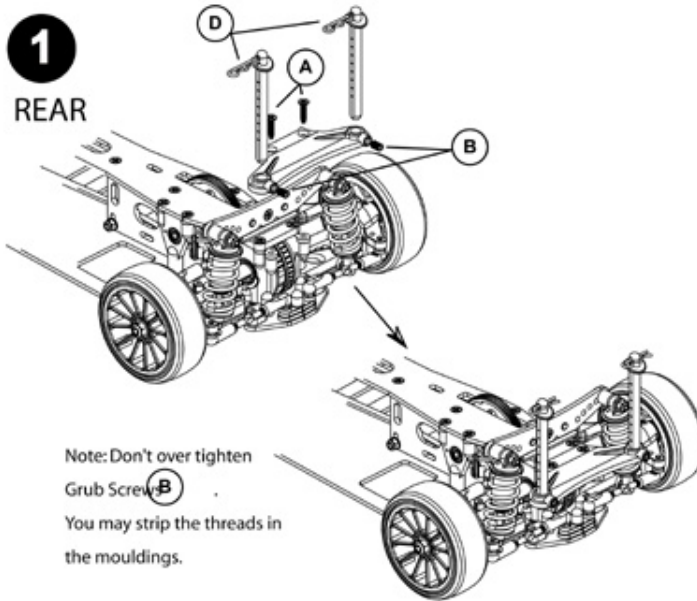

Note: Don't over tighten
Grub Screw **B**.
You may strip the threads in
the mouldings.

**BODY MOUNTS
AND BUMPER**

- A**  No. 4 1/2 Csk Head x 6
- B**  M4 x 6 Grub Screw x 4
- C**  No. 4 5/8 Csk Head x 2
- D**  "R" Clip x 4

2
FRONT

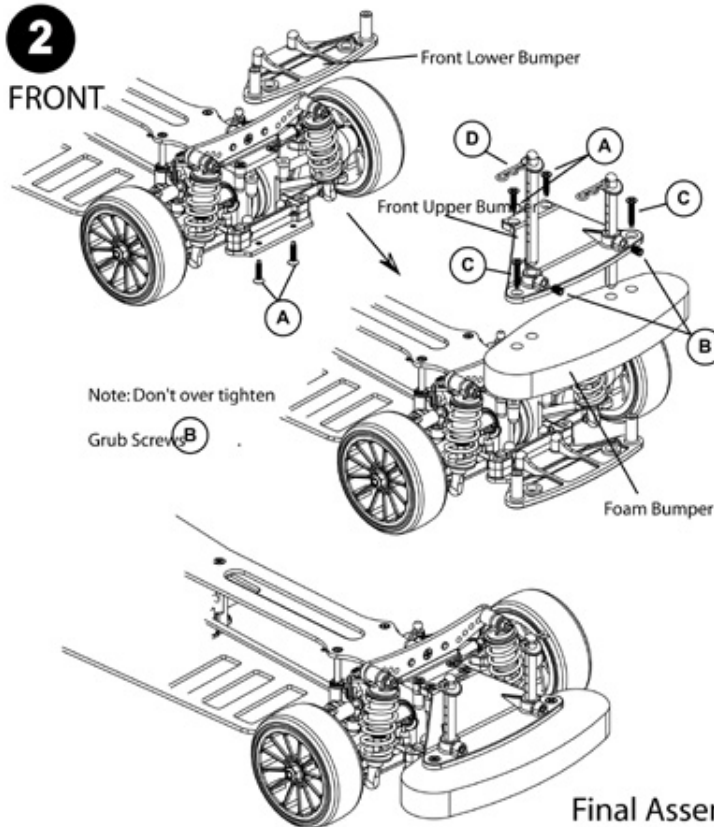

Note: Don't over tighten
Grub Screw **B**.

TRACK TIP 17
Cut the body mounts
after you have
decided on your
bodyshell. It is easier
to drill & mount your
bodyshell before
you paint it.

Final Assembly

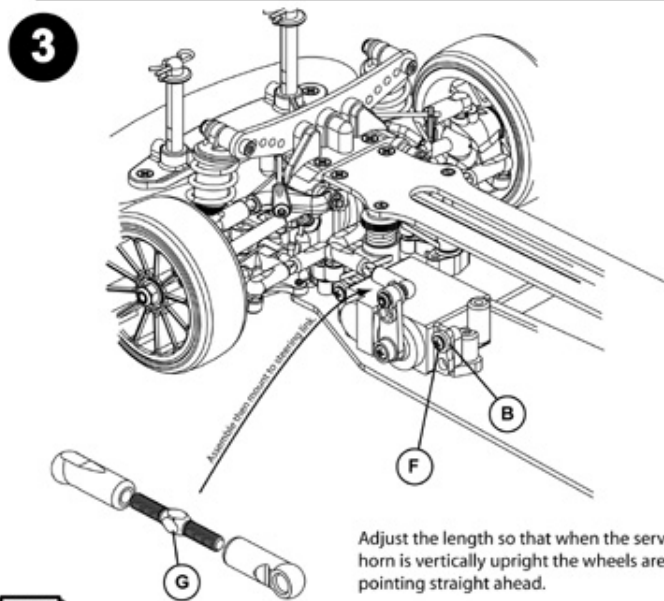
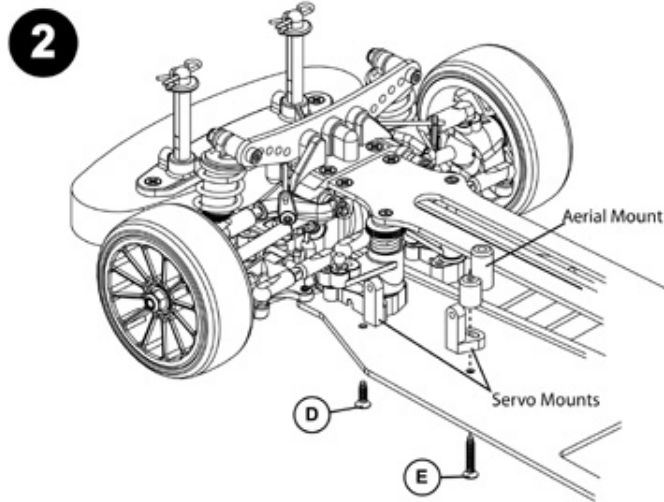
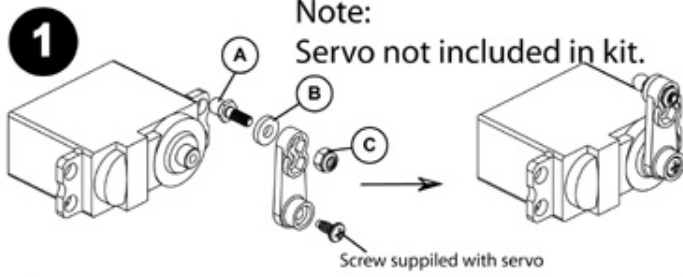







18

Schumacher

MISSION

SERVO ASSEMBLY
Parts required:

- A**  Ball Stud Long M3 x 1
- B**  1.6mm Nylon Washer x 3
- C**  M3 Nyloc Nut x 1
- D**  No4 3/8 Csk Head x 1
- E**  No4 5/8 Csk Head x 1
- F**  No4 3/8 Pan Head x 2
- G**  24mm Turnbuckle x 1

TRACK TIP 18
Make sure the servo is at neutral before installing the horn.

4

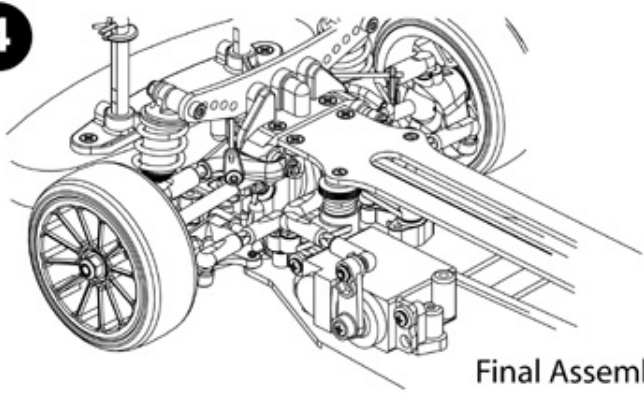

Final Assembly

Schumacher

MISSION

MOTOR & PINION
Parts required:

- A**  M3 Steel Washer x 2
- B**  M3 x 8 Button Head x 2

1

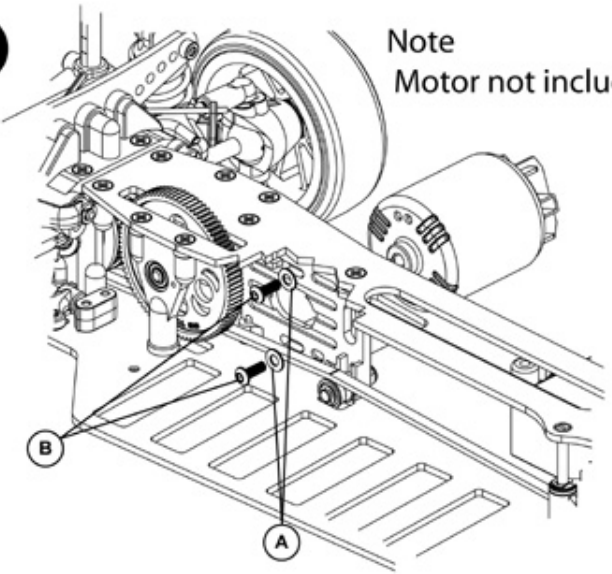

Note
Motor not included

2

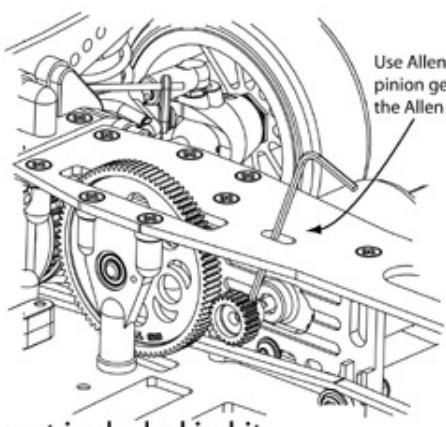

Use Allen Key provided to t
pinion gear to motor then l
the Allen Key!

Note:
Pinion not included in kit.

TRACK TIP 19
Rotate the spur gear
and check the gear
mesh at 3 or 4
different positions,
to make sure there
are no high spots
or excessive play.

SADDLE PACK BATTERY MOUNTING

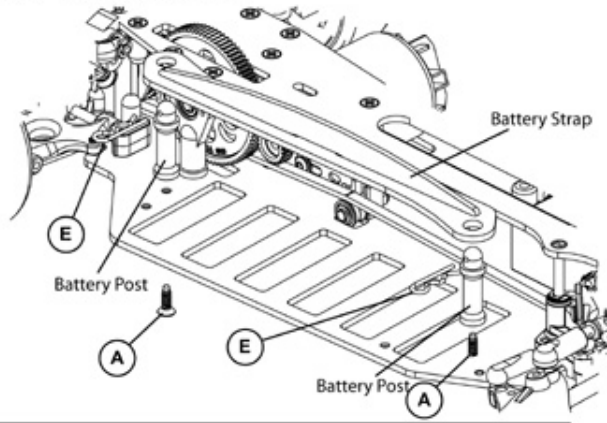

STICK PACK BATTERY MOUNTING

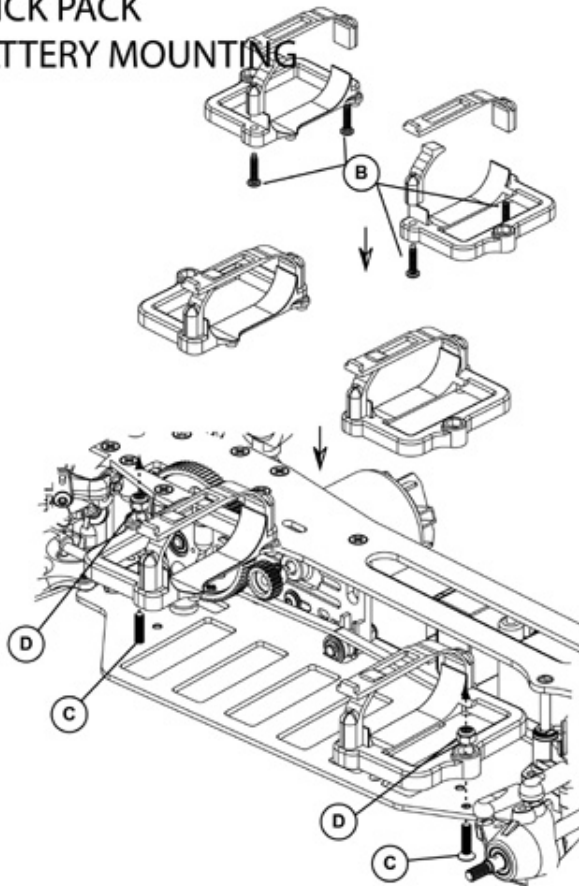

Schumacher

MISSION

MOUNTING BATTERY RETAINERS.

- A**  No4 3/8 Csk Head x 2
- B**  No4 1/2 Pan Head x 4
- C**  M3 x 12 Csk Head x 2
- D**  M3 Nyloc Nut x 2
- E**  "R" Clip x 2

Stick a strip of loop side along the edges marked with the dotted line.

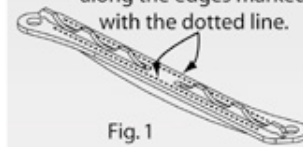
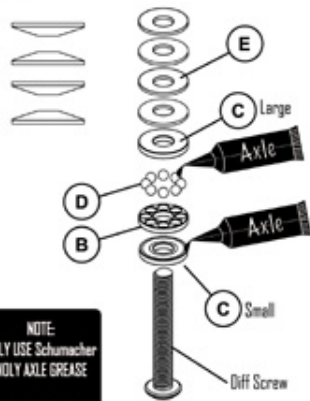

Fig. 1

TRACK TIP 20
If your saddle packs are a loose fit Help retain them with hook & loop strip. (see Fig.1)

1



2

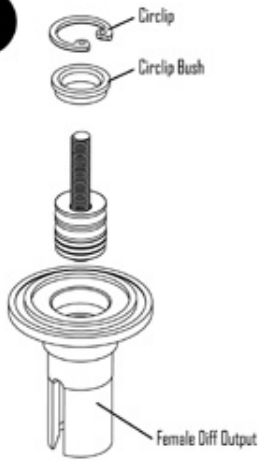

3

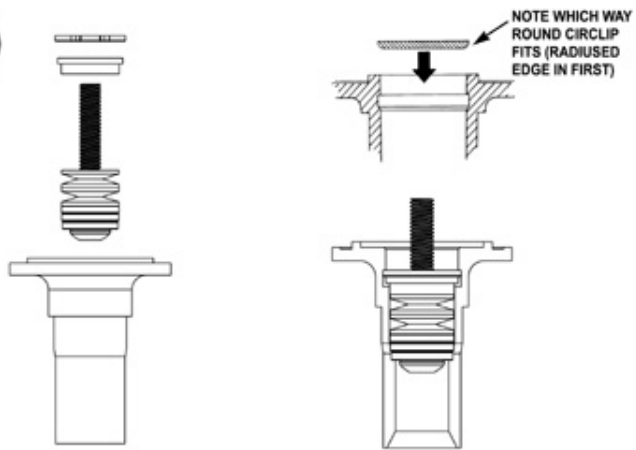

4

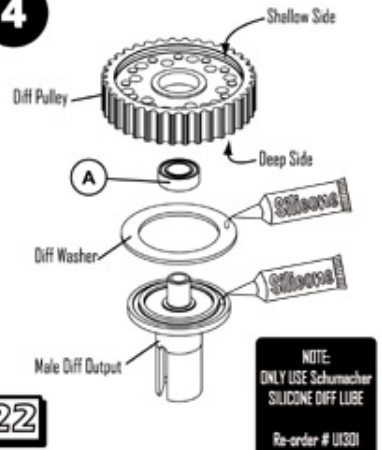

5

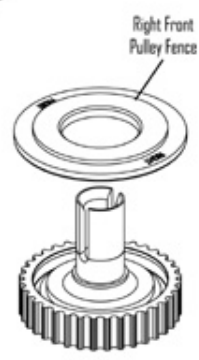

FRONT DIFFERENTIAL SERVICE

- A 5 x 9 x 3 Ball Race x 1
- B Thrust Race Cage x 1
- C Thrust Washer x 2 (1 x small, 1 x large)
- D 1/16th Dia Diff Ball x 8
- E Diff Disc Spring x 4

TRACK TIP 22
Only use Schumacher greases in your diffs. We have done many years of testing & we know it's the BEST!

22

7

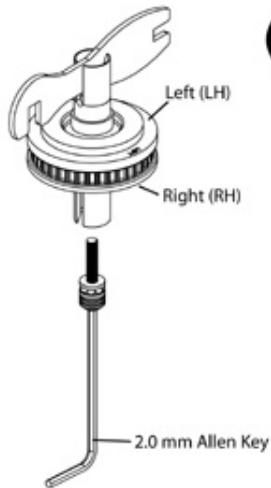

8



Diff Setting:
Tighten up fully and then
back off 180° (½ a turn).

Schumacher

MISSION

FRONT DIFFERENTIAL SERVICE

A

 M3 x 4 Grub Screw x 1

9

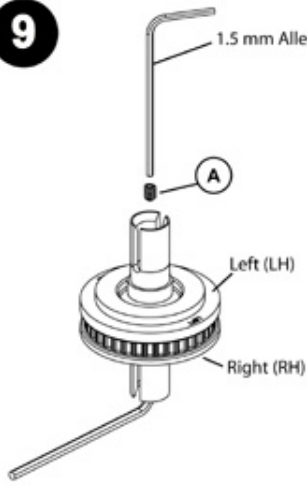

10

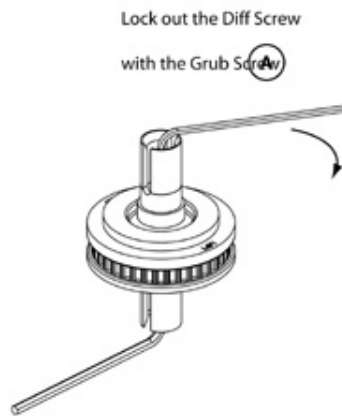

11

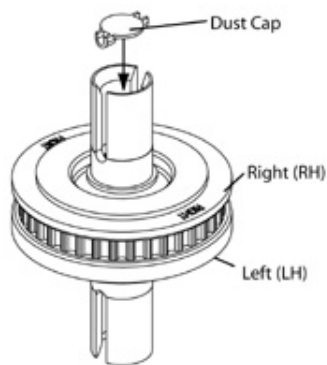

Final Assembly

TRACK TIP 23
Using the dust cap
will help give the
maximum life to
your diff... USE IT!

23

1

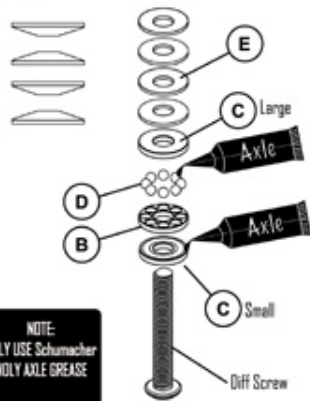

2



3

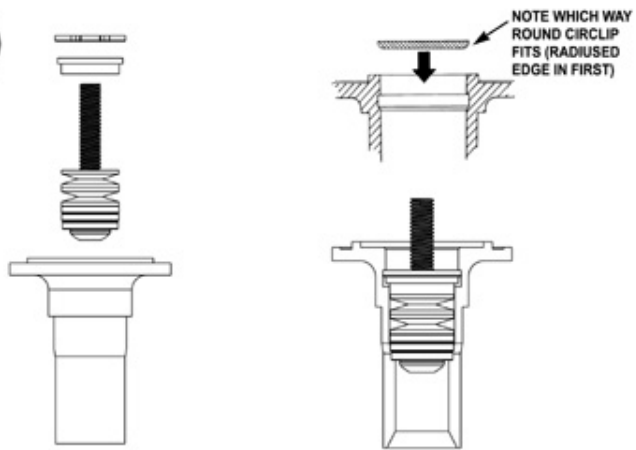

4

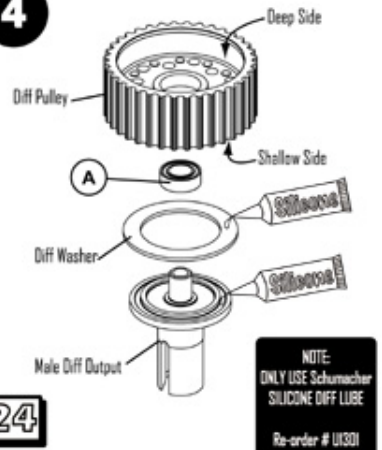

5

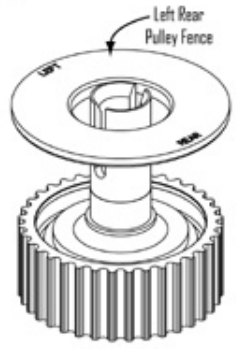

REAR DIFFERENTIAL SERVICE

- A 5 x 9 x 3 Ball Race x 1
- B Thrust Race Cage x 1
- C Thrust Washer x 2
(1 x small, 1 x large)
- D 1/16th Dia Diff Ball x 8
- E Diff Disc Spring x 4

TRACK TIP 24
Only use silicone grease on the large diff balls & moly grease on the small balls!

24

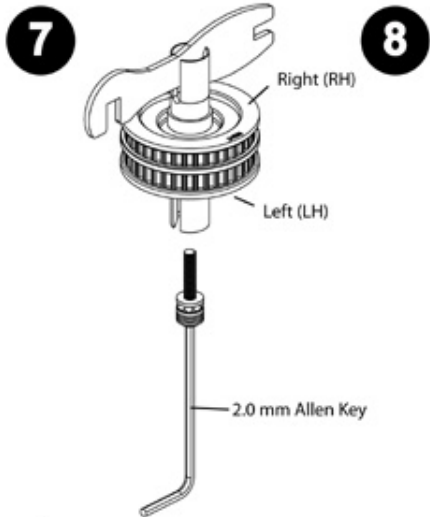

Diff Setting:
Tighten up fully and then
back off 180° (½ a turn).

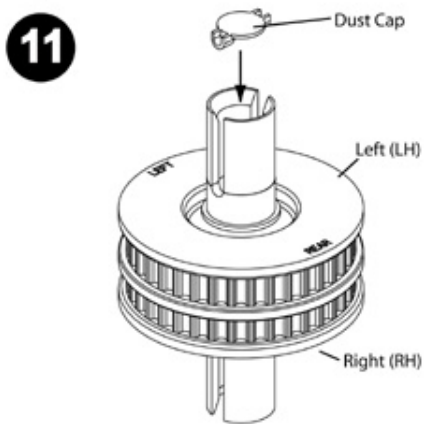
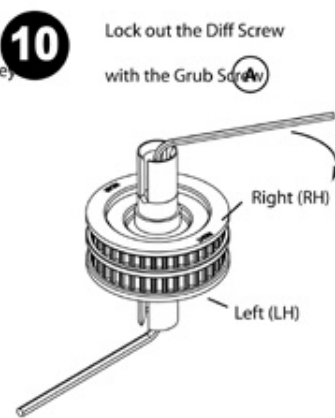
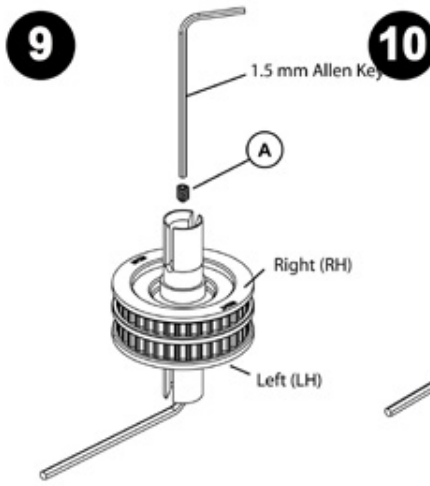

REAR DIFFERENTIAL SERVICE

- A  M3 x 4 Grub Screw x 1

TRACK TIP 25
Using the Schumacher "Fibre-Tool" to hold the output doesn't damage the output or your fingers!

Final Assembly

REAR TOE-IN/OUT (Out-board)

The rear toe-in is set by adjusting the turnbuckles at the rear of the car.

Toe-In = A less than B
 Toe-Out = A greater than B

2.5° toe-in each side is a good standard setting. This offers a good level of rear grip.

Reducing the rear toe-in offers better steering response and more straight line speed, but less stability

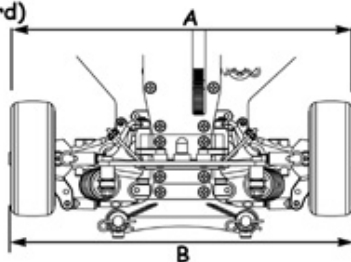

REAR TOE-IN (In-board)

The rear In-Board Toe-In is set by fitting the pivot blocks (see page 5 ● & ●). With the ridge facing in or out.

Facing in = 2° Toe-In
 Facing out = 0° Toe-In

0° Toe-In each side is the standard setting.
 2° Toe-In each side offers better rear end grip, but less steering response.

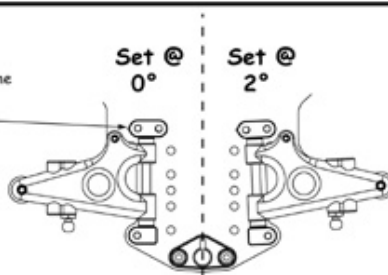

ANTI SQUAT & SUSPENSION DROOP

The car has 0° anti squat as standard. More anti squat will give more on power traction, but less off power traction, however too much will make the car unstable when turning into high speed corners. With 0° anti squat the steering will be precise & positive. On slippery tracks add anti squat.

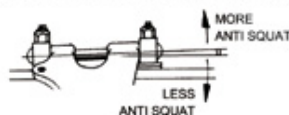

The suspension droop can be adjusted using the grub screw in the lower wishbones. Less droop improves steering response. More droop increases rear grip.

RIDE HEIGHT

In general always run the car as low as possible, without the chassis grounding out, as it rolls into corners.

Run the front 0.5mm to 1.0mm lower than the rear, to give more steering.

A good starting point is 5.5mm at the front and 6.0mm at the rear.

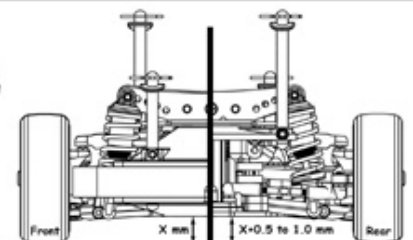

WHEELBASE (set on REAR wishbones)

The length of the wheelbase is set by fitting the spacers "G" (see page 5 ●). In different positions.

In front of the wishbone = Long. Either side of the wishbone = Medium. Behind the wishbone = Short

Use spacers to maintain the wheelbase length after adjusting the Castor or Toe-In/Out. In general a longer wheelbase will offer more steering.

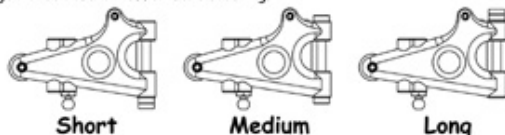

26

Schumacher

mission

TRACK SETTINGS AND GEAR RATIO CHARTS

PULLEYS 17/36

Maximum Tooth Sum = 124

Minimum Tooth Sum = 101

2.12 : 1 INTERNAL RATIO

	95	92	89	86	83
15	13.41	12.99	12.56	12.14	
16	12.57	12.18	11.78	11.38	
17	11.83	11.46	11.09	10.71	
18	11.18	10.82	10.47	10.12	9.76
19	10.59	10.25	9.92	9.59	9.25
20	10.06	9.74	9.42	9.11	8.79
21	9.58	9.28	8.97	8.67	8.37
22	9.14	8.86	8.57	8.28	7.99
23	8.75	8.47	8.19	7.92	7.64
24	8.38	8.12	7.85	7.59	7.32
25	8.05	7.79	7.54	7.28	7.03
26	7.74	7.49	7.25	7.00	6.76
27	7.45	7.22	6.98	6.75	6.51
28	7.18	6.96	6.73	6.50	6.28
29	6.94	6.72	6.50	6.28	6.06
30		6.49	6.28	6.07	5.86
31			6.28	6.08	5.87
32				6.09	5.89

PULLEYS 20/36

Maximum Tooth Sum = 131

Minimum Tooth Sum = 108

1.8 : 1 INTERNAL RATIO

	95	92	89	86	83
15	11.40				
16	10.69	10.35			
17	10.06	9.74			
18	9.50	9.20			
19	9.00	8.72	8.43		
20	8.55	8.28	8.01		
21	8.14	7.89	7.63		
22	7.77	7.53	7.28	7.04	
23	7.43	7.20	6.97	6.73	
24	7.13	6.90	6.68	6.45	
25	6.84	6.62	6.41	6.19	5.98
26	6.58	6.37	6.16	5.95	5.75
27	6.33	6.13	5.93	5.73	5.53
28	6.11	5.91	5.72	5.53	5.34
29	5.90	5.71	5.52	5.34	5.15
30	5.70	5.52	5.34	5.16	4.98
31	5.52	5.34	5.17	4.99	4.82
32	5.34	5.18	5.01	4.84	4.67

TRACK SETTINGS

FRONT TOE-IN (Out-board)

The front toe-in is set by adjusting the steering trackrod turnbuckles.

Toe-In = A less than B
Toe-Out = A greater than B

Toe-in will give a more stable car, but will give less sharp turn in. We recommend to start at about 1° each side. Maximum 2° each side.

Toe-out will give the opposite, less stability with sharper turn in to the corners.

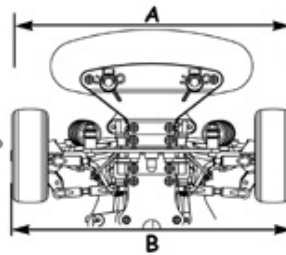

FRONT TOE-OUT (In-board)

The front In-board toe-out is set by fitting the front strap (see page 90) with the 2° mark up or down.

2° mark showing (up) = 0°
2° not showing (down) = 2° toe-out.

With the In-board position set to 2° the steering will be smooth and progressive, when set to 0° the steering is more aggressive.



SPRINGS

The spring rate controls the suspension stiffness.

Fit spring spacers only to change the ride height. They DO NOT alter the suspension stiffness. On slippery or bumpy tracks use soft to medium rate springs, on flat or high grip tracks run medium to hard rate springs.

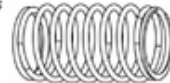

FRONT CASTOR

The front castor can be altered by moving the two washers on the top wishbone pivot pin. Less castor will give a quicker steering response, but could lead to power on understeer. More castor will give the opposite, slightly slower turn in, but more power on steering.

11° = 2 washers at rear.

8.5° = 1 washer each side.

6° = 2 washers at front.

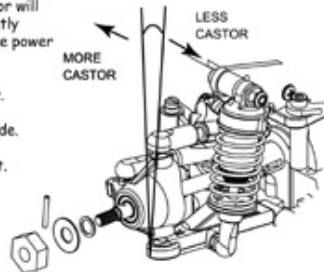

LOWER SHOCK POSITION

Inner (standard) position is best for most tracks & conditions. The outer position is good on VERY high grip tracks.



SHOCK BRACKETS

Vertical shock absorbers make the car react sharply to driver inputs. A laydown shock offers a softer feel to the driver.



UPPER SUSPENSION MOUNT

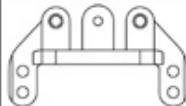

The upper (standard) hole makes the car smooth and predictable. The lower hole can offer better grip, but with a much less predictable breakaway.

HUB CARRIER

Position 1 offers an aggressive initial steering response. Position 2 (standard) offers a softer initial steering response.

Use hole 1 for a faster, more aggressive steering response and more lock. Use hole 2 for smoother more proportional steering. Hole 2 is generally better on high grip tracks.

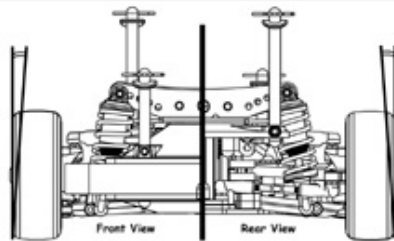

FRONT & REAR CAMBER

Car as standard will have 4° negative camber (the top of the wheels lean inward). Set the camber to 1° negative by adjusting the top wishbone turnbuckle. To reduce camber look at wheel face on & turn allen key anti-clockwise as shown above - This is the same for all four wheels. With maximum camber (4°) the car will have high levels of grip, but there may be the possibility of sudden breakaway in corners. Reducing the camber gives a more progressive slide, but may give less grip. See set up sheet.

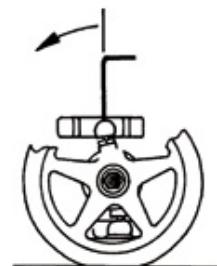
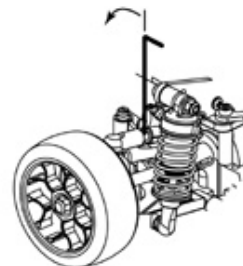

MISSION

U2252
 Gear Adaptor.
 CNC machined purple alloy Schu/Kimb spur gear adaptor.



U2151
 Steel Driveshafts.
 Metal U.J.s that are stronger and still include Schumachers revolutionary blade drive system.



U2096
 Aerial Mount.
 Purple Chrome Aerial Mount. Jazzy version of standard car equipment.



U2155
 Purple Alloy M4 Nyloc Wheel Nuts.
 Lightweight flanged purple wheel nuts.

U2297
 Threaded Shock Bodies (Pk4)
 Purple Alloy shock bodies and collars that give ultra fine ride-height adjustment.



U2188
 Alloy Shock Seal Housings (pr).
 Purple CNC housing. Offers strength and a super smooth operation.



U2462
 Purple Alloy Diff Mounts.
 CNC Machined, offers accurate assembly of the diffs.



U2463
 Purple Alloy Layshaft Mounts.
 CNC Machined, offers accurate assembly of the layshaft and the pulleys.

U2469
 One Way Front Drive Unit.
 For better "on-power" steering, higher corner speed and increased efficiency.



U2460 (20t)
 20t & 17t Alloy Layshaft Pulley.
 Long lasting, super strong pulley for low maintenance, high performance use.



U2461 (17t)

IMPORTANT SAFETY NOTES

- This product is not suitable for children under the age of 14, without the direct supervision of an adult.
- Select an area for assembly that is away from reach of very small children. The parts are small and can be swallowed by children causing choking and possible internal injuries.
- Exercise care when using any hand tools and sharp instruments during construction.
- Carefully read all manufacturers warnings and cautions for any parts used in the construction & use of your **mission**.

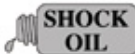

POINTS WHERE SHOCK OIL SHOULD BE APPLIED



POINTS WHERE AXLE GREASE SHOULD BE APPLIED
(It will reduce friction & assure smooth movement)



POINTS WHERE SILICONE GREASE SHOULD BE APPLIED

Do not use excessive force when tightening the selftapping screws, or you may strip the thread in the plastic. It is recommended to stop tightening it when the threaded part on the screw goes into the plastic part and you feel some resistance from the tightening.



Good



Over tighten and you may strip the thread in the plastic

In line with our policy of continuous development the exact specification of the kit may vary.

MISSING OR DEFECTIVE PARTS

In the unlikely event of any problems with your new kit you should contact the model shop where you purchased, quoting part number, bag number and batch

FOR BEST PERFORMANCE, IT IS VERY IMPORTANT THAT GREAT CARE IS TAKEN TO ENSURE THE FREE MOVEMENT OF ALL PARTS.

ADDITIONAL ITEMS REQUIRED EQUIPEMENTS NECESSAIRES ACCESORIOS ADICIONALES BENÖTIGTES ZUBEHÖR NÖDVÄNDIGA TILLBEHÖR ACCESSORI NECESSARI

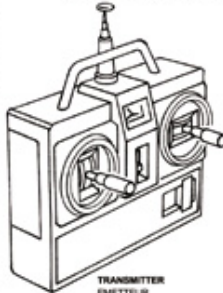

TRANSMITTER

EMETTEUR
EMISORA
FERNSTEUERSENDER MIT MINDESTENS 2-KANÄLEN
RADIOSTYRNING MED MINST 2-KANALER
TRASMITTENTE 2 CANALI

8 PEN CELLS (FOR TRANSMITTER)
8 PILAS PARA LA EMISORA
8 MIGNON-ZELLEN FÜR SENDEK
8 ST BATTERIER FOR SANDAREN
8 BATTERIE PER TRASMITTENTE

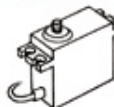

STEERING SERVO
SERVO DE DIRECTION
SERVO DE DIRECTION
LENKSERVO
SERVO FÖR STYRNING
SERVOCOMANDO DELLO STERZO



RECEIVER
RECEPTEUR
RECEPTOR
EMPFÄNGER
MOTTAGARE
RICEVENTE

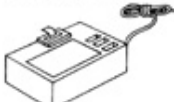

MOTOR & PINION
MOTEUR ET PIGNON
MOTOR Y PIGNON
MOTOR & MOTORHITZEL
ELMOTOR & PIGNON
MOTORE E PIGNONE



NI-CAD STICK PACK



SADDLE BATTERY PACK



SPEED CONTROLLER
VARIABLEUR ELECTRONIQUE
CONTROL DE VELOCIDAD
FAHRTENREGLER
ELEKTRONISKT FARTREGLAGE
VARIATORE ELETTRONICO DI VELOCITA



NI-CAD CHARGER
CHARGEUR D'ACCUS
CARGADOR DE BATERIAS
LADGERÄT
LADGARE FOR ACKPÅKET
CARICABATTERIE

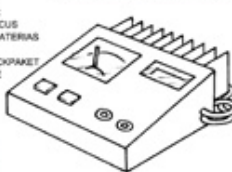

PAINT FOR BODYSHELL
BOISSE DE PEINTURE POUR LA CARROSSERIE
PINTURA CARROCERIA
LEXANFÄRBN FÜR DIE KAROSSERIE
LEXANFÄRO TILL KAROSSEN
VERNICE SPRAY PER POLICARBONATO



TOOLS REQUIRED

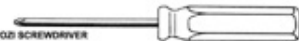

POZ SCREWDRIVER
TOURNEVIS PHILIPS
ATORNILLADOR DE ESTRELLA
KREUZSCHLITZ-SCHRAUBENZIEHER
STJÄRNKRUVNÄSSEL
CACCIAVITE A CROCE



7mm AF SOCKET SPANNER
CLÉ DE 7mm À PIPE OU EMBANCHÉE
LLAVE DE TUBO DE 7mm
STECKSCHLÜSSEL 7mm
7mm HYLBYCKEL
CHAVE A TUBO DA 7mm



5.5mm AF SOCKET SPANNER
CLÉ DE 5.5mm À PIPE OU EMBANCHÉE
LLAVE DE TUBO DE 5.5mm
STECKSCHLÜSSEL 5.5mm
5.5mm HYLBYCKEL
CHAVE A TUBO DA 5.5mm



FLAT SCREWDRIVER
TOURNEVIS PLAT
ATORNILLADOR PLANO
SCHRAUBENZIEHER
SKRUVNÄSSEL
CACCIAVITE A TAGLIO



6mm DRILL BIT
OUTIL DE FORAGE 6mm
BROCA DE 6mm
BOHRER 6mm
6mm BORR
PUNTA DA TRAPANO DA 6mm

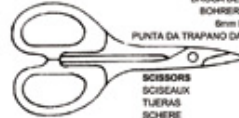

SCISSORS
SCISEAUX
TIJERAS
SCHERE
SAK
FORBICE



PLIERS
PINCES
ALICATES
ZANGE
TANG
PINZA A BECCHE SOTTILI



SCALPEL
CUTLER
CUCHILLA
SCHARPF MESSER
HOBBYKNIV
CUTTER

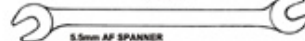

5.5mm AF SPANNER
CLÉ PLATE DE 5.5mm
LLAVE FLJA 5.5mm
GABELSCHLÜSSEL 5.5mm
5.5mm FAST NYCKEL
CHAVE INGLESE DA 5.5mm

RULER MILLIMETRES

