



1/10th Scale Nitro Truck • Includes R10 (3.0cc) Engine

Instruction Manual v 1.0



Schumacher Racing
73 Tenter Road
Moulton Park
Northampton
NN3 6AX
ENGLAND



www.racing-cars.com

Schumacher USA Inc
6302 Benjamin Road
Suite 404
Tampa
Florida 33634
U.S.A

S1175



IMPORTANT SAFETY NOTES

1. This product is not suitable for children under 14 years of age unless supervised by an adult.
2. Select an area for assembly that is away from reach of small children. The parts are small and can be swallowed by children causing choking and possible internal injuries.
3. Shock fluids, grease and adhesives should be kept out of children's reach. They are not toxic, but were not intended for human consumption.
4. Exercise care when using any hand tools, sharp instruments and power tools during construction.
5. Carefully read all manufacturers warnings and cautions for any glues or paints that may be used for assembly purposes.

Do not use excessive force when tightening the self-tapping screws, or you may strip the thread in the plastic. It is recommended to stop tightening it when the threaded part on the screw goes into the plastic part and you feel some resistance from the tightening. Screws can be made easier to tighten if a drop of oil is used.



Good



Over tighten and may strip the thread in the plastic

ADDITIONAL ITEMS REQUIRED

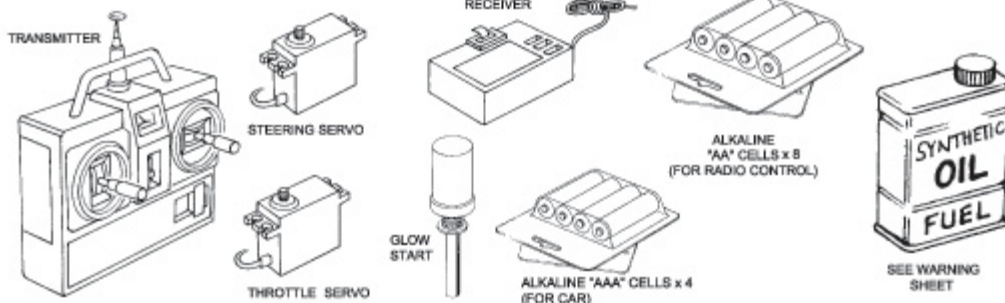

FOR BEST PERFORMANCE, IT IS VERY IMPORTANT THAT GREAT CARE IS TAKEN TO ENSURE THE FREE MOVEMENT OF ALL PARTS.

ADDITIONAL TOOLS REQUIRED

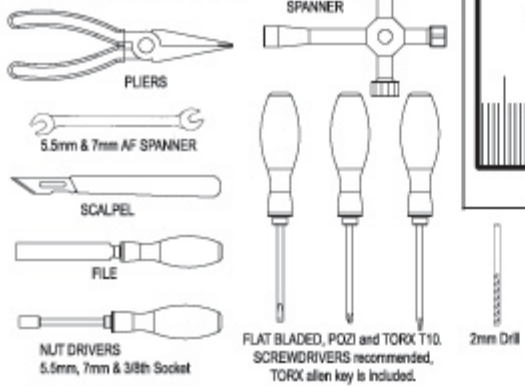

In line with our policy of continuous development the exact specification of the kit may vary. In the unlikely event of any problems with your kit please contact the model shop where you purchased it.

BEFORE STARTING TO INSTALL THE RADIO GEAR, CONNECT UP SERVOS, BATTERY, SWITCH AND RECEIVER. SET TRIMS ON THE TRANSMITTER TO NEUTRAL AND TURN THE RADIO AND CAR ON. TEST BOTH SERVOS WORK



1

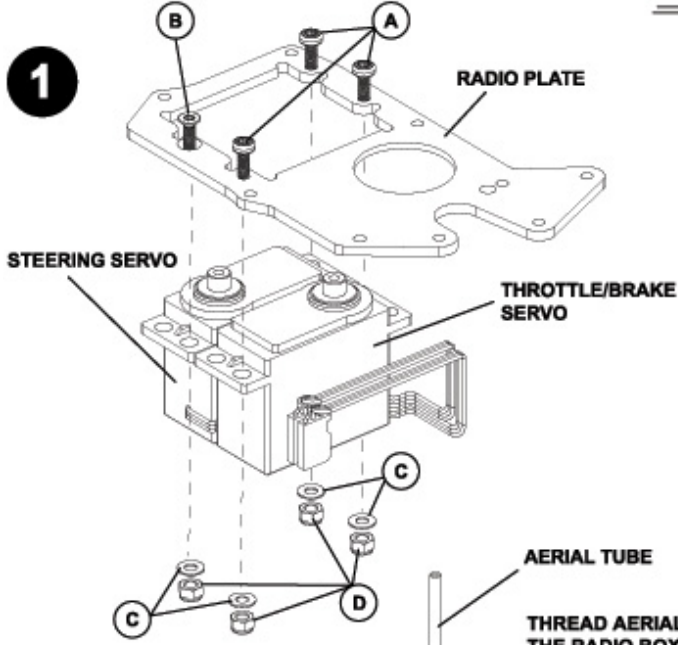

RADIO INSTALLATION

A M3 x 10 Pan TORX Head x 5

B M3 x 10 Csk TORX Head x 1

C M3 Steel Washer x 4

D M3 Nyloc Nut x 4

2

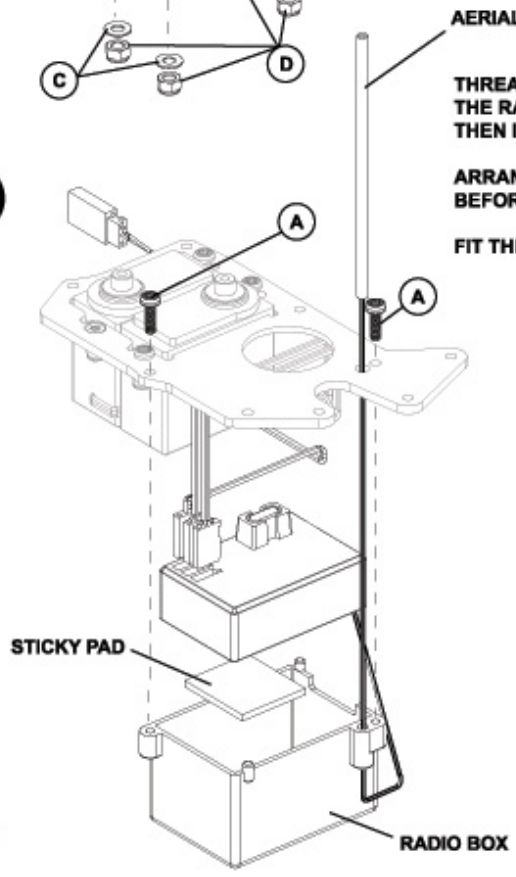

THREAD AERIAL WIRE THROUGH THE RADIO BOX AND RADIO PLATE THEN INTO THE AERIAL TUBE

ARRANGE WIRES INTO THE RADIO BOX BEFORE SCREWING THE RADIO PLATE DOWN

FIT THE GROMMET

3

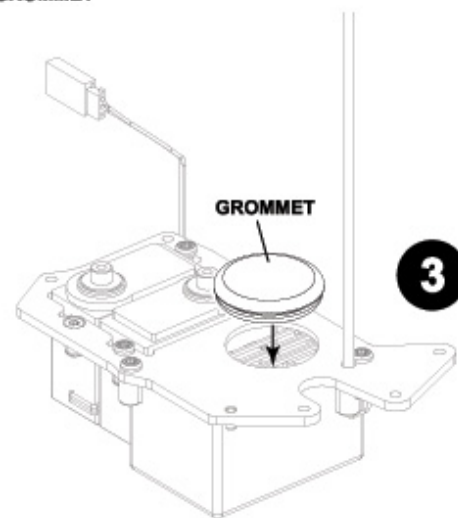

1



4 INSTALL SERVOS

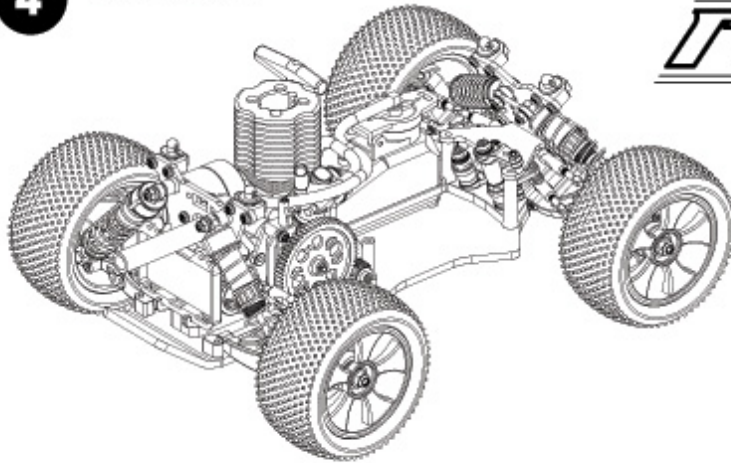

**RADIO
INSTALLATION
Continued**

- (A)**  M3 x 16 Pan TORX Head x 3
- (B)**  M3 x 10 Pan TORX Head x 2

5

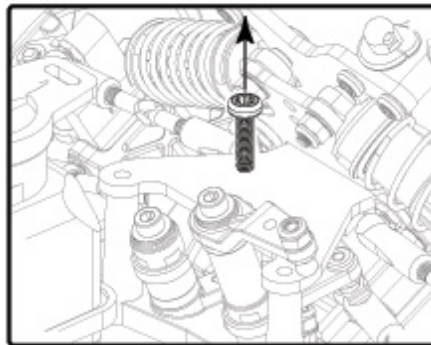

REMOVE SCREW SHOWN BEFORE
INSTALLATION OF RADIO EQUIPMENT.

6

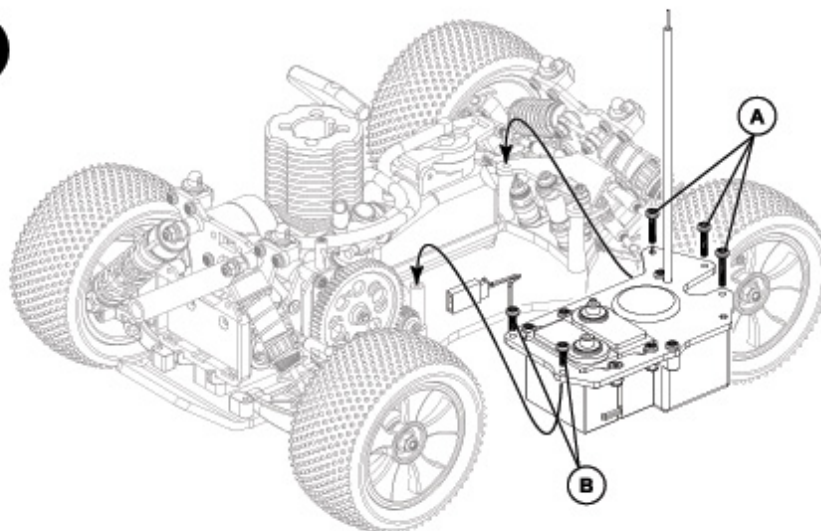

7

SCREWS SUPPLIED
WITH SWITCH

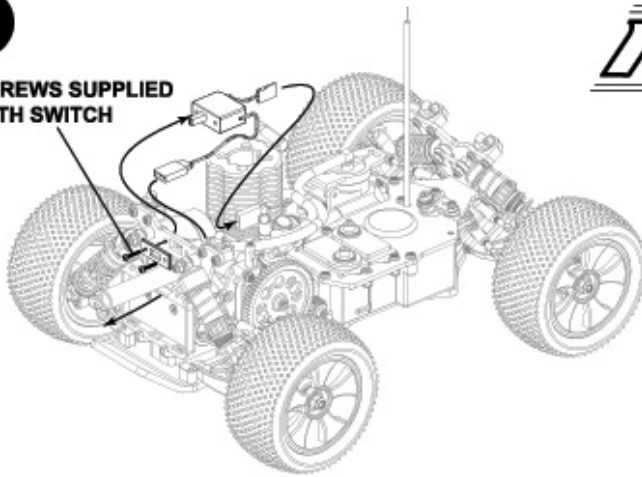

**RADIO
INSTALLATION
Continued**

A



M3 x 10 Pan TORX Head x 2

8

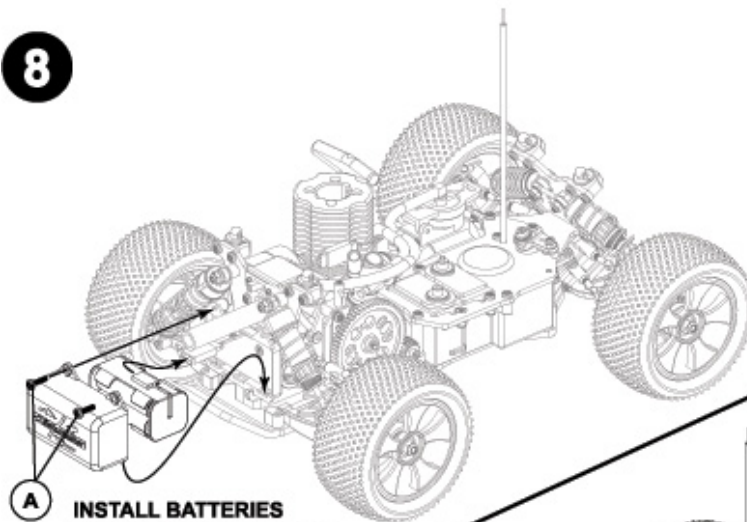

A

INSTALL BATTERIES
AND CONNECT BATTERY
BOX TO SWITCH.

9

NOW CHECK RADIO INSTALLATION
WORKS CORRECTLY AGAIN.

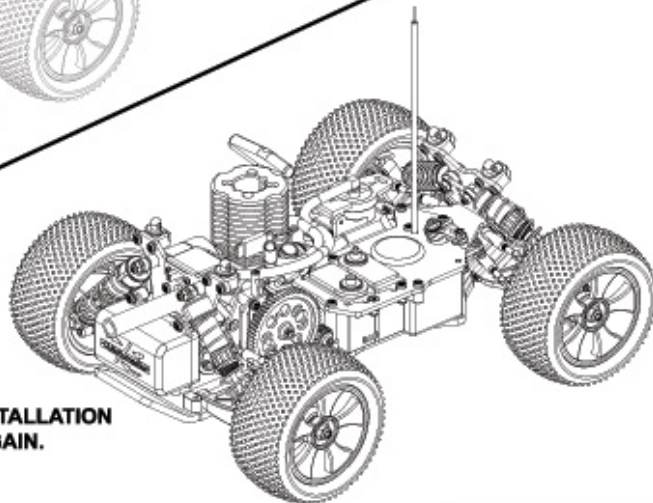

3

Schumacher

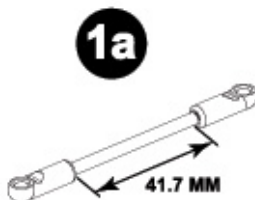
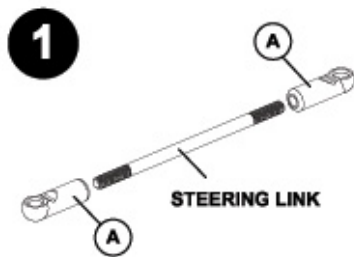

STEERING LINK



Ball Socket x 2



Ball Stud Ultra Short M3 x 1

2 CHOOSE THE CORRECT HORN FOR YOUR SERVO.
SA = SANWA/AIRTRONICS
FU = FUTABA
SH = SCHUMACHER/HITEC

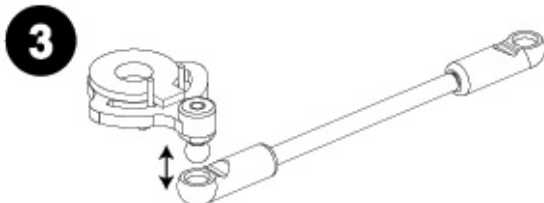

SCREW SUPPLIED WITH SERVO

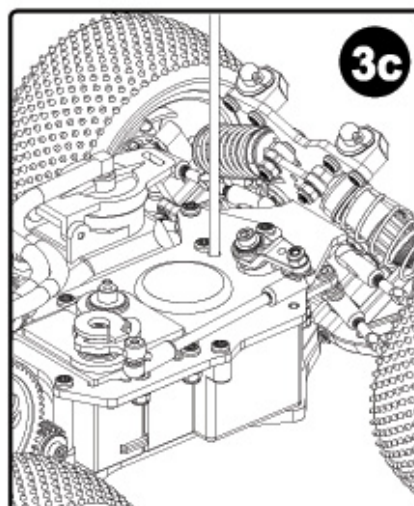
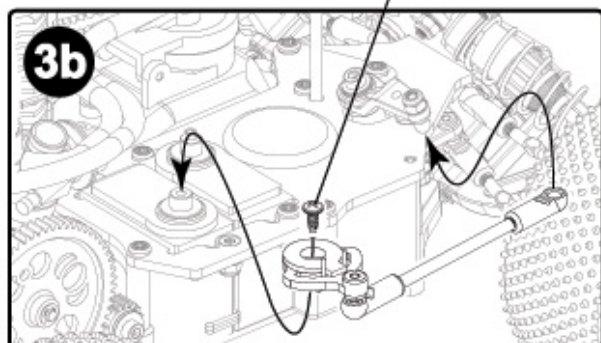

ASSEMBLE HORN SO WHEELS POINT DEAD AHEAD AT NEUTRAL

1

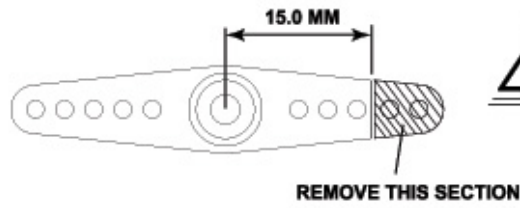

THROTTLE AND BRAKE LINKS

A 
Ball Socket x 1

B 
No2 3/8 Pan Head x 1

C 
Collar & grub screw x 2

D 
Rubber Tube x 1

2

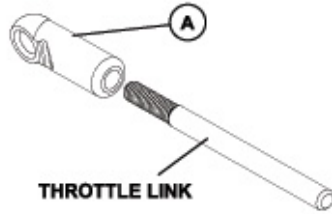

3

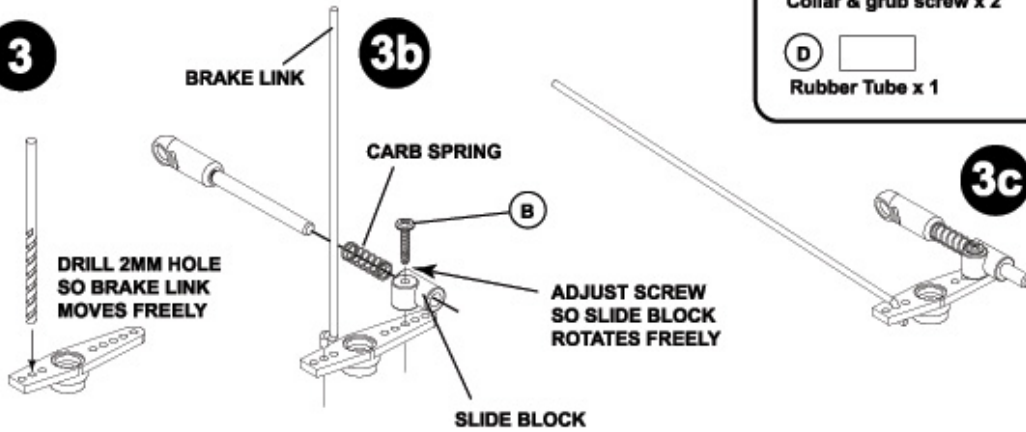

4

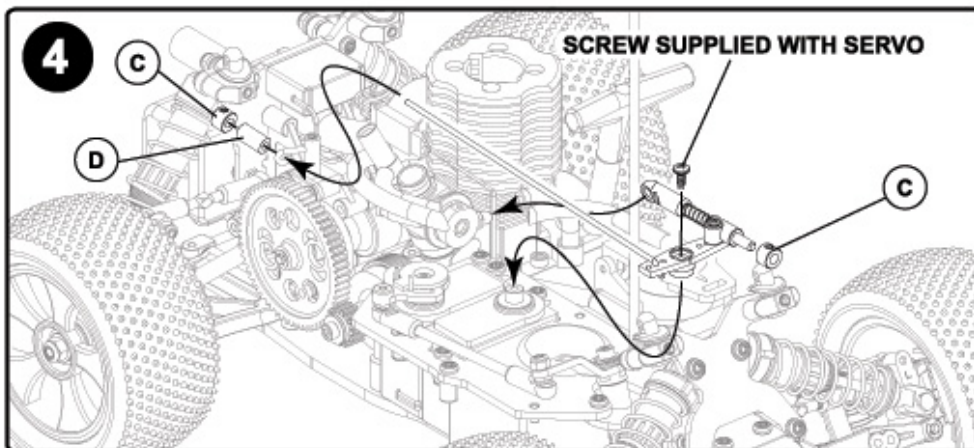

5

SETTING LINKS

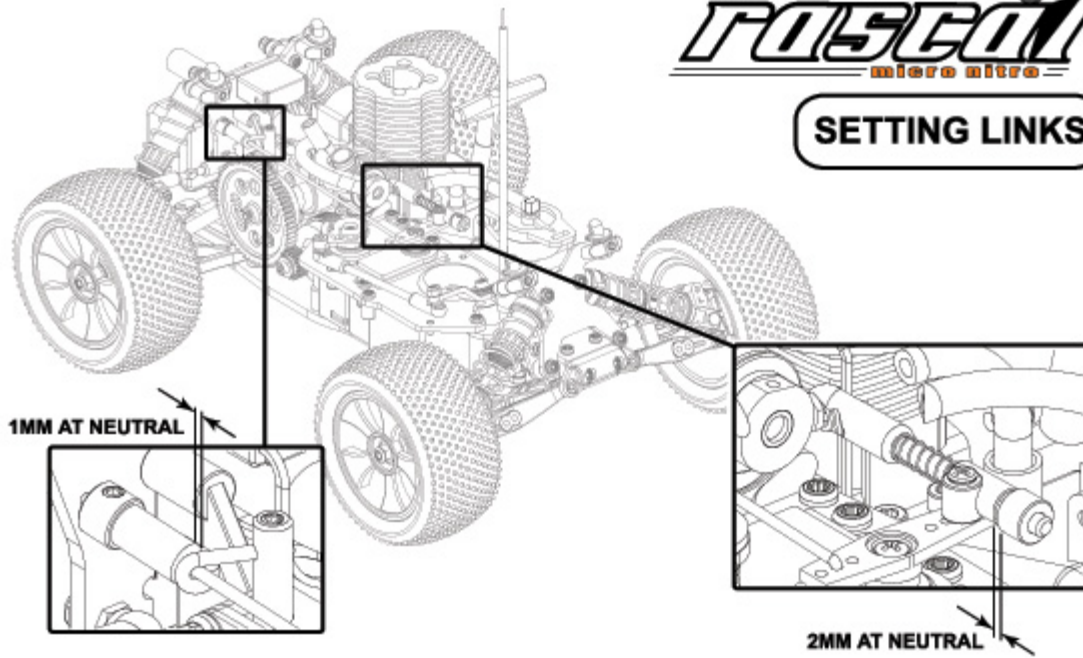

SAFETY RETURN SPRING

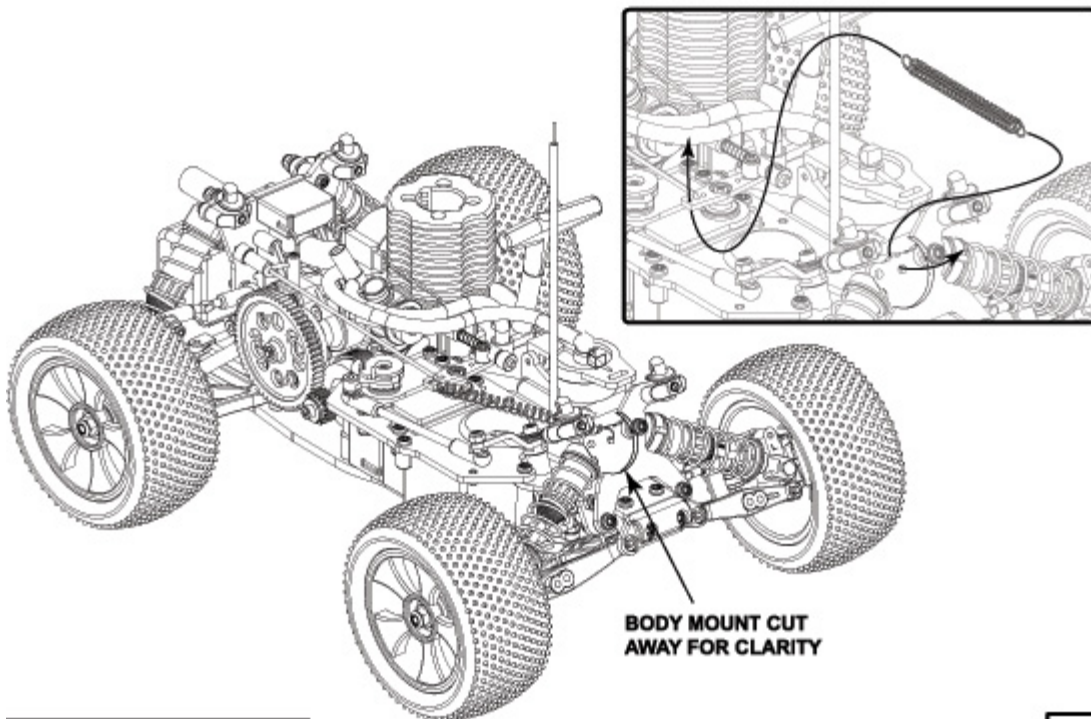

1



AIR FILTER

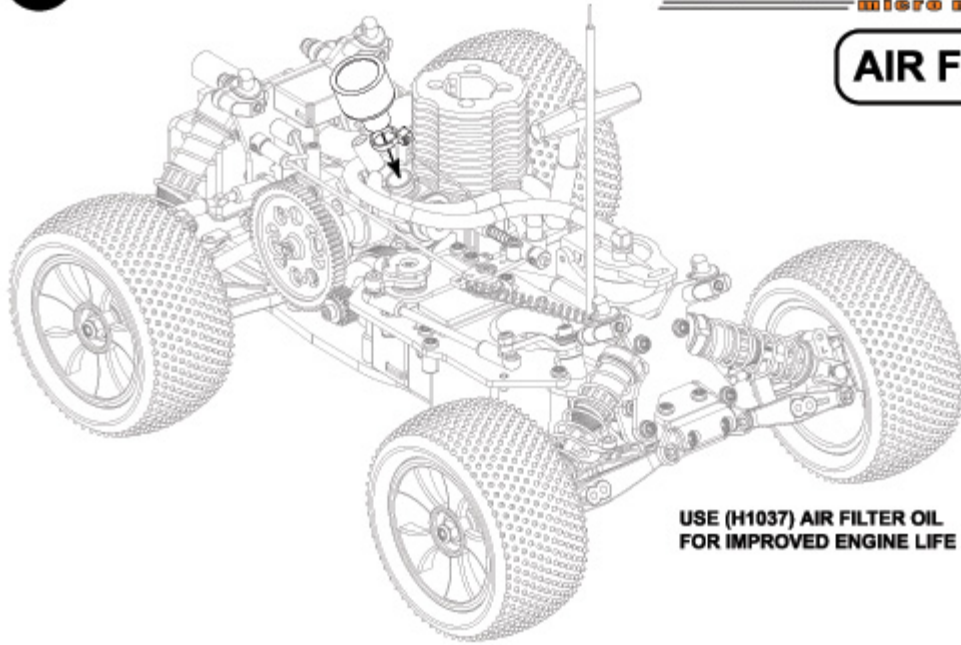

**USE (H1037) AIR FILTER OIL
FOR IMPROVED ENGINE LIFE**

2

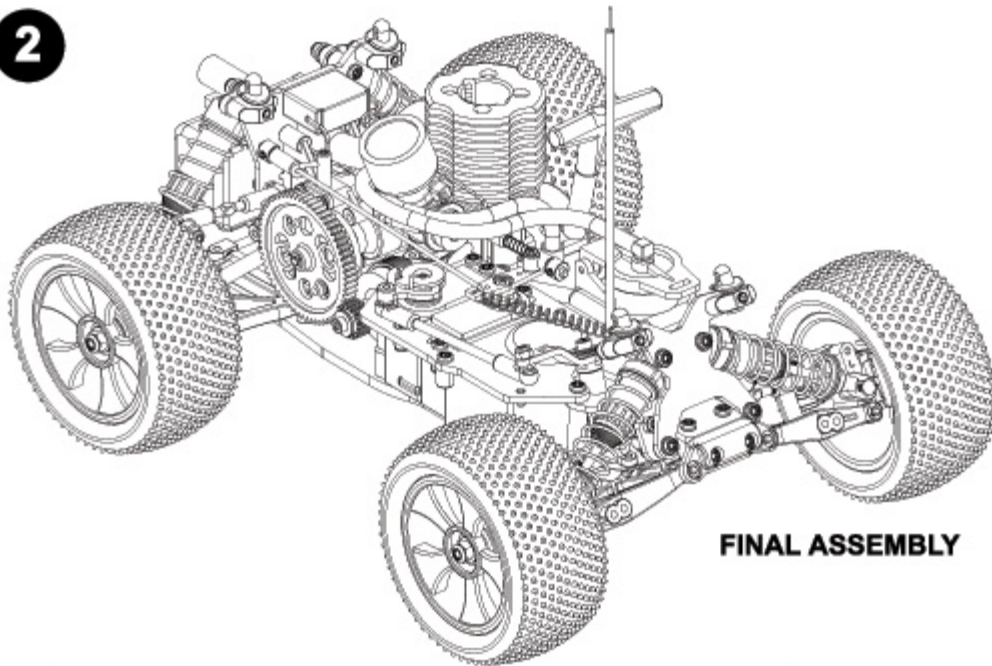

FINAL ASSEMBLY

7



1 FILL FUEL TANK

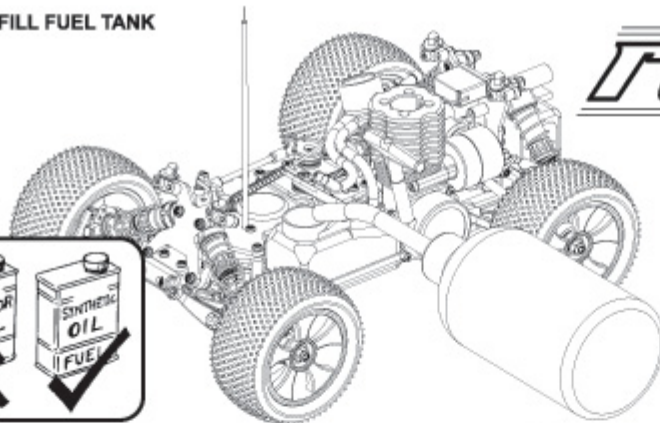
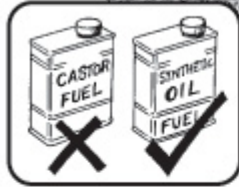

STARTING ENGINE

WE STRONGLY RECOMMEND MODEL TECHNICS DYNAGLOW, JETS, BLUE THUNDER, MAGNUM OR O'DONNELL 16-25% FUEL

2 PRIMING ENGINE

TURN ON TRANSMITTER. SWITCH ON RECEIVER. ENSURE BATTERIES ARE FULLY CHARGED.



ENSURE THROTTLE TRIM IS AT NEUTRAL, CHECK THROTTLE, BRAKE & STEERING ACTION.

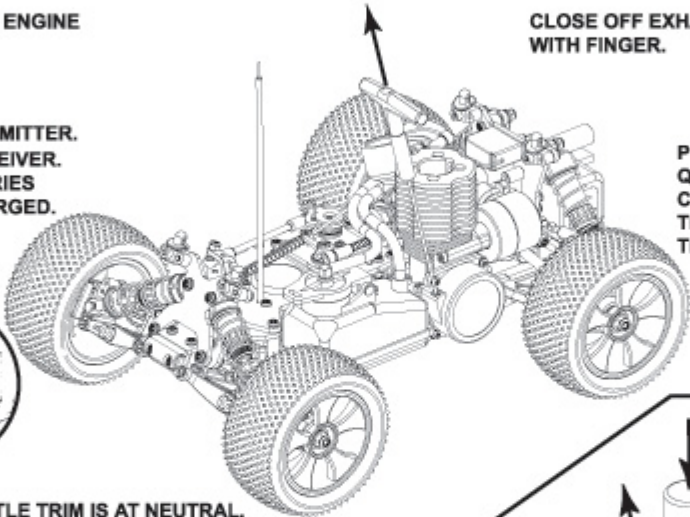

CLOSE OFF EXHAUST WITH FINGER.



PULL STARTER IN SHORT, QUICK BURSTS UNTIL FUEL CAN BE SEEN ENTERING THE CARBURETOR THEN THREE MORE PULLS.

HOLD GLOW START ONTO GLOW PLUG

3 STARTING ENGINE

PULL STARTER IN QUICK SHORT BURSTS UNTIL ENGINE STARTS

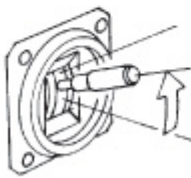

GENTLY REV THE ENGINE THEN REMOVE THE GLOW START

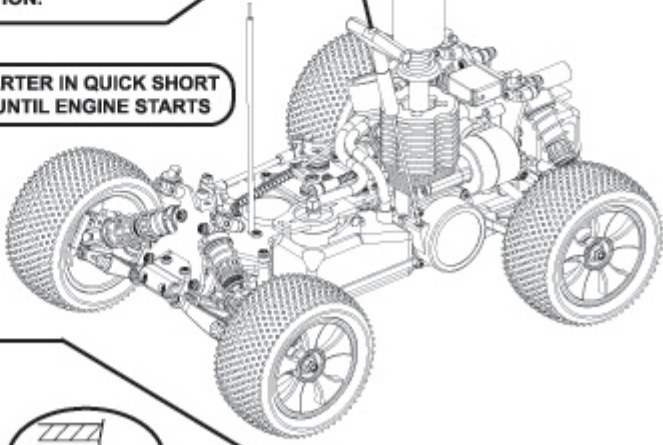

4 STOPPING ENGINE

WARNING:

ENGINE AND SILENCER WILL BE VERY HOT DO NOT TOUCH FOR SEVERAL MINUTES



ENSURE ENGINE IS AT IDLE BEFORE STOPPING. STOP ENGINE BY BLOCKING THE EXHAUST.



TRANSMITTER
ZERO/NEUTRAL



ENGINE STALLS = SCREW THROTTLE STOP SCREW CLOCKWISE TO INCREASE REVS



IDLE SPEED SETTING



CAR DOES NOT MOVE AND SOME SMOKE = OK



0.75MM SLIDE OPEN

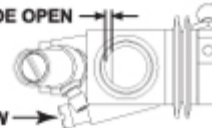

IDLE SCREW

SET IDLE SPEED AS HIGH
AS POSSIBLE WITHOUT
THE CAR EDGING FORWARD



CAR EDGES FORWARD = SCREW THROTTLE STOP SCREW ANTI-CLOCKWISE TO LOWER REVS



TRANSMITTER - STOP-GO
(MAX ACCELERATION)



TOO MUCH SMOKE AND SLOW ACCELERATION (TOO RICH)
SCREW LOW SPEED MIXTURE SCREW CLOCKWISE



LOW SPEED MIXTURE SETTING



SOME SMOKE AND GOOD ACCELERATION = OK



BETWEEN 4 1/4 AND 3 TURNS OPEN
(ANTI-CLOCKWISE)
FROM FULLY CLOSED

LOW SPEED
MIXTURE SCREW

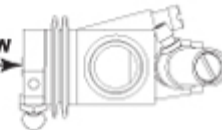

CAR EDGES FORWARD THEN STALLS
(TOO LEAN) SCREW LOW SPEED MIXTURE SCREW ANTI-CLOCKWISE



TRANSMITTER
MAX FULL SPEED



TOO MUCH SMOKE AND SLOW SPEED (TOO RICH)
SCREW HIGH SPEED MIXTURE SCREW CLOCKWISE



HIGH SPEED MIXTURE SETTING



SOME SMOKE AND GOOD SPEED = OK



BETWEEN 4 AND 2
TURNS OPEN
(ANTI-CLOCKWISE)
FROM FULLY CLOSED

HIGH SPEED
MIXTURE SCREW

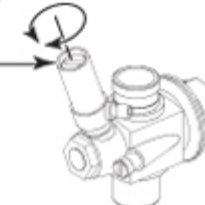

TOO LITTLE SMOKE AND SLOW SPEED (TOO LEAN)
SCREW HIGH SPEED MIXTURE SCREW ANTI-CLOCKWISE



IF THE CAR BEGINS TO LOSE PERFORMANCE
AFTER A FEW MINUTES IT IS PROBABLY
OVERHEATING (TOO LEAN). YOU MUST STOP
AND SCREW THE HIGH SPEED MIXTURE
SCREW 1/4 TURN ANTI-CLOCKWISE

DO NOT ALLOW THE NOISE TO ANNOY OTHERS
DO NOT OPERATE THE "CAR" ON THE PUBLIC HIGHWAY
DO NOT OPERATE THE "CAR" IN A CONFINED SPACE OR CROWDED AREA
DO NOT RUN ENGINE WITHOUT AIR FILTER - SERIOUS DAMAGE WILL RESULT
DO NOT ALLOW THE TRANSMITTER OR RECEIVER BATTERIES TO RUN FLAT



TROUBLE SHOOTING

RUNNING ENGINE IN FROM NEW

To ensure your engine has a long life the engine needs to be "run in" before being "raced".

Run the car for 2 or 3 tank fulls, at a rich

Carb setting on half throttle, do not use full throttle

AFTER RUNNING IN

After "running in" is complete, and you have re-tuned the high and low end mixture screws for maximum power, you may need to reset the idle speed to prevent the car from "creeping" forward at neutral. This must be done with the IDLE SPEED SCREW on the carburettor NOT with the throttle trim on the radio, which will only apply the brakes. Applying the brakes will leave the clutch dragging and lead to over-heating.

SEE PAGE NINE FOR HOW TO SET YOUR IDLE SPEED.





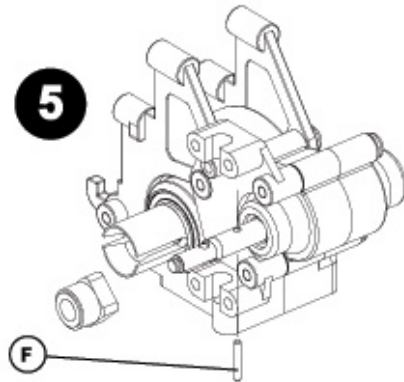
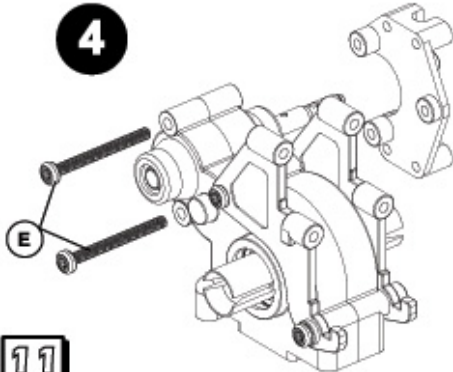
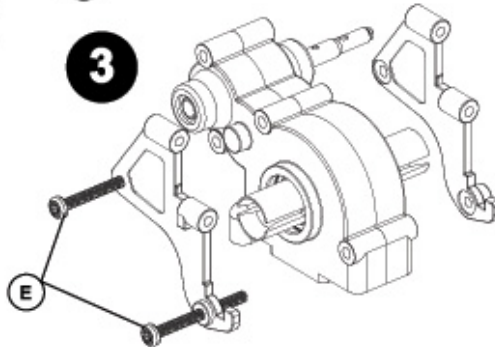
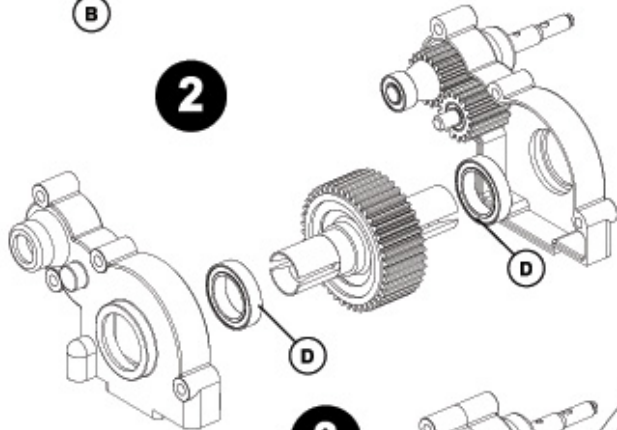
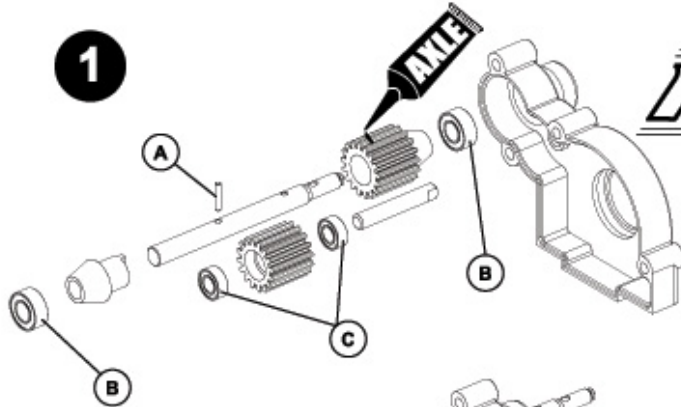

The following information will help solve any problems when running and maintaining your car

PROBLEM	CAUSE	REMEDY
ENGINE DOES NOT START	FUEL TANK EMPTY, ENGINE NOT PRIMED FLAT GLOW BATTERY OR DEAD GLOW PLUG CLOGGED AIR FILTER OVER PRIMED, CYLINDER FLOODED WITH FUEL INCORRECT CARBURETTOR ADJUSTMENT INCORRECT LINKAGE ADJUSTMENT WORN ENGINE - PISTON LINER	FILL TANK AND REPRIME ENGINE RECHARGE BATTERY AND/OR REPLACE PLUG CLEAN OR REPLACE AIR FILTER REMOVE GLOW PLUG THEN TURN ENGINE OVER TO DISCHARGE FUEL CHECK SETTINGS RE ADJUST LINKS WITH SERVO IN NEUTRAL SEE MANUAL REPLACE PISTON LINER
ENGINE STALLS	FUEL TANK EMPTY CLOGGED AIR FILTER INCORRECT CARBURETTOR ADJUSTMENT ENGINE OVER HEATING	FILL FUEL TANK CLEAN OR REPLACE AIR FILTER RE ADJUST CARBURETTOR SETTINGS ALLOW ENGINE TO COOL DOWN AND OPEN HIGH SPEED MIXTURE SCREW 90°
POOR ENGINE RESPONSE	INCORRECT CARBURETTOR ADJUSTMENTS FUEL TANK PRESSURE PIPE LOOSE, DETACHED OR DAMAGED OR BLOCKED WORN ENGINE - PISTON LINER	RE ADJUST CARBURETTOR SETTINGS REPLACE OR REFIT PRESSURE PIPE REPLACE PISTON LINER
POOR CAR CONTROL	WEAK BATTERIES IN TRANSMITTER WEAK RECEIVER BATTERIES TRANSMITTER AERIAL NOT FULLY EXTENDED POOR ADJUSTMENT OF LINKS	RECHARGE OR REPLACE BATTERIES RECHARGE OR REPLACE BATTERIES EXTEND AERIAL RE-ADJUST LINK TO INSTRUCTIONS

IMPORTANT - REGULAR MAINTENANCE

Check differential adjustment, check all screws are tight, check gear mesh Adjustment. Oil bearings and keep car clean.



- TRANSMISSION**
- (A)  1.5mm x 7.8mm Pin x 1
 - (B)  5 x 10 x 4mm Bearing x 2
 - (C)  4 x 8 x 3mm Bearing x 2
 - (D)  12 x 18 x 4mm Bearing x 2
 - (E)  M3 x 30 Pan TORX Head x 4
 - (F)  1.5mm x 9.8mm Pin x 1

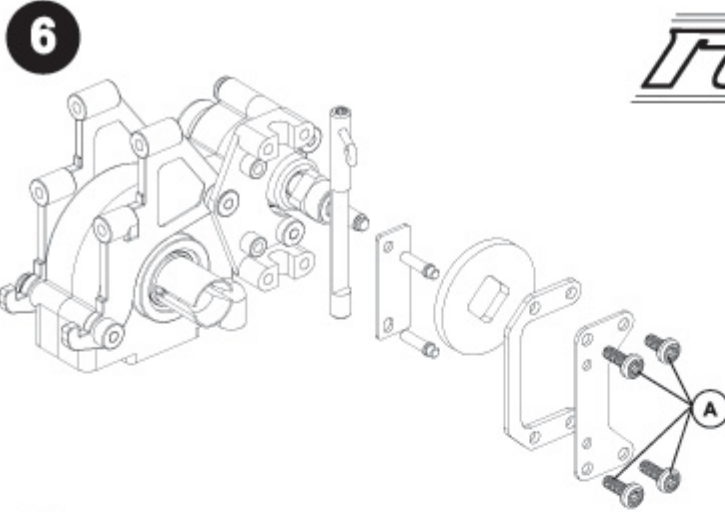

TRANSMISSION
Continued

(A)  **M3 x 8 Pan TORX Head x 4**

(B)  **2mm x 7.8mm Pin x 1**

(C)  **"E" Clip x 1**

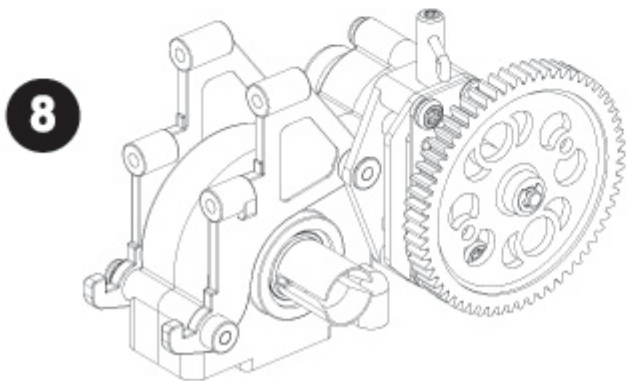
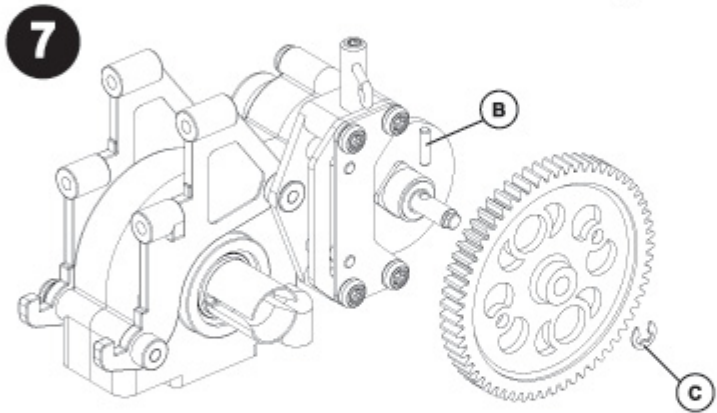

COMPLETE TRANSMISSION

1

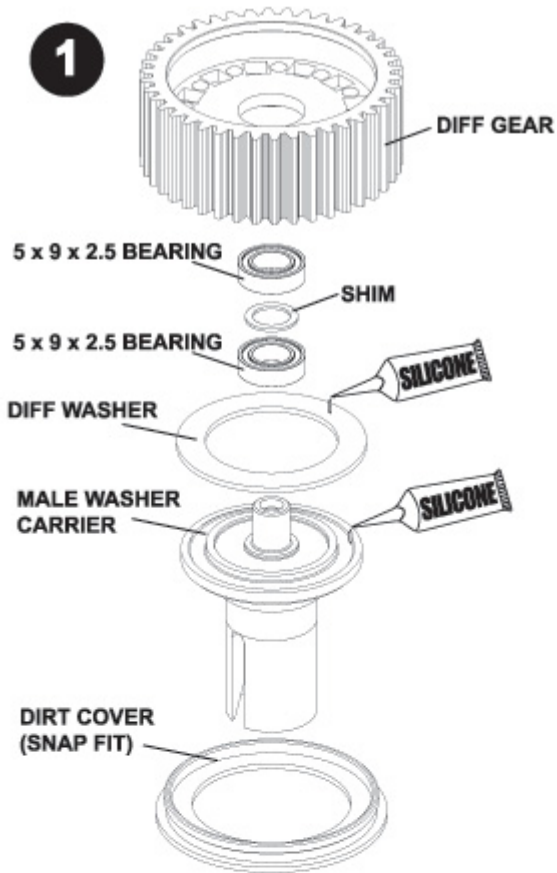

2

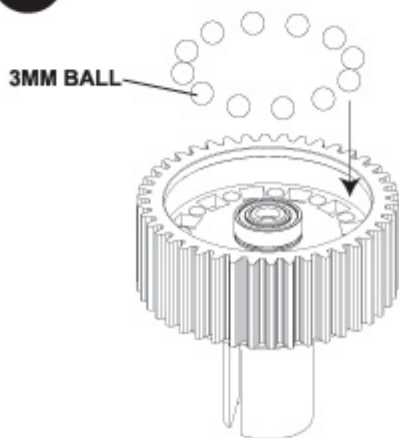

DIFFERENTIAL SERVICE

NOTE:
ONLY USE SCHUMACHER
SILICONE GREASE
PART # U1301



3

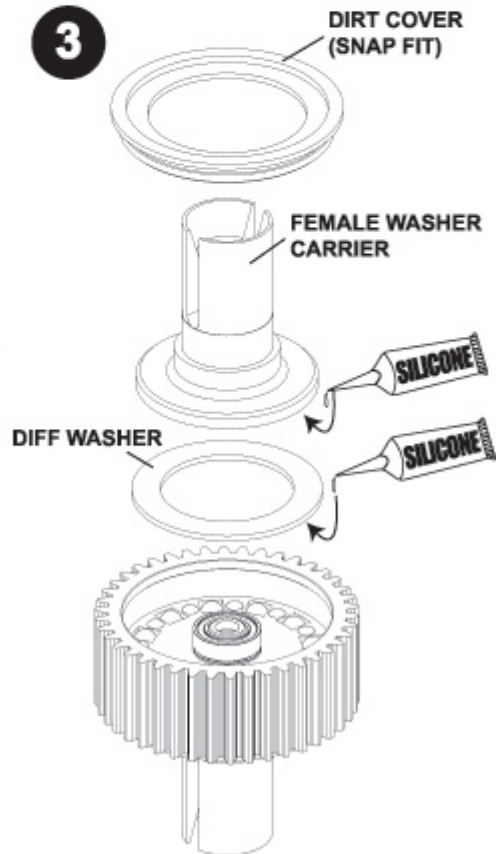

4

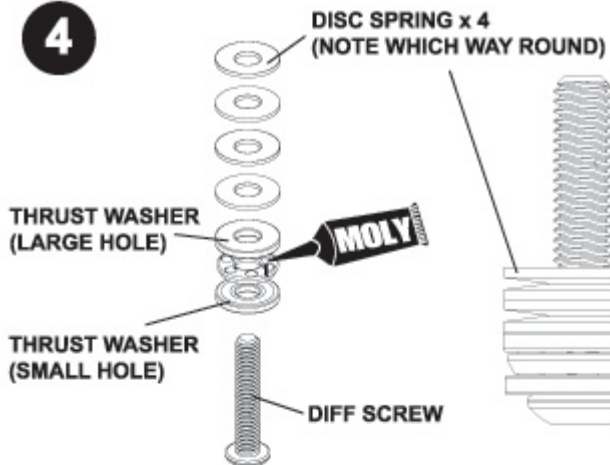

**DIFFERENTIAL
SERVICE
Continued**

**NOTE:
ONLY USE SCHUMACHER
MOLY AXLE GREASE
PART # U1957**



5

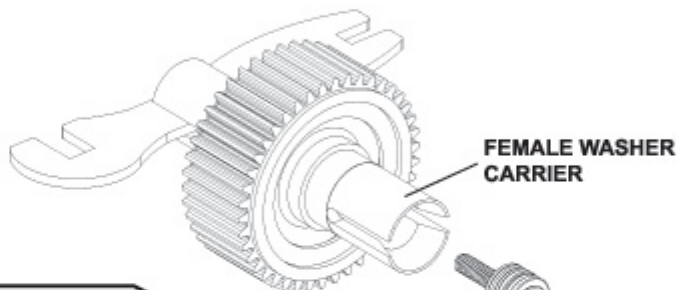

6



**DIFF ADJUSTMENT:
TIGHTEN ALLEN KEY UNTIL
THE DISC SPRINGS ARE FLAT.
THEN UNDO 90 DEGREES.
THEN LOCK WITH THE GRUB SCREW.**

7

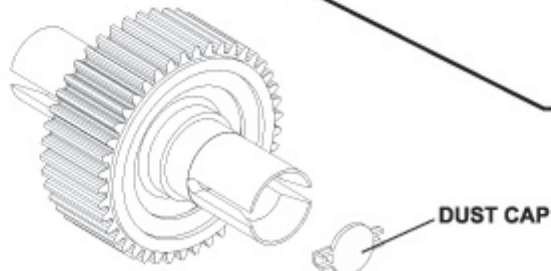

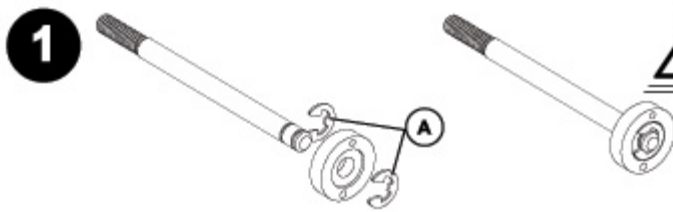

**SHOCK
ABSORBERS**

A 
"E" Clip x 8

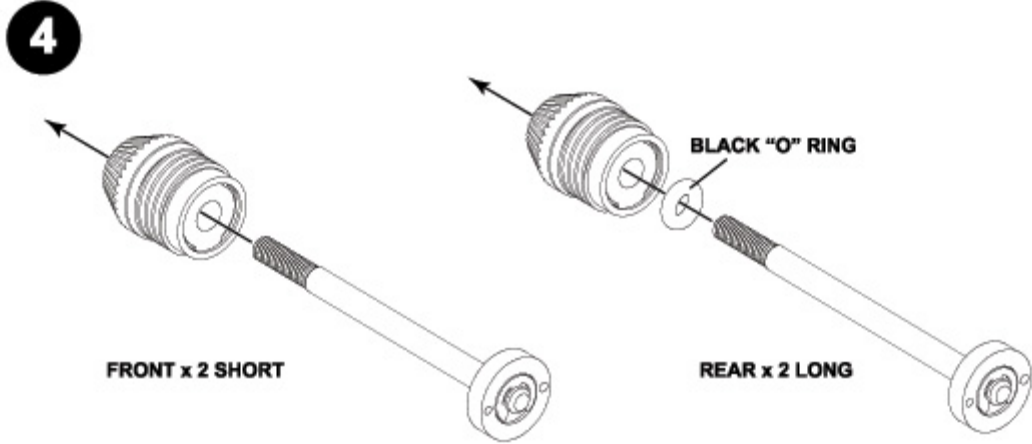
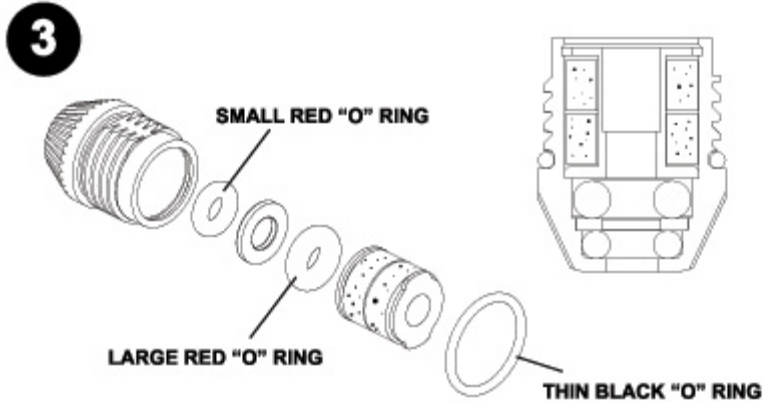

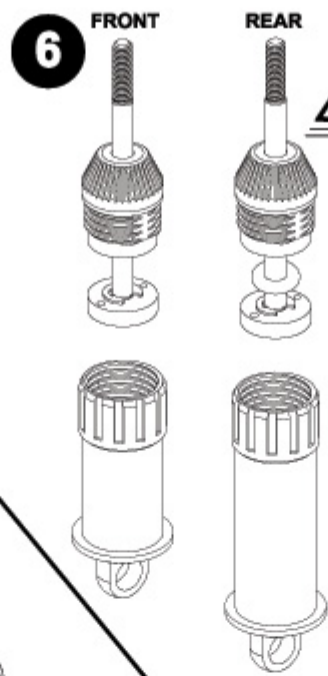

**SHOCK
ABSORBERS
Continued**

A 

2mm Plastic Spacer x 2

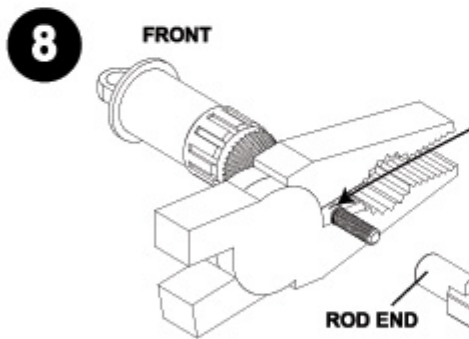
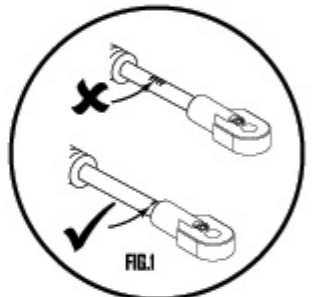
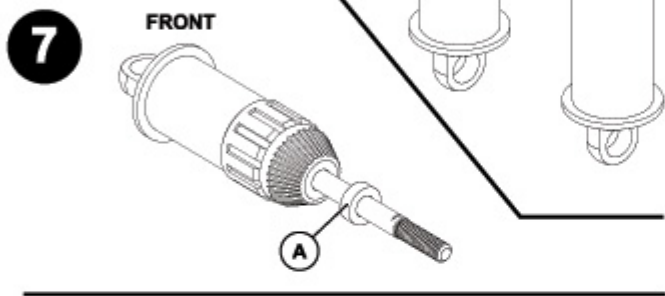

GRIP THE PISTON ROD TO FORM A DENT
BE CAREFUL NOT TO DAMAGE THE POLISHED
SHOCK ROD BEYOND 2MM FROM THE THREAD (SEE FIG.1).

SCREW ROD END ON TO SHAFT
UNTIL NO THREAD IS SHOWING,
BUT NO MORE.

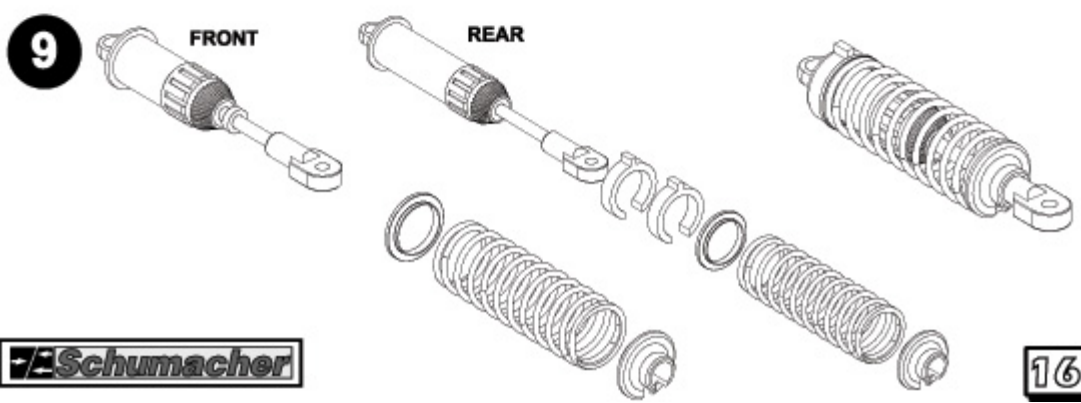

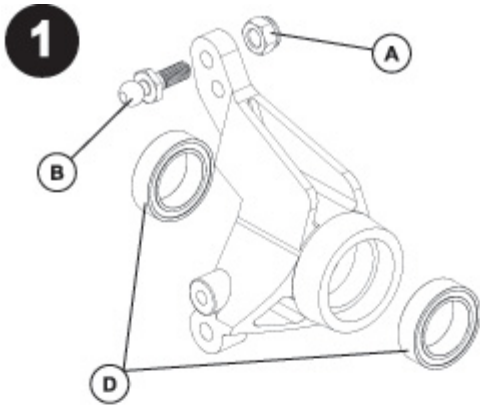

REAR SUSPENSION



M3 Nyloc Nut



Ball Stud Long M3



"E" Clip



10 x 15 x 4mm Bearing



M4 x 25mm Hex Bolt



Tiny "E" Clip

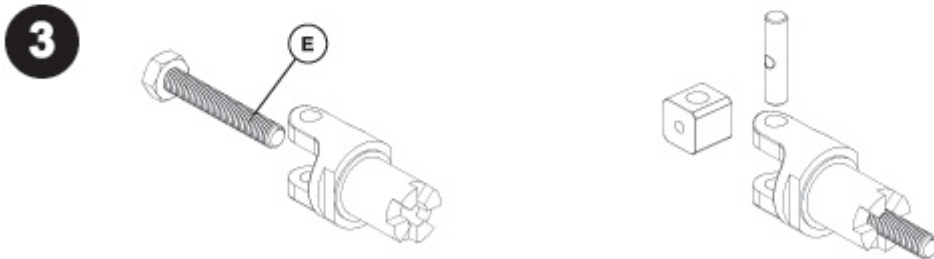
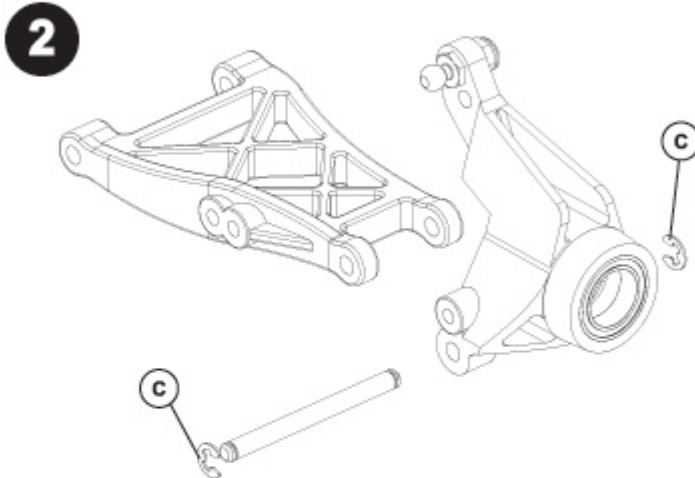

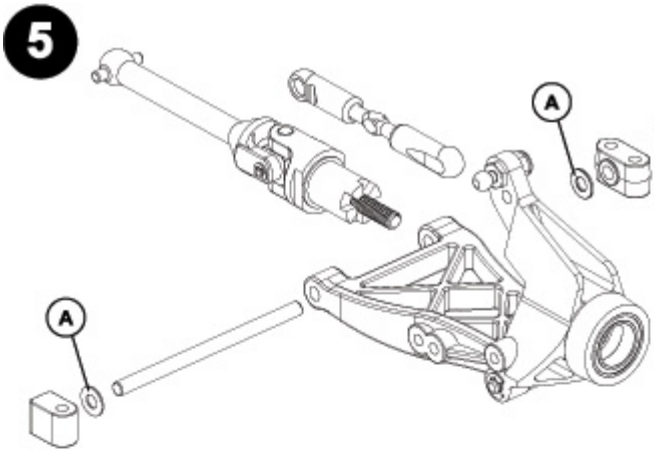

**REAR
SUSPENSION
Continued**

A 
M3 Washer

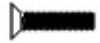
B 
M3 x 12 Csk TORX

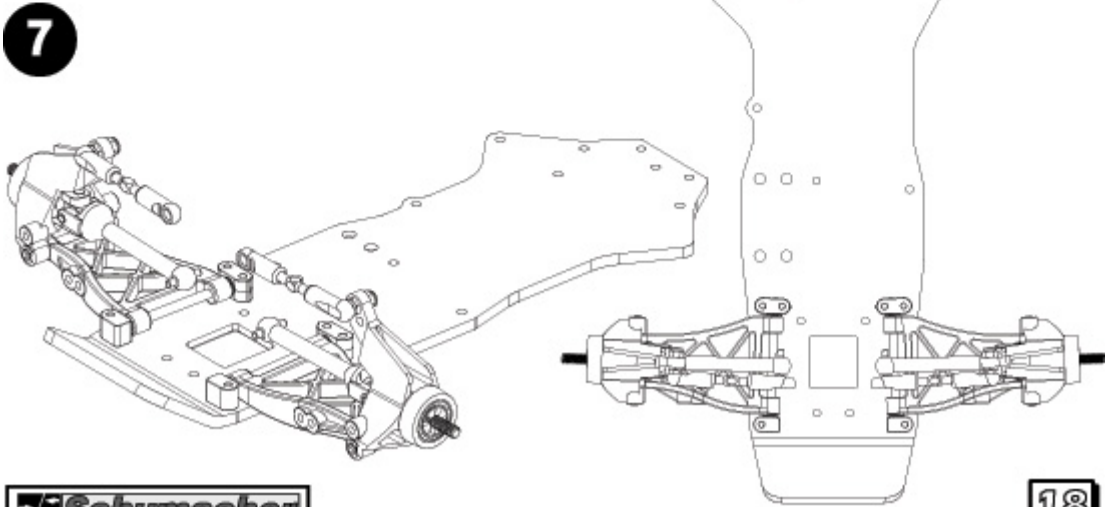
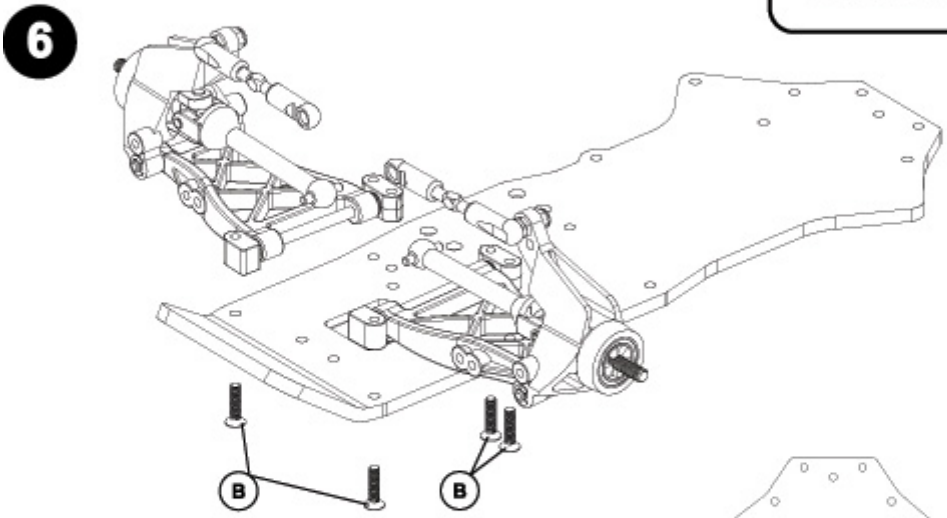

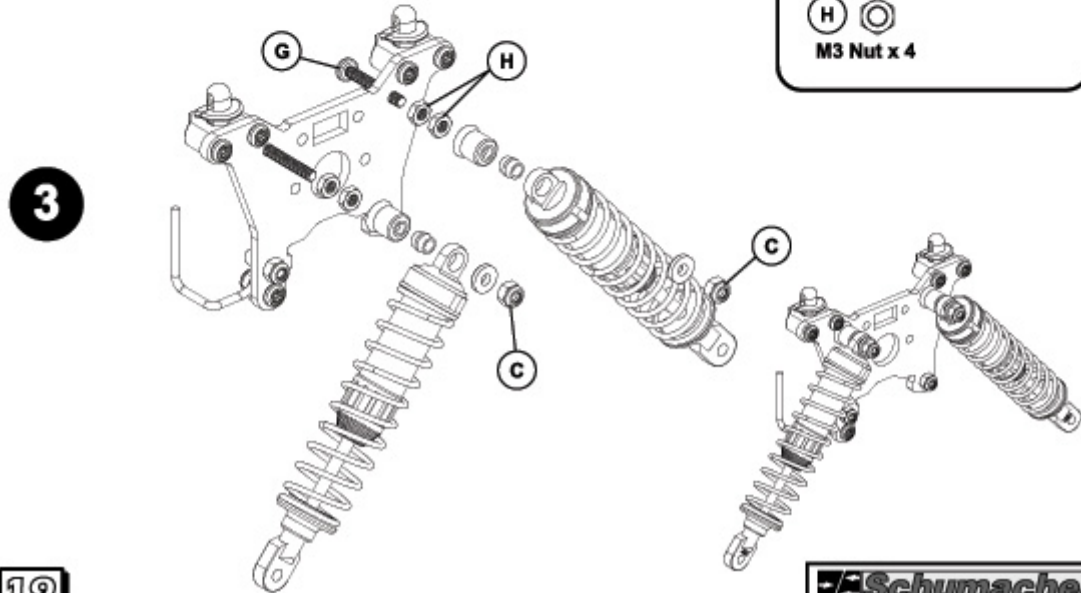
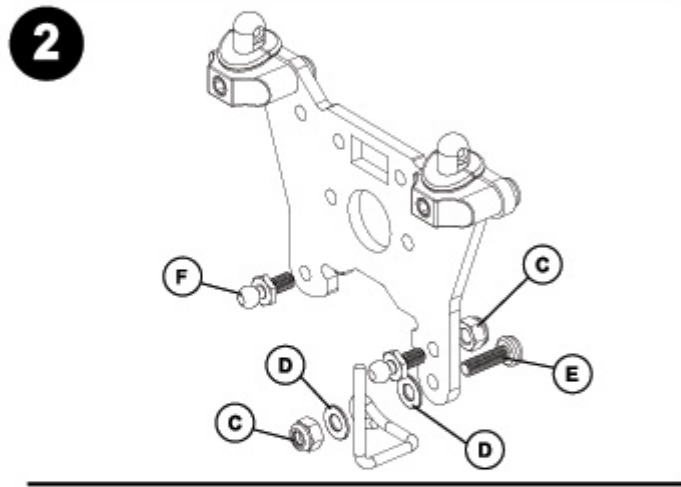
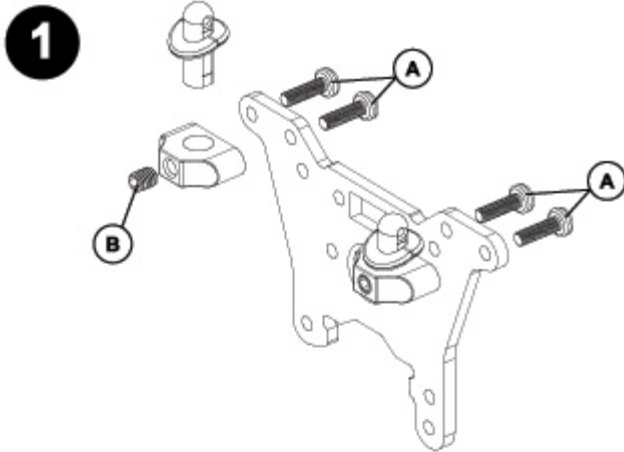

REAR END

A  **M3 x 8 Pan Hd TORX x 4**

B  **M4 x 6 Grub x 2**

C  **M3 Nyloc Nut x 5**

D  **M3 Washer x 2**

E  **M3 x 10 Pan Hd TORX x 1**

F  **Ball Stud Short x 2**

G  **M3 x 20 Pan Hd TORX x 2**

H  **M3 Nut x 4**

4

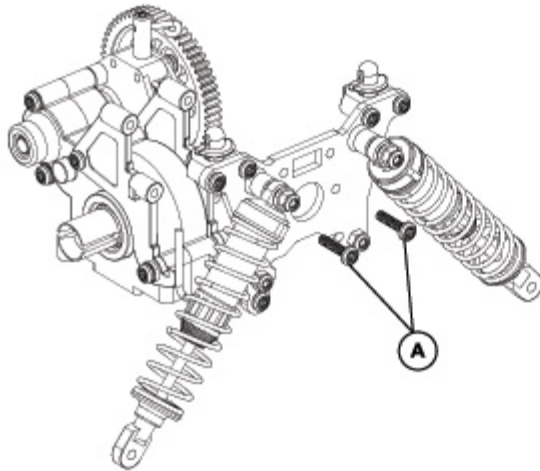

**REAR END
Continued**



M3 x 12 Pan Hd TORX x 2



M3 x 10 Csk Hd TORX x 2



M3 x 10 Pan Hd TORX x 2

5

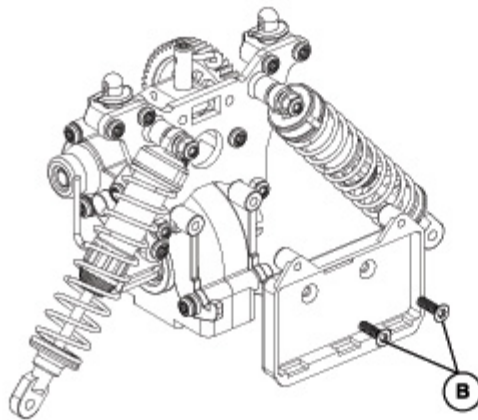

6

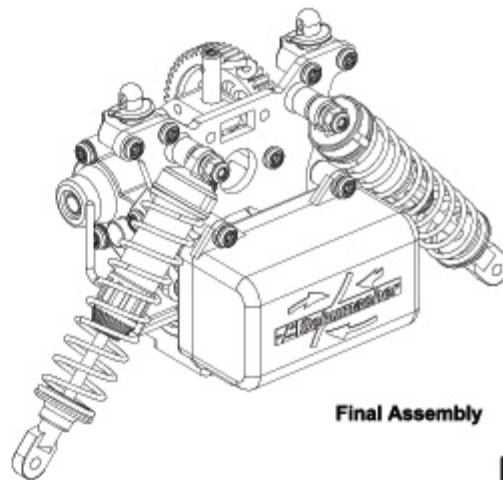
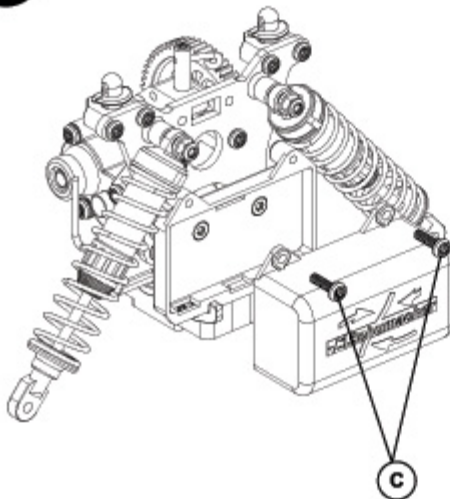

Final Assembly

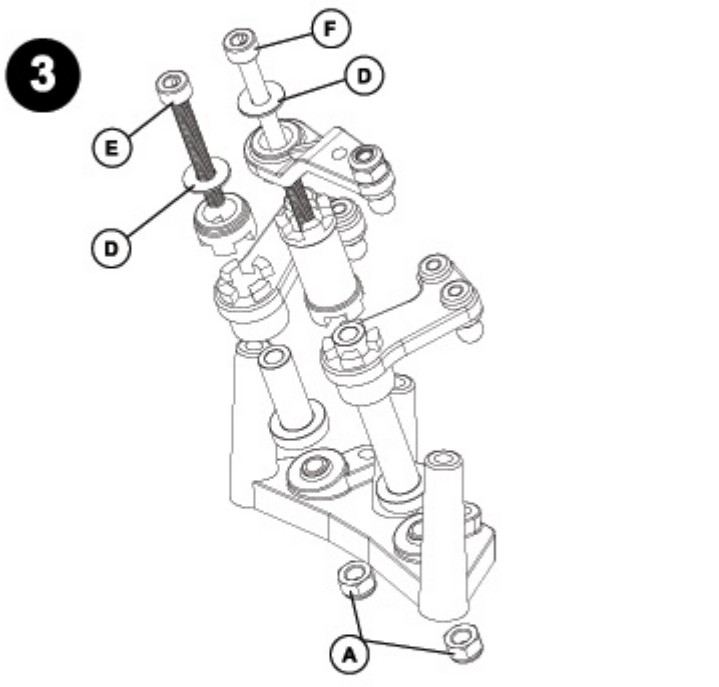
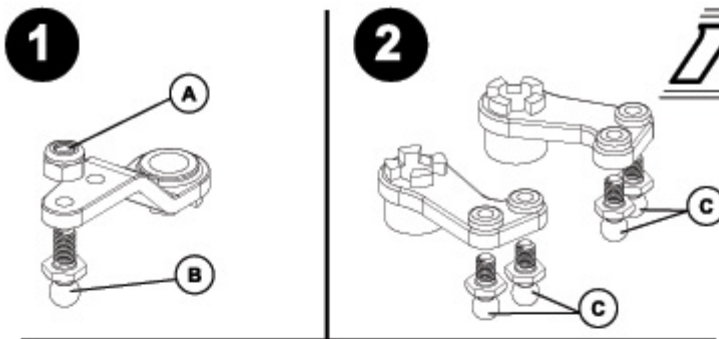

STEERING

- (A)** **M3 Nyloc Nut x 3**
- (B)** **Ball Stud Short x 1**
- (C)** **Ball Stud Ultra Short M3 x 4**
- (D)** **M3 Thrust Washer x 2**
- (E)** **M3 x 25 Cap Hd x 1**
- (F)** **M3 x 45 Cap Hd x 1**

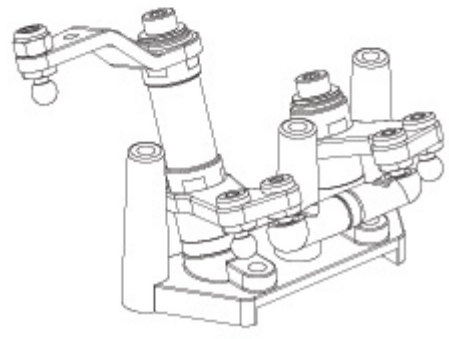
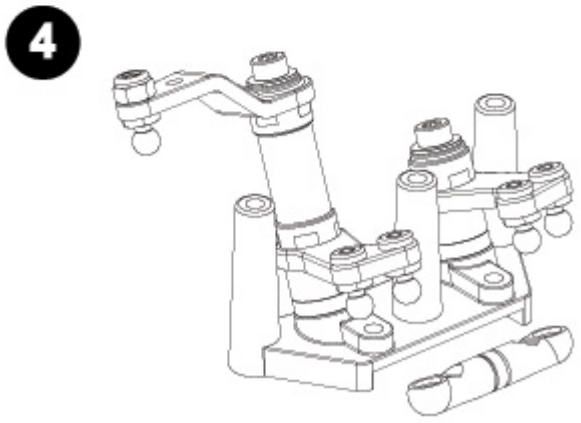

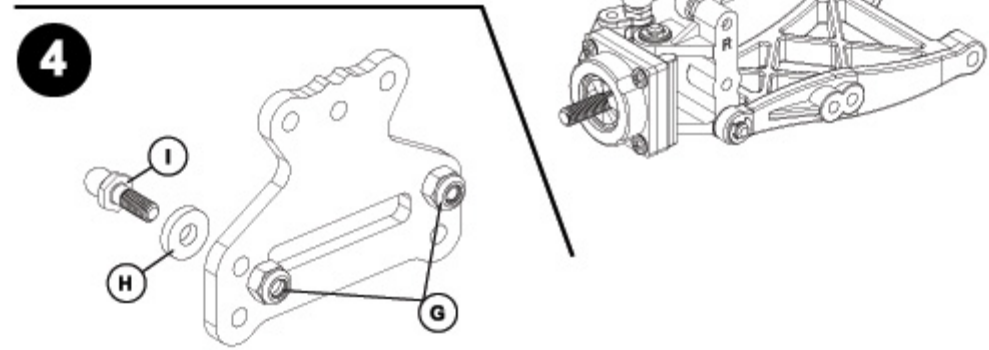
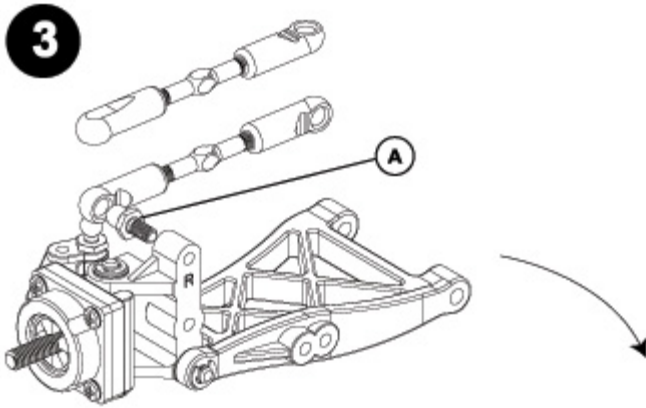
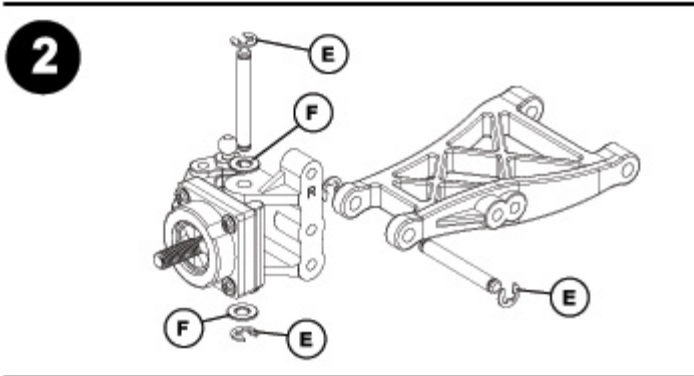
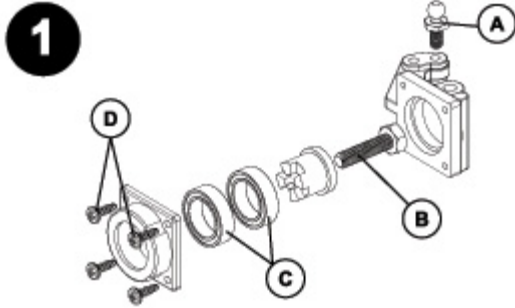

FRONT END

A  **Ball Stud Short x 4**

B  **M4 x 16 Hex Bolt x 2**

C  **10 x 15 x 4mm Bearing x 4**

D  **No 2 x 3/8" Pan x 8**

E  **"E" Clip x 8**

F  **M3 Washer x 4**

G  **M3 Nyloc Nut x 2**

H  **1.6mm Spacer x 2**

I  **Ball Stud Long x 2**

6

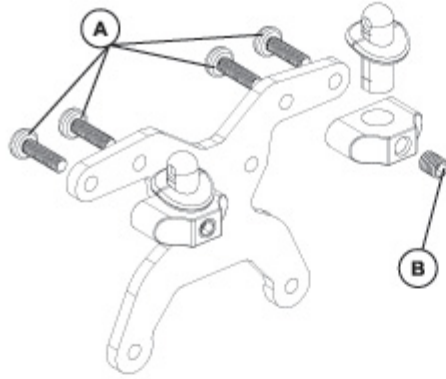

**FRONT END
Continued**

- (A)**  M3 x 8 Pan TORX x 4
- (B)**  M4 x 6 Grub x 2
- (C)**  M3 Nyloc Nut x 4
- (D)**  M3 Steel Washer x 6
- (E)**  M3 x 16 Pan TORX Head x 4
- (F)**  "E" Clip x 4
- (G)**  M3 x 10 Pan TORX Head x 2

7

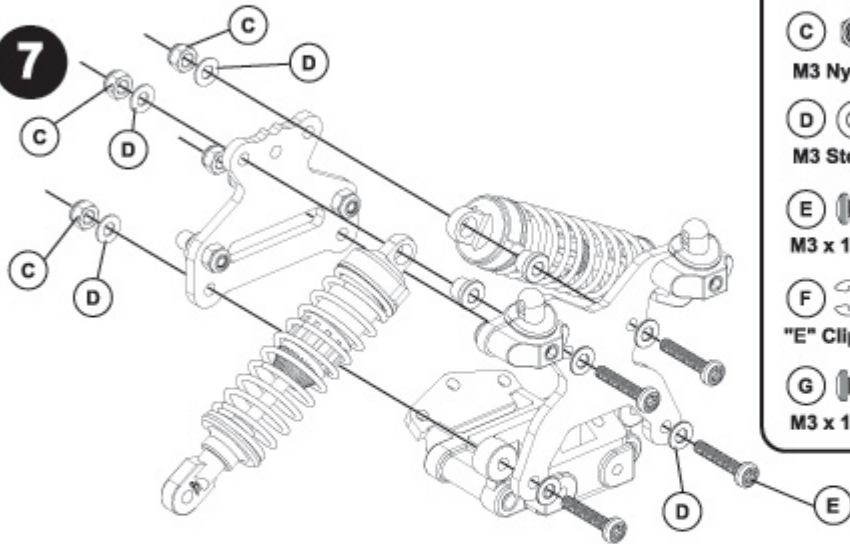

8

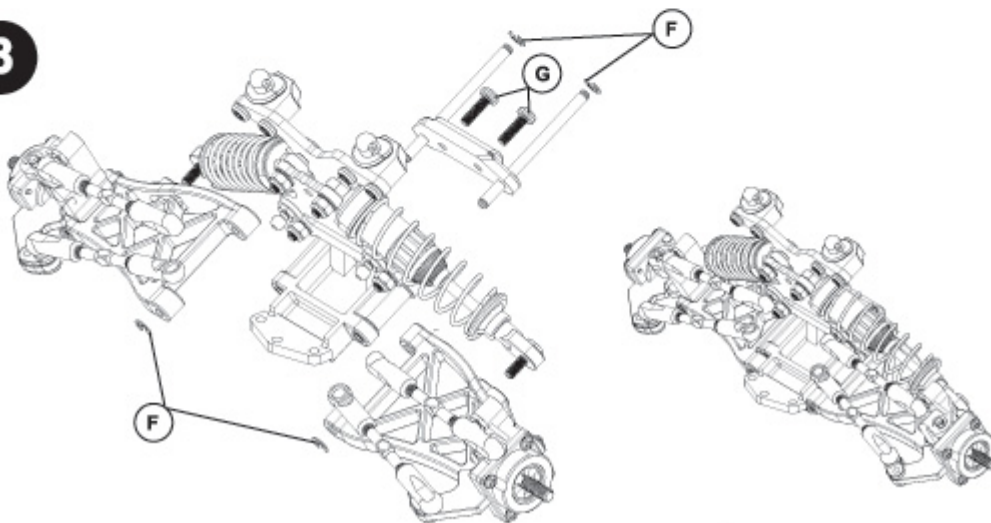

1

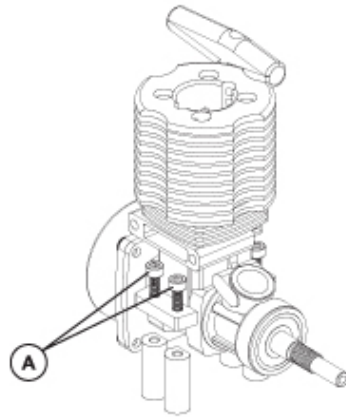

POWER UNIT

A 
M3 x 12 Cap Hd x 4

B 
M3 x 25 Cap Hd x 2

C 
2mm Violet Washer x 2

D 
M3 x 3 Grub Screw x 2

2

APPLY HIGH TEMP
GASKET SEALANT

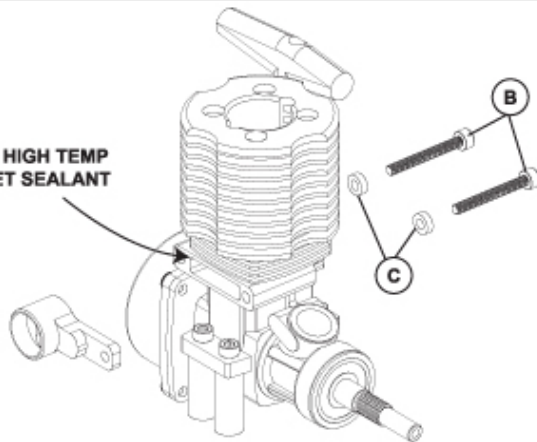

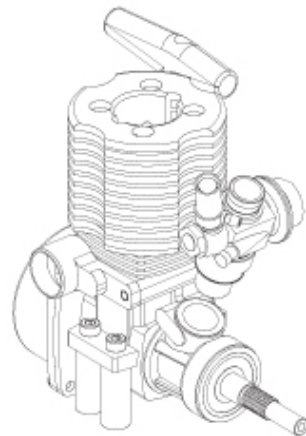
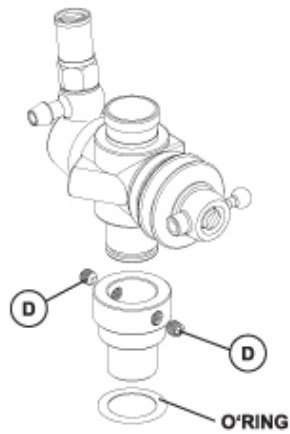

3

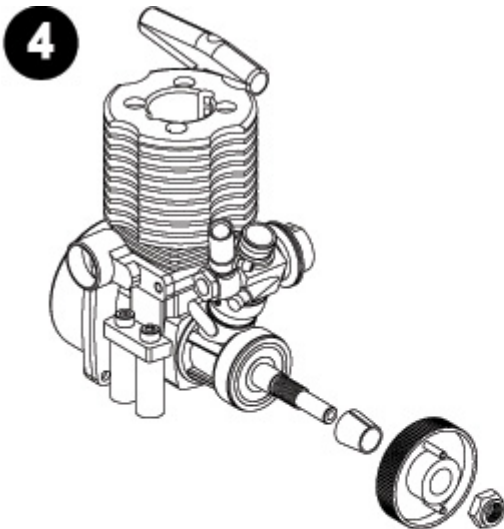



**POWER UNIT
Continued**

- (A)  5mm -Thin Shim x 1
- (B)  1.5mm x 11.8mm Pin x 13
- (C)  M3 x 8 Cap Head x 1

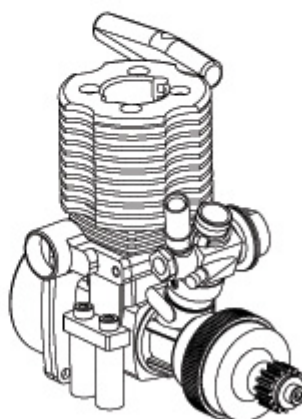
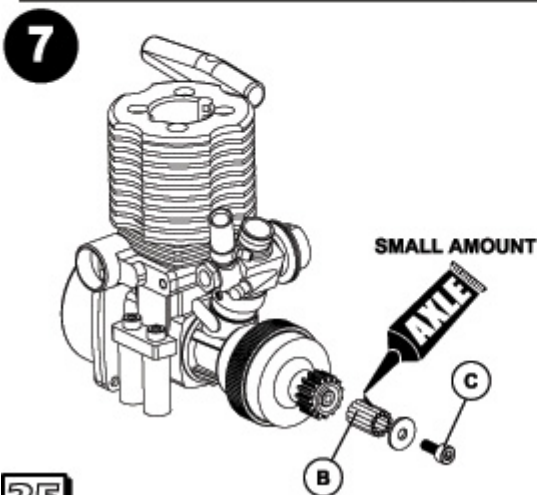
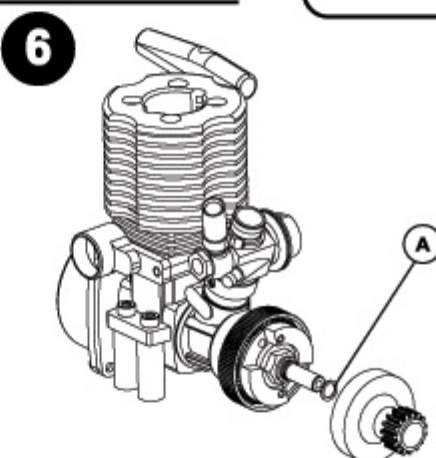
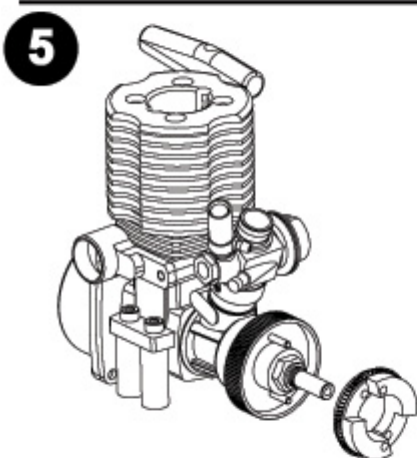



**COMPLETE R18 P/S ENGINE
G69100**

**SCHUMACHER
R18 ENGINE
BREAKDOWN**

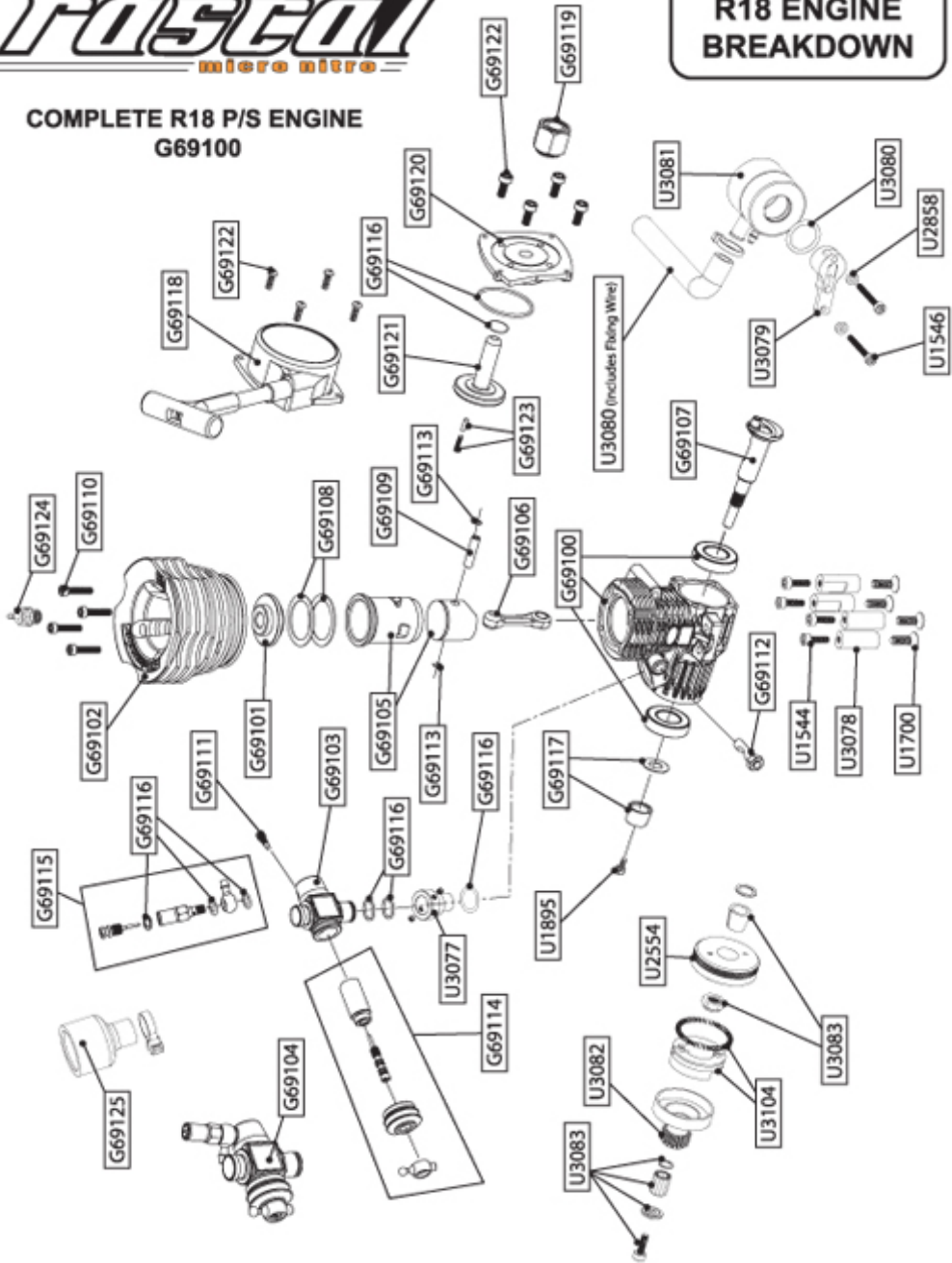

CS Tyre Glue (Cyno)
C4450 (20g)



SPEED SECRETS



Purple Alloy Air Filter
U3045
Dual Stage Foam

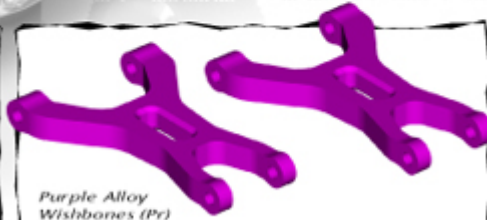

Purple Alloy
Wishbones (Pr)
U3093



Purple Alloy Hinge
Pin Blocks
U3096



Purple Alloy Yokes
U3091



Purple Alloy Rear
Hub Carriers (Pr)
U3092



Purple Alloy Front Hubs
U3090



Purple Alloy Body
Mount Blocks and
Posts (Pr)
U2165



Purple Alloy Shock
Seal Housings (Pr)
U1818



Purple Alloy Shock
Bodies (Pr)
U2660 - Rear
U3095 - Front



Rear Shock Spring Set
(5 Pairs)
U1353

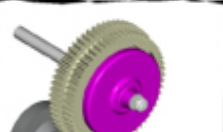

Two Speed Gear Set
U3094



Purple Titanium
Turnbuckles (39mm)
U1572



Front Shock Spring Set
(5 Pairs)
U1352



Purple Titanium
Turnbuckles (35mm)
U1905

Blue – A general purpose, hard wearing compound.
Green – Slightly softer than Blue, but works right through from wet to dry.
Yellow – Softer. Use on very dry days and indoor (Carpet and Polished wood).
B30 – High Grip Tarmac Tyre.



SAFETY

This product is not suitable for children under 14 years of age unless supervised by an adult.



Select an area for assembly that is away from the reach of small children. The parts are small and can be swallowed by children causing choking and possible internal injuries.

Shock fluids, grease and Adhesives should be kept out of childrens reach. They may be toxic and were not intended for human consumption.

Exercise care when using hand tools, sharp instruments or power tools during assembly.

Read the instructions fully and read all manufacturers warnings and cautions for any additional items that may be used for assembly purposes.

Nitro Fuel is extremely hazardous READ all the manufacturers Warnings before opening the Container.

ALWAYS drive your car safely, away from public roads, and be aware of any people or animals near you. MODEL CARS CAN BE DANGEROUS!

WARNINGS

Use good quality fuel with synthetic oil such as Model Technics Dynaglow, Jets, Magnum, O'Donnel or Blue Thunder, with 16% -25% nitro content. We do not recommend castor oil based fuels, as it leaves a "sticky residue" which can cause the Pull start one way bearing to slip. A higher nitro content fuel will give more power, but will make the engine run hotter.

Nitro fuel, particularly racing fuels with a high nitro content and low oil content, is very corrosive, and can cause the engine to rust if fuel is left inside it. We recommend running the car completely out of fuel, if it is to be left unused for a few days. This can be done by allowing the fuel tank to empty or by squeezing the fuel line until the engine stops. After run oil such as Ultimate Racing UR0903 also helps to reduce corrosion. Remove the glo plug or air filter, and put a few drops of after run oil into the engine. Then turn the engine over a few times with the pull start or e-start to circulate the oil around the moving parts. We cannot warranty a rusty engine.

NEVER run the engine without the air filter fitted and never pull the Pull Start cord to full length use short strokes only.

Don't run the car at full throttle with the wheels off the ground, the engine MAY blow up in a matter of seconds.

Learn to use your power with respect. Very few surfaces can cope with full power. If you use full power everywhere you WILL break things!

Always ensure the transmitter & receiver batteries are fully charged before use.

Always ensure that all nuts and screws are tight and that the gear mesh is correct.

Run in a new engine by using a rich fuel mixture, to ensure plenty of lubrication, and use no more than half throttle for the first 2 or 3 tanks of fuel.

Superglue the tyres to the wheels as they may come off at high speeds. Running tyres with a larger diameter of those supplied with the kit will over-gear the car. This will cause excessive loads and thus un-due wear and tear.

This product is not a toy. It is a hobby product capable of high performance, but will require regular maintenance. Learn to drive the car slowly at first, away from solid objects. The Riot is capable of Small jumps and stunts, but heavy impact can cause damage.



www.racing-cars.com



NITRO - OFF ROAD CARS

K095	Rascal 2 - Nitro Truck; ARR - Blue
K096	Rascal 2 - Nitro Truck; ARR - Red
K097	Rascal 2 - Nitro Truck; ARR - Silver
K098	Rascal 2 - Nitro Truck; Blue - RTR
K099	Rascal 2 - Nitro Truck; Red - RTR
K100	Rascal 2 - Nitro Truck; Silver - RTR

CHASSIS PARTS

U119	Aerial Tube - Pack 4
U2079	Mini Front Bumper
U2154	Lite Body Post Set; 2 vert 2 horiz
U3046	CNC Alloy Chassis - Rascal
U3047	Body Mount; front - Rascal
U3048	Chassis Post - Rascal (pr)
U3049	Battery Box - Rascal
U3050	Front Suspension Mount - Rascal
U3051	Moulding Set - Rascal
U3052	Radio Box - Rascal
U3053	Top Deck & Radio Tray - Rascal
U3061	Shock Mount; rear - Rascal
U3062	Shock Mount; front - Rascal
U3063	Steering Link - Rascal
U3101	Grommet - 25mm (pk3)
U3105	Instr Manual - RASCAL

BODYSHELLS & DECALS

U5086	Body & Decal; Clear - Rascal
U5087	Body & Decal; Blue - Rascal
U5088	Body & Decal; Red - Rascal
U5089	Body & Decal; Silver - Rascal

SUSPENSION

U1425	Pivot Pin; Grooved 1-8 x 44mm
U1430	Turnbuckle Adjuster - 39mm (pr)
U1452	Front Bulkhead - 2WD
U1704	Ball Grippa Sockets (pk 8)
U2450	Suspension Pivots & Blocks - Mission
U2662	Pivot Pin; plain 53mm x 1/8
U2722	Ball Grippa Joints - U/Sh Stud 4prs
U3054	Bush; shock mount - Rascal (pr)
U3055	Centre Track Rod - Rascal
U3056	Front Hub Carrier & Axle - Rascal (pr)
U3057	Hub Carrier; Rear - Rascal (pr)
U3058	Pivot Pin; grooved 35mm x 1/8 - Rascal (pr)
U3059	Rose Joint Screw - Rascal (pk 4)
U3060	Rose Joint Socket - Rascal (pk 4)
U3061	Shock Mount; rear - Rascal
U3062	Shock Mount; front - Rascal
U3063	Steering Link - Rascal
U3064	Steering Moulding Set - Rascal
U3065	Steering Posts - Rascal
U3066	Wishbone; front or rear - Rascal
U3067	Yoke C Hub - Rascal (pr)
U3103	Pivot Pin; grooved 23mm x 1/8 (pr)
U750	Ball Grippa Joints-Short Stud 8prs
U797	Turnbuckle Adjuster - 35mm (pr)
U851	Ball Grippa Joints - Long Stud 8prs

SHOCK ABSORBERS

U1233	Piston Rod - Med Shock (pr)
U1258	Piston Rod - Short Shock (pr)
U1272	Vari Shock Body - Short (pr)
U1274	Vari Shock Body - Long (pr)
U1310	Shock Mouldings-Vari Click Piston (pr)
U1818	Purple Alloy Shock Seal Housing (pr)
U2143	One Piece Shock Pistons - 4 sets of 3
U2660	Alloy Shock Body; Long Purple (pr)
U3095	Alloy Shock Body; Short Purple (pr)
U3099	Alloy Front Shocks; assembled - Rascal (pr)
U3100	Alloy Rear Shocks; assembled - Rascal (pr)
U613	Spring Stop & Spacer Mouldings (pr)
U835	Vari Shock Seal Pack (pr)

SPRINGS

U1352	Spring Tuning Set; Medium (5prs)
U1353	Spring Tuning Set; Long (4prs)
U1382	Yellow Shock Springs-Long; rate 2 (pr)
U1385	Yellow Shock Springs - Med; rate 2 (pr)

TRANSMISSION

U1635	Disc Brake Cam - Nitro 10/2000
U1636	Disc Brake Repair Set - Nitro
U1832	Idler Gear Shaft - RASCAL
U1895	M3x8mm Button Screws & Washers pk4
U2174	61T - 32DP
U2333	Universal Joints Bag (pr)
U3068	Diff Half; female - Rascal
U3069	Diff Half; male - Rascal
U3070	Driveshafts & Axles - Rascal (pr)
U3071	Gear Set - Rascal
U3072	Layshaft - Rascal
U3073	Transmission Housings - Rascal
U3088	Diff; Complete & Assembled - Rascal
U3089	Diff Rebuild Kit - Rascal
U3109	Layshaft - 2/3 Speed
U3110	Spur Gears 57 & 61T - 2 Speed
U3111	Pawl Assy & Alloy Cover - 2 Speed
U3112	Pinion Bell - 15+19 2 Speed
U730	Thrust Bearing

BEARINGS & BALLS

G200	ZX1 - Microlube
U1954	Pro - Thrust Bearing
U2574	Ball Bearing - 5 x 9 x 2.5 (pr)
U2698	Ball Bearing - 5 x 10 x 4 Sealed (pr)
U2699	Ball Bearing - 10 x 15 x 4 Sealed (pr)
U3074	Ball Bearing 12x18x4mm 2RS (pr)
U3075	Ball Bearing 4x8x3mm 2RS - Rascal (pr)

1-10 OFF-ROAD TYRES

T692	Block - Rear Tyres - Blue - CAT (pr)
U6516	Mini Spike - Rear Tyres - Green - 2.2 (pr)
U6518	Mini Spike - Rear Tyres - Blue - 2.2 (pr)
U6558	Mini Spike - Rear Tyres - Yellow - 2.2 (pr)
U6602	Mini Pin - Blue - Rear - 2.2 (pr)
U6608	Mini Pin - Yellow - Rear - 2.2 (pr)
U6744	Mini Mag Block; PreGlue - SOFT - Rascal 2 pr
U6745	Mini Mag Block; PreGlue - HARD - Rascal 2 pr

2.2' ON-ROAD TYRES

U6573	Road & Track - RT2 Rear - Green (pr)
U6614	Road & Track - RT1 - Rear - Green (pr)
U6710	Road & Track - RT1 - Rear - B30 (pr)
U6720	VENOM 88 Road Tyre - Rascal (pr)

1-10 OFF-ROAD WHEELS & INSERTS

U3086	Wheel; White 5 Spoke - Rascal (pr)
U3087	Wheel; Chrome 5 Spoke - Rascal (pr)
U3097	Wheel; White 10 Spoke - Rascal (pr)
U3098	Wheel; Chrome 10 Spoke - Rascal (pr)
U6668	Foam Tyre Inserts; Soft - Ultra Wide (pr)
U6669	Foam Tyre Inserts; Hard - Ultra Wide (pr)
U6734	Foam Tyre insert; Med - Rear - CAT (pr)

SHOCK OIL

G020 Pure Silicone Shock Oil - 20w
G025 Pure Silicone Shock Oil - 25w
G030 Pure Silicone Shock Oil - 30w
G035 Pure Silicone Shock Oil - 35w
G040 Pure Silicone Shock Oil - 40w
G045 Pure Silicone Shock Oil - 45w
G050 Pure Silicone Shock Oil - 50w
G055 Pure Silicone Shock Oil - 55w
G060 Pure Silicone Shock Oil - 60w
G070 Pure Silicone Shock Oil - 70w

SPEED PACKS

CR035 CORE RC - Serrated Alloy M4 Nuts; Blue pk 4
CR036 CORE RC - Serrated Alloy M4 Nuts; Purple pk 4
H1010 Body Clips - Fluorescent Yellow (pk10)
H1011 Body Clips - Fluorescent Green (pk10)
H1012 Body Clips - Fluorescent Red (pk10)
H1013 Body Clips - Metallic Red (pk10)
H1014 Body Clips - Metallic Blue (pk10)
H1015 Body Clips - Metallic Purple (pk10)
U1540 SPEED PACK - Short M3 Pan Hd
U1544 SPEED PACK - Short M3; Cap Hd
U1546 SPEED PACK - M3 Cap Hd 25;30;35;45mm
U1547 SPEED PACK - M3 Nuts
U1548 SPEED PACK - M3 Washers
U1549 SPEED PACK - M4 Nuts & Washers
U1551 SPEED PACK - E Clips 2x8pcs
U1552 SPEED PACK - R Clips
U1565 SPEED PACK - Small Self Tap; PanHd
U1633 SPEED PACK - Small Pins (pk)
U1700 SPEED PACK-M4x12 Csk Hi Tensile (4)
U1771 SPEED PACK - Tywraps (pk25)
U1960 SPEED PACK - O Rings; Various
U1962 SPEED PACK - O Rings3.3x2.4ID - pk6
U2128 SPEED PACK - Grub-Set Screws M3 M4
U2344 SPEED PACK-M4 16;20;25;30 Bolts (pk8)
U2590 SPEED PACK - Torx M3 x 10 Csk
U2591 SPEED PACK - Torx M3 x 12 Csk
U2631 SPEED PACK - Circlips Various 12 pcs
U2640 SPEED PACK - Torx M3x6mm Pan Hd
U2641 SPEED PACK - Torx M3x8mm Pan Hd
U2642 SPEED PACK - Torx M3x10mm Pan Hd
U2643 SPEED PACK - Torx M3x12mm Pan Hd
U2644 SPEED PACK - Torx M3x16mm Pan Hd
U2645 SPEED PACK - Torx M3x20mm Pan Hd
U2760 SPEED PACK - M3 Button Hd; 4 to 20
U2940 SPEED PACK - Torx M3x30 Pan Hd

NITRO ACCESSORIES

CR046 CORE RC - Long Glow Starter; Purple Alloy + Meter
CR047 CORE RC - Long Glow Starter; Blue Alloy + Meter
G852 Nitro Starter Set - UK 240v
G853 Glow Starter; 1800NiMH - UK 240v
G857 Roto Electric Starter X18 X28 R18
G858 Roto Start Assy - Sch X18 R18
G859 Nitro Starter Bag - requires D Cell
G860 Roto Starter Shaft - Sch X18 X28 R18
U2554 Flywheel - 18/21
U2851 Fuel Filter; Purple Alloy+Sintered Filter
U3045 Air Filter; Purple Alloy - 12 to 18 engines
U3076 Battery Holder; 4xAAA
U3077 Carb Extension - Rascal
U3078 Engine Mount Post - Rascal (pk 4)
U3079 Manifold - Rascal
U3080 Mounting Set; muffler - Rascal
U3081 Muffler - Rascal
U3082 Pinion Clutch Bell; 15T - Rascal
U3083 Pinion Service Kit - Rascal/Riot
U3084 Radio Switch & Wiring - Rascal
U3085 Thottle & Brake Link Set - Rascal
U3102 Fuel Tank - Rascal
U3104 Clutch Shoes & Spring - 18
U3108 Pinion Bell Service Kit; Needle Bearing

BATTERIES

G718 GP Alkaline AA Pencil; Card 4
G721 AA Pencil 2700NiMH - Card 4
G744 AAA 1000 NiMH - Card 4
G745 AAA Rx Battery NiMH 800 - 6.0v
G746 AAA Alkaline Battery - Card 4



NITRO MOTORS & PARTS

G69100 Schumacher R18 P/S Engine
G69101 Burn Room - Sch R18
G69102 Cylinder Head - Sch R18
G69103 Carb Main Body - Sch R18
G69104 Carb Complete - Sch R18
G69105 Cylinder Sleeve/Piston - Sch R18
G69106 Connecting Rod - Sch R18
G69107 Crankshaft - Sch R18
G69108 Head Shim Washer 1pcs - Sch R18
G69109 Wrist Pin - Sch R18
G69110 Cylinder Head Bolt 4pcs - Sch R18
G69111 Idle Adjust Screw - Sch R18
G69112 Carb Pinch Bolt - Sch R18
G69113 Circlips; Wrist Pin - Sch R18
G69114 Slide Assy; Carb - Sch R18
G69115 Needle Assy; Hi Speed - Sch R18
G69116 O Ring Set; Carb & Back Plate - Sch R18
G69117 Cone & Washer; Crankshaft - Sch R18
G69118 Plastic Parts; Pull Start - Sch R18
G69119 One Way Bearing Set - Sch R18
G69120 Back Plate - Sch R18
G69121 Starting Shaft - Sch R18
G69122 Rear Cover Bolts M2.6x6 - Sch R18
G69123 Pin & Spring; Pull Start - Sch R18
G69124 Glow Plug - Sch R18
G69125 Air Filter - Sch R18

SPEED SECRET - OPTION PARTS

NE412 Alloy Wheel Adaptors; 12mm - Rascal pk4
NE910 Chrome Moly Steel Roll Cage - Rascal
U1572 Titanium Turnbuckle; purple - 39mm (pr)
U1905 Titanium Turnbuckle; purple - 35mm (pr)
U2135 M4 Nyloc Wheel Nut - Purple Alloy (pk4)
U2165 Alloy Blocks & Flex Body Post - Vertical
U2810 M4 Nyloc Wheel Nut - Red Alloy (pk4)
U2811 M4 Nyloc Wheel Nut - Blue Alloy (pk4)
U2812 M4 Nyloc Wheel Nut - Black Alloy (pk4)
U2813 M4 Nyloc Wheel Nut - Gold Alloy (pk4)
U3090 Alloy Front Hub Carrier - Rascal
U3091 Alloy Front Yokes - Rascal
U3092 Alloy Rear Hub Carrier - Rascal
U3093 Alloy Wishbone; Fr or Rr - Rascal
U3094 2 Speed Gearbox - Rascal
U3096 Alloy Pivot Blocks - pk4
U3231 Alloy Front Axle - Rascal & Riot (pr)
U3232 Alloy Rear Axle - Rascal & Riot (pr)

ELECTRONICS

G829 Transmitter 27Mhz Wheel
G830 Transmitter 27Mhz 2 Stick
G831 Receiver 27Mhz
G833 Servo - 3.0 Kg Cm 0.19 sec/60deg
G837 Mini Temp Gun - 420F 230C
G851 Servo; Metal Gears - 9.0 Kg Cm 0.2 sec/60deg
H1033 Micro Failsafe; waterproof
H1042 Nicad Switch + Ext Charge Socket

TOOLS

H1016 Fuel Bottle - 250cc
H1017 Fuel Bottle - 500cc
H1018 5 Way Glow Plug Wrench
H1025 4 Way Glow Plug Wrench
H1030 Nitro Cleaner Aerosol 500ml
H1037 Pipercross Air Filter Oil - Aerosol
H1038 Pipercross Air Filter Cleaner - Aerosol
H1055 GT85 Lube & Clean Aerosol 400ml
U2789 Schumacher Hex Driver - 1.5mm
U2790 Schumacher Hex Driver - 2.0mm
U2791 Schumacher Hex Driver - 2.5mm
U2792 Schumacher Hex Driver - 3.0mm
U2794 Schumacher Driver - T10 TORX
U2795 Schumacher M3 Nut Driver
U2796 Schumacher M4 Nut Driver
U2818 Schumacher Body Reamer

SHOCK OIL

G020 Pure Silicone Shock Oil - 20w
G025 Pure Silicone Shock Oil - 25w
G030 Pure Silicone Shock Oil - 30w
G035 Pure Silicone Shock Oil - 35w
G040 Pure Silicone Shock Oil - 40w
G045 Pure Silicone Shock Oil - 45w
G050 Pure Silicone Shock Oil - 50w
G055 Pure Silicone Shock Oil - 55w
G060 Pure Silicone Shock Oil - 60w
G070 Pure Silicone Shock Oil - 70w

SPEED PACKS

CR035 CORE RC - Serrated Alloy M4 Nuts; Blue pk 4
CR036 CORE RC - Serrated Alloy M4 Nuts; Purple pk 4
H1010 Body Clips - Fluorescent Yellow (pk10)
H1011 Body Clips - Fluorescent Green (pk10)
H1012 Body Clips - Fluorescent Red (pk10)
H1013 Body Clips - Metallic Red (pk10)
H1014 Body Clips - Metallic Blue (pk10)
H1015 Body Clips - Metallic Purple (pk10)
U1540 SPEED PACK - Short M3 Pan Hd
U1544 SPEED PACK - Short M3; Cap Hd
U1546 SPEED PACK - M3 Cap Hd 25;30;35;45mm
U1547 SPEED PACK - M3 Nuts
U1548 SPEED PACK - M3 Washers
U1549 SPEED PACK - M4 Nuts & Washers
U1551 SPEED PACK - E Clips 2x8pcs
U1552 SPEED PACK - R Clips
U1565 SPEED PACK - Small Self Tap; PanHd
U1633 SPEED PACK - Small Pins (pk)
U1700 SPEED PACK-M4x12 Csk Hi Tensile (4)
U1771 SPEED PACK - Tywraps (pk25)
U1960 SPEED PACK - O Rings; Various
U1962 SPEED PACK - O Rings3.3x2.4ID - pk6
U2128 SPEED PACK - Grub-Set Screws M3 M4
U2344 SPEED PACK-M4 16;20;25;30 Bolts (pk8)
U2590 SPEED PACK - Torx M3 x 10 Csk
U2591 SPEED PACK - Torx M3 x 12 Csk
U2631 SPEED PACK - Circlips Various 12 pcs
U2640 SPEED PACK - Torx M3x6mm Pan Hd
U2641 SPEED PACK - Torx M3x8mm Pan Hd
U2642 SPEED PACK - Torx M3x10mm Pan Hd
U2643 SPEED PACK - Torx M3x12mm Pan Hd
U2644 SPEED PACK - Torx M3x16mm Pan Hd
U2645 SPEED PACK - Torx M3x20mm Pan Hd
U2760 SPEED PACK - M3 Button Hd; 4 to 20
U2940 SPEED PACK - Torx M3x30 Pan Hd

NITRO ACCESSORIES

CR046 CORE RC - Long Glow Starter; Purple Alloy + Meter
CR047 CORE RC - Long Glow Starter; Blue Alloy + Meter
G852 Nitro Starter Set - UK 240v
G853 Glow Starter; 1800NiMH - UK 240v
G857 Roto Electric Starter X18 X28 R18
G858 Roto Start Assy - Sch X18 R18
G859 Nitro Starter Bag - requires D Cell
G860 Roto Starter Shaft - Sch X18 X28 R18
U2554 Flywheel - 18/21
U2851 Fuel Filter; Purple Alloy+Sintered Filter
U3045 Air Filter; Purple Alloy - 12 to 18 engines
U3076 Battery Holder; 4xAAA
U3077 Carb Extension - Rascal
U3078 Engine Mount Post - Rascal (pk 4)
U3079 Manifold - Rascal
U3080 Mounting Set; muffler - Rascal
U3081 Muffler - Rascal
U3082 Pinion Clutch Bell; 15T - Rascal
U3083 Pinion Service Kit - Rascal/Riot
U3084 Radio Switch & Wiring - Rascal
U3085 Thottle & Brake Link Set - Rascal
U3102 Fuel Tank - Rascal
U3104 Clutch Shoes & Spring - 18
U3108 Pinion Bell Service Kit; Needle Bearing

BATTERIES

G718 GP Alkaline AA Pencil; Card 4
G721 AA Pencil 2700NiMH - Card 4
G744 AAA 1000 NiMH - Card 4
G745 AAA Rx Battery NiMH 800 - 6.0v
G746 AAA Alkaline Battery - Card 4



NITRO MOTORS & PARTS

G69100 Schumacher R18 P/S Engine
G69101 Burn Room - Sch R18
G69102 Cylinder Head - Sch R18
G69103 Carb Main Body - Sch R18
G69104 Carb Complete - Sch R18
G69105 Cylinder Sleeve/Piston - Sch R18
G69106 Connecting Rod - Sch R18
G69107 Crankshaft - Sch R18
G69108 Head Shim Washer 1pcs - Sch R18
G69109 Wrist Pin - Sch R18
G69110 Cylinder Head Bolt 4pcs - Sch R18
G69111 Idle Adjust Screw - Sch R18
G69112 Carb Pinch Bolt - Sch R18
G69113 Circlips; Wrist Pin - Sch R18
G69114 Slide Assy; Carb - Sch R18
G69115 Needle Assy; Hi Speed - Sch R18
G69116 O Ring Set; Carb & Back Plate - Sch R18
G69117 Cone & Washer; Crankshaft - Sch R18
G69118 Plastic Parts; Pull Start - Sch R18
G69119 One Way Bearing Set - Sch R18
G69120 Back Plate - Sch R18
G69121 Starting Shaft - Sch R18
G69122 Rear Cover Bolts M2.6x6 - Sch R18
G69123 Pin & Spring; Pull Start - Sch R18
G69124 Glow Plug - Sch R18
G69125 Air Filter - Sch R18

SPEED SECRET - OPTION PARTS

NE412 Alloy Wheel Adaptors; 12mm - Rascal pk4
NE910 Chrome Moly Steel Roll Cage - Rascal
U1572 Titanium Turnbuckle; purple - 39mm (pr)
U1905 Titanium Turnbuckle; purple - 35mm (pr)
U2135 M4 Nyloc Wheel Nut - Purple Alloy (pk4)
U2165 Alloy Blocks & Flex Body Post - Vertical
U2810 M4 Nyloc Wheel Nut - Red Alloy (pk4)
U2811 M4 Nyloc Wheel Nut - Blue Alloy (pk4)
U2812 M4 Nyloc Wheel Nut - Black Alloy (pk4)
U2813 M4 Nyloc Wheel Nut - Gold Alloy (pk4)
U3090 Alloy Front Hub Carrier - Rascal
U3091 Alloy Front Yokes - Rascal
U3092 Alloy Rear Hub Carrier - Rascal
U3093 Alloy Wishbone; Fr or Rr - Rascal
U3094 2 Speed Gearbox - Rascal
U3096 Alloy Pivot Blocks - pk4
U3231 Alloy Front Axle - Rascal & Riot (pr)
U3232 Alloy Rear Axle - Rascal & Riot (pr)

ELECTRONICS

G829 Transmitter 27Mhz Wheel
G830 Transmitter 27Mhz 2 Stick
G831 Receiver 27Mhz
G833 Servo - 3.0 Kg Cm 0.19 sec/60deg
G837 Mini Temp Gun - 420F 230C
G851 Servo; Metal Gears - 9.0 Kg Cm 0.2 sec/60deg
H1033 Micro Failsafe; waterproof
H1042 Nicad Switch + Ext Charge Socket

TOOLS

H1016 Fuel Bottle - 250cc
H1017 Fuel Bottle - 500cc
H1018 5 Way Glow Plug Wrench
H1025 4 Way Glow Plug Wrench
H1030 Nitro Cleaner Aerosol 500ml
H1037 Pipercross Air Filter Oil - Aerosol
H1038 Pipercross Air Filter Cleaner - Aerosol
H1055 GT85 Lube & Clean Aerosol 400ml
U2789 Schumacher Hex Driver - 1.5mm
U2790 Schumacher Hex Driver - 2.0mm
U2791 Schumacher Hex Driver - 2.5mm
U2792 Schumacher Hex Driver - 3.0mm
U2794 Schumacher Driver - T10 TORX
U2795 Schumacher M3 Nut Driver
U2796 Schumacher M4 Nut Driver
U2818 Schumacher Body Reamer

Nitro Accessories



H1016 - 250cc Fuel Bottle
H1017 - 500cc Fuel Bottle
Both bottles feature a blue alloy pipe and include a stopper.



H1030 - Nitro Cleaner
Ideal for cars and engines.
Just Spray, and wipe off!



G837 - Mini Temp Gun
Ideal for measuring tyre, track and head temperature.



H1033 - Micro Waterproof Fallsafe



H1009 - Curved Scissors
Designed for cutting out polycarbonate bodies.



H1018 - 5 Way Glow Plug Spanner
Chrome Plated Plug Spanner 7mm, 8mm, 10mm, 12mm and 17mm across flats.



H1023 - "D" Cell Glow Starter
Easy to use. Requires a "D" cell battery.



U1552 - Silver Body Clips
H1010 - "Fluro" Yellow Body Clips
H1011 - "Fluro" Green Body Clips
H1012 - "Fluro" Red Body Clips
H1013 - "Metallic" Red Body Clips
H1014 - "Metallic" Blue Body Clips
H1015 - "Metallic" Purple Body Clips
All body clips come in packs of ten.



H1025 - 4 Way Glow Plug Spanner
Chrome Plated Plug Spanner 7mm, 8mm, 10mm, and 12mm across flats.



H1037 - Piper X Air Filter Oil
Add this to your air filter after cleaning. A must for dusty conditions.



H1038 - Piper X Air Filter Cleaner
Use this to clean your air filter, before adding air filter oil.



G200 - The Ultimate Lubel



Hex Driver - 1.5mm
U2789



Hex Driver - 2.0mm
U2790



Hex Driver - 2.5mm
U2791



Hex Driver - 3.0mm
U2792



Hex Driver - 0.050"
U2793



Torx Driver - T10
U2794



M3 Nut Driver
U2795



M4 Nut Driver
U2796



Body Reamer
U2818



U2851 - Purple Alloy Fuel Filter
Complete with Sintered Brass Filter.

G020 - 20 weight (thin)

G025 - 25 weight

G030 - 30 weight

G035 - 35 weight

G040 - 40 weight

G045 - 45 weight

G050 - 50 weight

G055 - 55 weight

G060 - 60 weight

G070 - 70 weight

G080 - 80 weight

G100 - 100 weight

G120 - 120 weight (thick)

The best silicone shock oil you can buy!



Distributed By:
SCHUMACHER RACING PRODUCTS Ltd.
73 Tenster Road - Moulton Park
Northampton - NN3 6AX - U.K.
Phone: 01604 730770 - Fax: 01604 750289
www.racing-cars.com