

Driver & Event	
Name	Michal Orlowski
Date	28/7/2018 Event Euros 2018
Weather	indoor
Result	Q8 and A3

Electrics & Chassis	
E.S.C LRP Flow-X	
Servo Sanwa ERG-BX	
Reciever	Sanwa RX-481
Lipo LRP LCG 3500	
Shorty LiPo	Front <input type="checkbox"/> Middle <input type="checkbox"/> Rear <input type="checkbox"/>
Centre Topdeck	Yes <input checked="" type="checkbox"/> No <input type="checkbox"/>
Front Topdeck Thickness	2.5mm <input checked="" type="checkbox"/> 3.0mm <input type="checkbox"/>
Rear Topdeck Thickness	2.5mm <input checked="" type="checkbox"/> 3.0mm <input type="checkbox"/>

Motor & Gearing	
Motor LRP X22 6.0T	
Rotor Diameter	12.3 mm
Timing	24.0 Deg
Spur	82
Pinion	20

Track Conditions	
Grip Level	High <input type="checkbox"/> Med <input type="checkbox"/> Low <input type="checkbox"/>
Type	Tight <input type="checkbox"/> Open <input type="checkbox"/> Mixed <input type="checkbox"/>
Surface	Clay <input type="checkbox"/> Astro <input type="checkbox"/> Grass <input type="checkbox"/>
	Mixed <input type="checkbox"/> Carpet <input type="checkbox"/>
Condition	Smooth <input checked="" type="checkbox"/> Bumpy <input type="checkbox"/>

Wheels & Tyres	
Rr Tyre	JC Dirt Webs Gold
Rr Wheel	Schumacher hex /U4366/
Rr Insert	JC Dirt Tech closed cell
Fr Tyre	JC Dirt Webs Gold
Fr Wheel	Schumacher hex /U4496/
Fr Insert	JC Dirt Tech closed cell

Other settings	
Car Weight	1720 g
Alloy Wing Mount	High <input type="checkbox"/> Low <input type="checkbox"/>
Rear Wing Gurney Height	low mm
Front Wing	Small <input type="checkbox"/> Big <input type="checkbox"/>
Front Wing Gurney Height	mm
Slipper	2Plate <input checked="" type="checkbox"/> 3Plate <input type="checkbox"/> 4Plate <input type="checkbox"/>
Rear Hex	0 <input type="checkbox"/> 0.75 <input type="checkbox"/> 1.5 <input type="checkbox"/>
Front Hex	0 <input type="checkbox"/> 0.75 <input type="checkbox"/> 1.5 <input type="checkbox"/>

Differential	
Diff Oil	F..15K.....cSt R..15K.....cSt
Diff Height F	High <input type="checkbox"/> Mid <input type="checkbox"/> Low <input type="checkbox"/>
Diff Height R	High <input checked="" type="checkbox"/> Mid <input type="checkbox"/> Low <input type="checkbox"/>

Front Shocks	
Oil..450.....cSt	Spring ..Green.3.4.....lb/in
Shock Cap	Sealed <input type="checkbox"/> Vented <input type="checkbox"/> Aeration <input checked="" type="checkbox"/>
Piston.blk.2.hole....	Drilled <input type="checkbox"/> Hole Size.1.6.....mm
Internal Limiters..0.5.....mm	Kashima Body No <input type="checkbox"/> Yes <input checked="" type="checkbox"/>



Rear Shocks	
Oil..400.....cSt	Spring Blue.2.4.....lb/in
Shock Cap	Sealed <input type="checkbox"/> Vented <input type="checkbox"/> Aeration <input checked="" type="checkbox"/>
Piston.red.2.hole....	Drilled <input checked="" type="checkbox"/> Hole Size.1.8.....mm
Internal Limiters..0.5.....mm	Kashima Body No <input type="checkbox"/> Yes <input checked="" type="checkbox"/>
Shock Stand Off Spacing..1.0.....mm	28.5.....mm

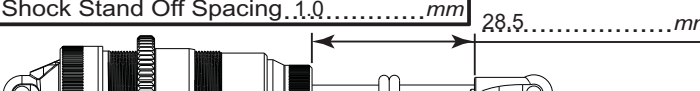

Front Suspension	
Toe	-.0.5.....Deg
Yoke	8° <input checked="" type="checkbox"/> 10° <input type="checkbox"/> 12° <input type="checkbox"/>
Anti Roll Bar	None <input type="checkbox"/> 1.2 <input type="checkbox"/> 1.4 <input type="checkbox"/> 1.6 <input type="checkbox"/> 1.8 <input type="checkbox"/> 2.0 <input type="checkbox"/>
Ride Height	.19.5.....mm
Camber at Ride Height	2.5.....Deg
Link Washers	.3.0.....mm
Wheelbase	Short <input type="checkbox"/> Long <input type="checkbox"/>
Shock Mount	C/F <input type="checkbox"/> S2 <input checked="" type="checkbox"/>
Bump Steer Washers	...0.0.....mm
Hub Spacer	High <input type="checkbox"/> Low <input type="checkbox"/>
Driveshaft	Kit <input type="checkbox"/> Roche <input type="checkbox"/>
Pin Angle	8° <input type="checkbox"/> 10° <input type="checkbox"/> 12° <input type="checkbox"/>
Pin Width	Narrow <input type="checkbox"/> Mid <input type="checkbox"/> Wide <input type="checkbox"/>

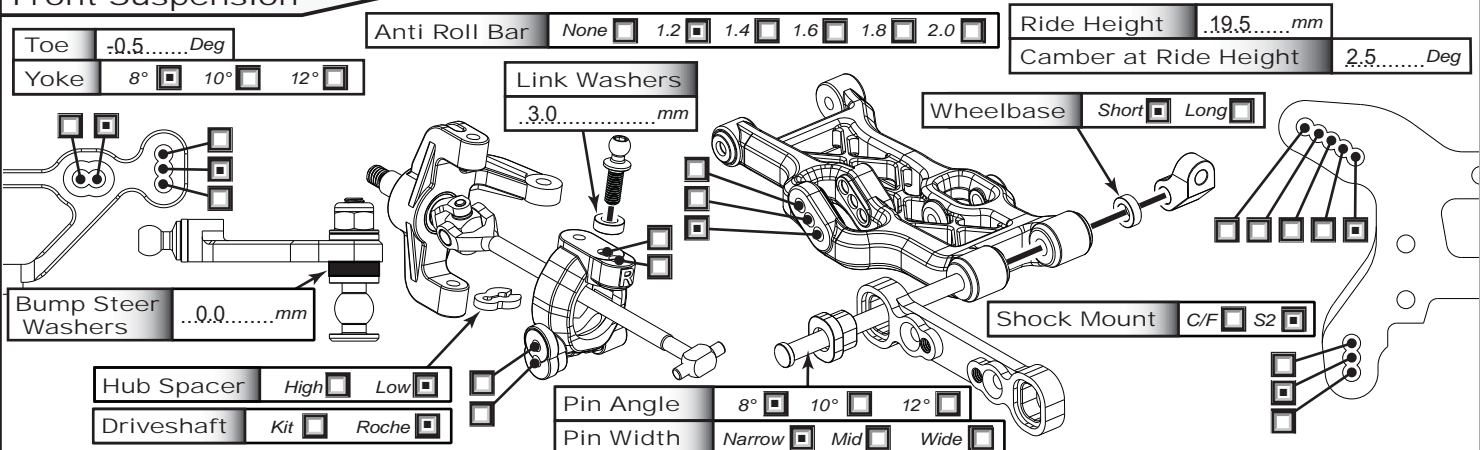

Rear Suspension	
Toe In (Kit Blocks)	3° <input type="checkbox"/> 2.5° <input type="checkbox"/>
Toe In (3.5°/2° Blocks)	3.5° <input type="checkbox"/> 2° <input type="checkbox"/>
Toe In (4°/1.5° Blocks)	4° <input type="checkbox"/> 1.5° <input type="checkbox"/>
Anti-squat	1° <input type="checkbox"/> 2° <input type="checkbox"/> 3° <input type="checkbox"/> 4° <input type="checkbox"/>
Anti Roll Bar	None <input type="checkbox"/> 1.2 <input type="checkbox"/> 1.4 <input type="checkbox"/> 1.6 <input type="checkbox"/> 1.8 <input type="checkbox"/> 2.0 <input type="checkbox"/>
Ride Height	.19.5.....mm
Camber at Ride Height	2.5.....Deg
Wheelbase	Short <input type="checkbox"/> Med <input type="checkbox"/> Long <input type="checkbox"/>
Shock Mount	C/F <input type="checkbox"/> S2 <input checked="" type="checkbox"/>
Wing Mount	Alloy <input type="checkbox"/> Kit <input type="checkbox"/>
Wing Washer	No <input type="checkbox"/> Yes <input type="checkbox"/>
Hub Washers	.....mm
Link Washers	.5.0.....mm
Rear Strap	High Pin (With front Riser) <input type="checkbox"/> Low Pin (Kit) <input type="checkbox"/>
Hub Carrier	Kit <input type="checkbox"/> Alloy <input type="checkbox"/>
Brass insert	Hi-Pin <input type="checkbox"/> Low-Pin <input type="checkbox"/>
Link Mount	Kit <input type="checkbox"/> Alloy <input type="checkbox"/>

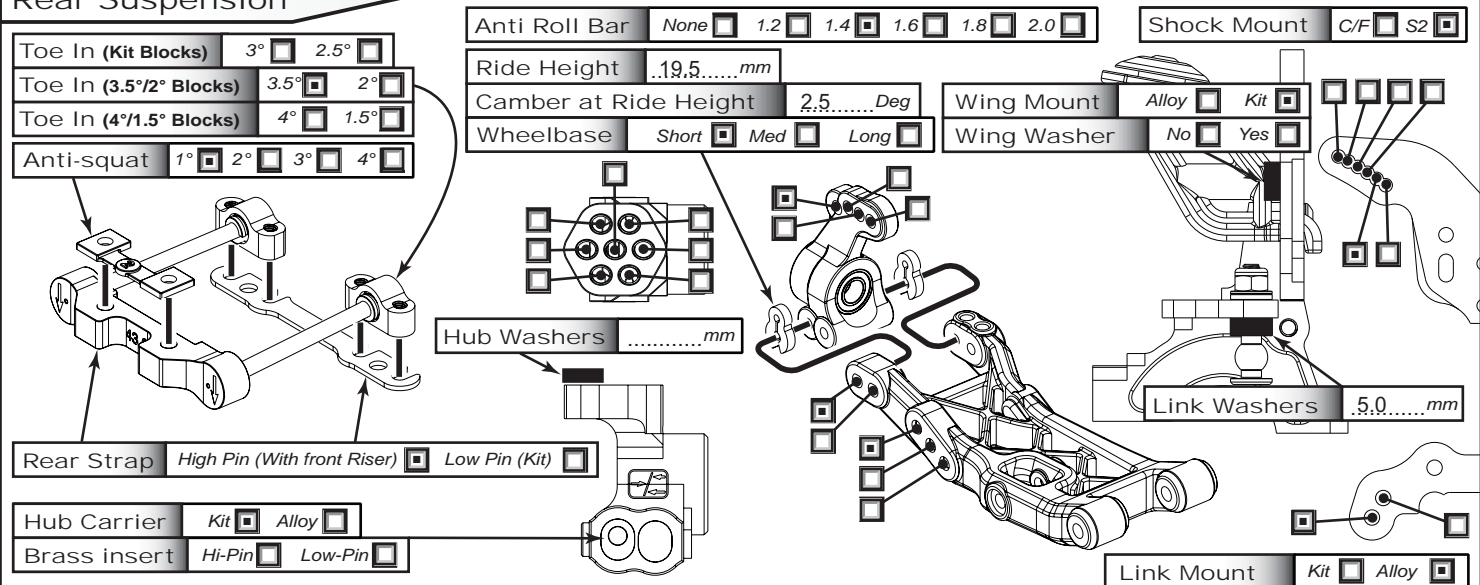

**Notes**

REMC indoor clay track. Reims, France.  
 ESC settings: 5-6-3-1-2-3-3-2-2  
 K2 AL front yoke 7.5 degree. Please ignore yoke information above  
 Front suspension setting: 8 degree rake, narrow track inserts, front wishbones shimmed 2.0mm backwards, no track washers.

