

# ICON<sup>2</sup>

Driver: \_\_\_\_\_ Track: \_\_\_\_\_ Event: \_\_\_\_\_  
 Date: \_\_\_\_\_ Qualifying: \_\_\_\_\_ Final: \_\_\_\_\_ Best Lap: \_\_\_\_\_

## TRACK TYPE

Grip Level High  Medium  Low   
 Type Tight  Open  Mixed   
 Condition Flat  Bumpy  Mixed   
 Surface Tarmac (Asphalt)  Carpet   
 Track Temp \_\_\_\_\_ °C  
 Weather \_\_\_\_\_

Notes:

## TYRES

Tyres \_\_\_\_\_  
 Cleaner \_\_\_\_\_  
 Additive \_\_\_\_\_  
 Additive Time Front: \_\_\_\_\_ mins Rear: \_\_\_\_\_ mins  
 Heating Time Front: \_\_\_\_\_ mins Rear: \_\_\_\_\_ mins  
 Heating Temp Front: \_\_\_\_\_ °C Rear: \_\_\_\_\_ °C

Notes:

## FRONT

KEY: CF = Carbon Fibre, AL = Aluminium, P = Plastic, F = Front, R = Rear  
 H = High, L = Low, Y = Yes, N = No, V = Vertical, H = Horizontal

Ride Height \_\_\_\_\_ mm  
 Droop \_\_\_\_\_ mm  
 Toe Out \_\_\_\_\_ deg St Links \_\_\_\_\_ mm  
 Servo Horn Height \_\_\_\_\_ mm Saver   
 Steering Travel \_\_\_\_\_ in \_\_\_\_\_ out  
 Castor \_\_\_\_\_ deg

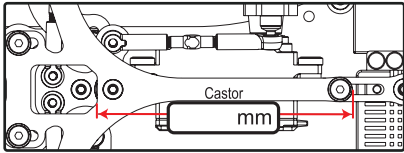

Notes:

Camber/Width Options

U8076 2° Wide  (kit)  
 U8123 2° -6mm   
 U8124 1.5° Wide   
 U8358 1.5° -6mm

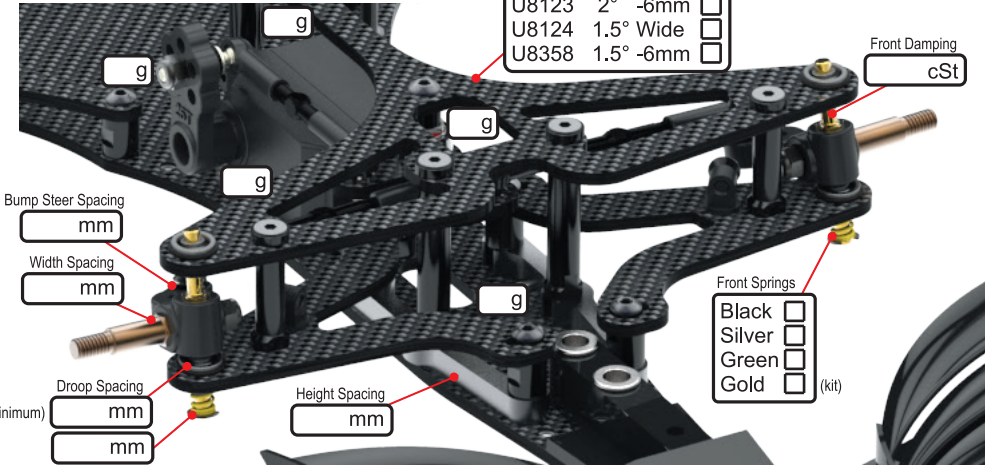

## REAR

KEY: CF = Carbon Fibre, AL = Aluminium, P = Plastic, F = Front, R = Rear  
 H = High, L = Low, Y = Yes, N = No, V = Vertical, H = Horizontal

Ride Height \_\_\_\_\_ mm  
 Droop \_\_\_\_\_ mm  
 Track width \_\_\_\_\_ mm  
 Diff Type Gear  Ball  Spool   
 Diff Oil (Gear Diffs) \_\_\_\_\_ cSt

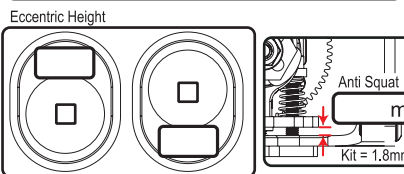

Notes:

Rear Spring

Black   
 Silver   
 Gold   
 Nickel   
 Red   
 Ultra  (kit)

Inner Width Spacing

\_\_\_\_\_ mm/side

Hex Width Spacing

\_\_\_\_\_ mm/side

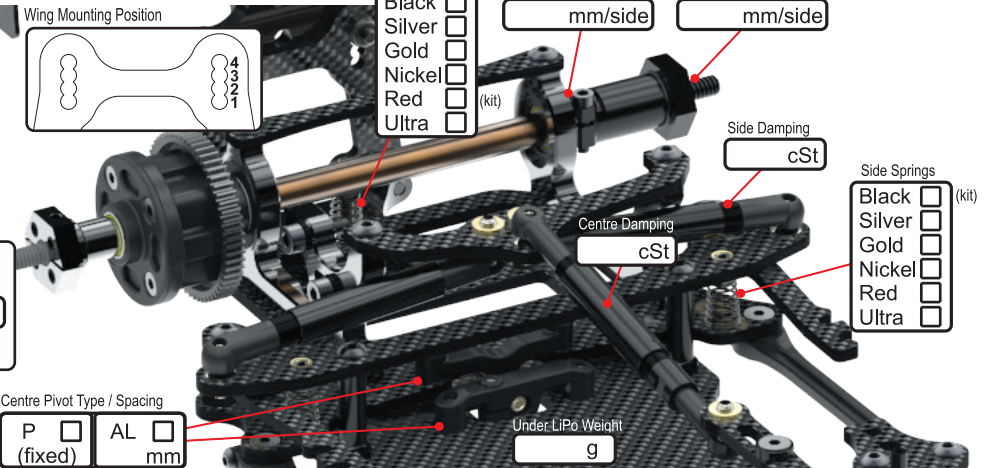

## BODYSHELL

Body \_\_\_\_\_  
 Rear Wing \_\_\_\_\_  
 Rear Wing Height \_\_\_\_\_ mm  
 Front Wing \_\_\_\_\_  
 Front Wing Flaps \_\_\_\_\_  
 Front Post Hole # \_\_\_\_\_  
 Front Post Hanger # \_\_\_\_\_  
 Rear Post Hole # \_\_\_\_\_  
 Rear Post Hanger # \_\_\_\_\_  
 Wing Offset Rwrld \_\_\_\_\_ mm  
 Body Weight \_\_\_\_\_ g

## CHASSIS

Chassis AL  CF   
 Wheelbase  
 Short  Long   
 Total Weight \_\_\_\_\_ g  
 Weight Distribution  
 F : R  
 Mass Dampers  
 F  \_\_\_\_\_ cSt  
 R  \_\_\_\_\_ cSt

Notes:

## ELECTRONICS

E.S.C. \_\_\_\_\_  
 Servo \_\_\_\_\_  
 RX \_\_\_\_\_  
 LiPo \_\_\_\_\_  
 Motor \_\_\_\_\_  
 Rotor Dia. \_\_\_\_\_ mm  
 Timing \_\_\_\_\_ deg  
 Gear Pitch 48  64   
 Pinion \_\_\_\_\_ t  
 Spur \_\_\_\_\_ t  
 Ratio \_\_\_\_\_

Notes: