

Driver and Event	
Name	TOM COCKERILL
Date	MAY 2013
Event	TEST
Weather	DRY - HOT
Result	NIA

Track Conditions	
Surface	CLAY - DIRT
Grip Level	MEDIUM - LOW
Track Condition	DUSTY

Additional Settings	
Car Weight	1760g
Washers between CTR and Bellcranks	0.0 mm
Chassis Alloy	<input checked="" type="checkbox"/>
Carbon	<input type="checkbox"/>

Electrics and Gearing	
E.S.C	NOSRAM COMET
Servo	ANDERSON
Receiver	KO
Batteries	NOSRAM 5700
Motor	NOSRAM 9.5
Spur	83T
Pinion	26T
Cell Position	FULLY BACK

Wheels and Tyres	
Rear Wheels	SCHUMACHER
Rear Tyre	PL HOLESHOT
Rear Insert	STD
Front Wheels	SCHUMACHER
Front Tyre	PROLINE RIB
Front Insert	STD

Diff Type	
Ball	<input type="checkbox"/>
Gear	<input checked="" type="checkbox"/>
Diff Oil	2000

NOTES

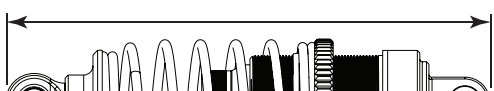
Front Shocks	
Oil CORE	Shock Cap Sealed <input checked="" type="checkbox"/>
Spring 450	Vented <input type="checkbox"/> Emulsion <input type="checkbox"/>
3.5lb/in	Piston 3 HOLE
Drilled <input type="checkbox"/>	Hole Size STD mm
	
Shock Length 85 mm	

Rear Shocks	
Oil CORE	Shock Cap Sealed <input checked="" type="checkbox"/>
Spring 350	Vented <input type="checkbox"/> Emulsion <input type="checkbox"/>
2.0lb/in	Piston 3 HOLE
Drilled <input type="checkbox"/>	Hole Size STD mm
	
Shock Length 97 mm	

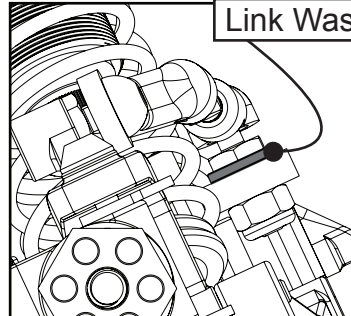
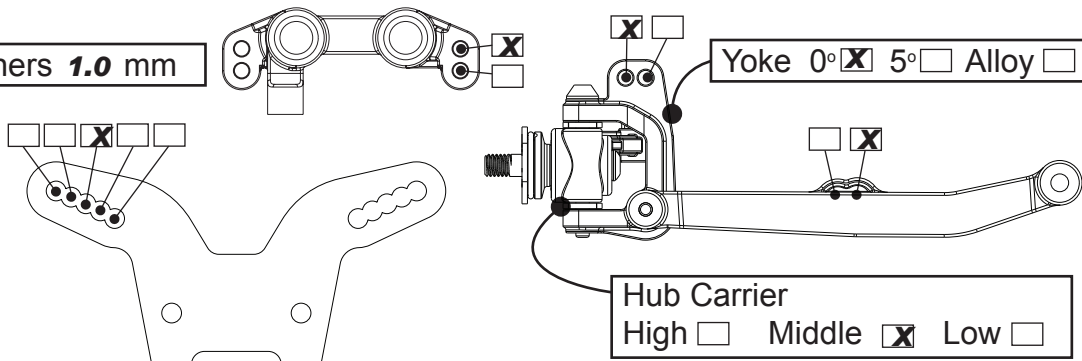
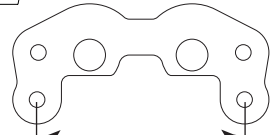
Front Suspension	
	Link Washers 1.0 mm
	
Yoke 0° <input checked="" type="checkbox"/> 5° <input type="checkbox"/> Alloy <input type="checkbox"/>	
Hub Carrier High <input type="checkbox"/> Middle <input checked="" type="checkbox"/> Low <input type="checkbox"/>	
Front Ride Height 24.0 mm	
Front Camber at Ride Height -1.0 Deg	
Front Toe In 0.0 Deg	
	
60.0 <input type="checkbox"/> 50.5 <input checked="" type="checkbox"/> 45.5 <input type="checkbox"/> 40.5 <input type="checkbox"/>	

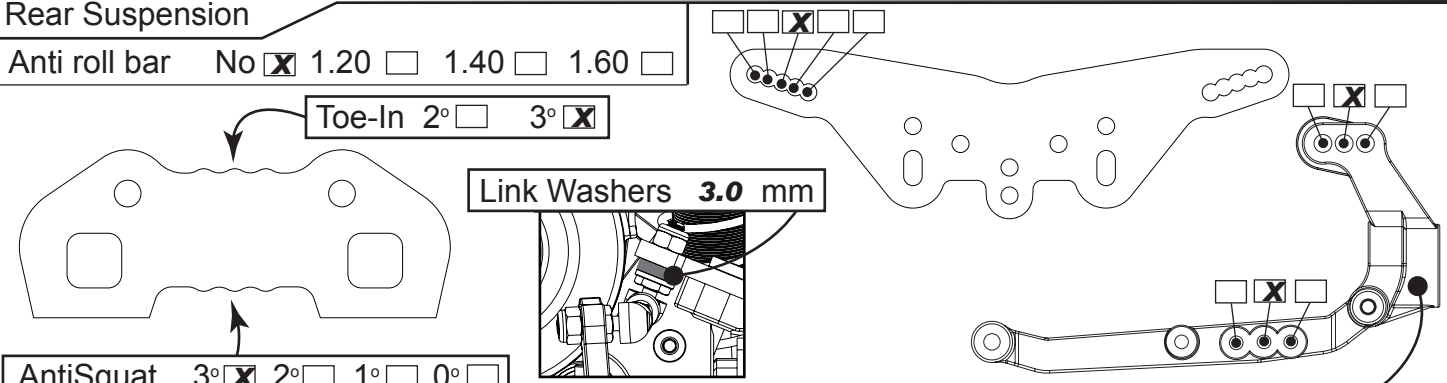
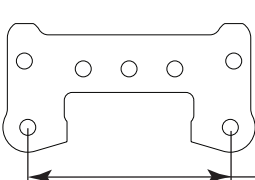
Rear Suspension	
Anti roll bar No <input checked="" type="checkbox"/> 1.20 <input type="checkbox"/> 1.40 <input type="checkbox"/> 1.60 <input type="checkbox"/>	
	
Toe-In 2° <input type="checkbox"/> 3° <input checked="" type="checkbox"/>	
Link Washers 3.0 mm	
AntiSquat 3° <input checked="" type="checkbox"/> 2° <input type="checkbox"/> 1° <input type="checkbox"/> 0° <input type="checkbox"/>	
Wheelbase Short <input type="checkbox"/> Med <input checked="" type="checkbox"/> Long <input type="checkbox"/>	
Rear Ride Height 24.0 mm	
Rear Camber at Ride Height -1.0 Deg	
	
Rear Hub Carrier Alloy <input type="checkbox"/> Std <input checked="" type="checkbox"/>	
Alloy Hub Carrier +1° <input type="checkbox"/> -1° <input type="checkbox"/>	
49 <input type="checkbox"/> 44 <input type="checkbox"/> 39 <input type="checkbox"/> 34 <input checked="" type="checkbox"/>	