

Setup Sheet

Driver Details

Name **Chris Ashton**

Date **Oct 2014**

Wheels and Tyres

Rear Foam **37**

Front Foam **47**

Rear Dia. **45.5 mm**

Front Dia. **44 mm**

Rear Additive **Full**

Front Additive **3/4**

Rear Glue Dots

Front Glue Dots

Notes

SXT Additive
30 minutes rear
20 minutes front

Surface

Track Type Smooth Bumpy Tight Open

Grip High Med Low

Chassis and Electrics

S1 Carbon

Bodyshell **GT Type A**

Wing **STD**

E.S.C **Hobbywing U3.1**

Servo **Core RC**

Receiver **KO**

Battery **TP 6800**

Motor and Gearing

Motor **TP 13.5**

Spur **68**

Pinion **32**

mm/rev **67**

Timing **37.50** Deg

1S Shorty

Front

Front Ride Height **3.5 mm**

Front Droop **2.0 mm**

Front Toe In **-1°**

Camber Plate 1° 1.5° 2°

Ackerman Washers **1.0 mm**

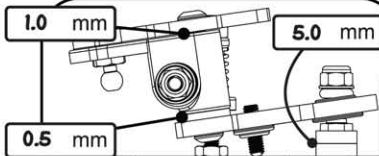

- 5lb/in White
- 7lb/in Yellow
- 10lb/in Blue
- 14lb/in Green
- 19lb/in Red
- 26lb/in Black

Centre

- None
- White
- Blue
- Red
- Black

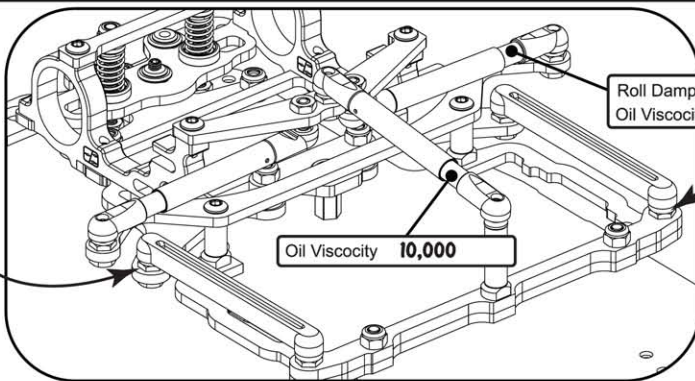

Roll Dampers Yes No
Oil Viscosity **10,000**

Oil Viscosity **10,000**

- None
- White
- Blue
- Red
- Black

Rear

Motor Spacer 0 1 2

Ride Height Adjuster



Rear Ride Height **3.5 mm**

- 5lb/in White
- 7lb/in Yellow
- 10lb/in Blue
- 14lb/in Green
- 19lb/in Red
- 26lb/in Black

Diff Yes No

30g Weight

Rear Droop **3.0 mm**

Rear Droop Screws 1 2

