

Driver and Event

Name	SIMON MOSS
Date	JULY 08
Event	EURO'S ITALY
Weather	FINE
Result	4TH

Track Conditions

Grip Level	MEDIUM
Surface	CRACKED CLAY
Track Condition	HARD CLAY SLIGHTLY BLUE GROOVES
Temperature	28°C

Electrics

E.S.C	SPEED PASSION GT		
Servo	SANWA ERG WRX		
Receiver	SANWA SPECT		
Type of Cells	SCH 4600 Ni-Mh		
Motor	SPEED PASSION 6.5		
Spur	83	Pinion	23
Internal Ratio	2.6		

Wheels - Tyres - Inserts

Front Wheels	SCH REVLITE
Front Inserts	STANDARD
Front Tyres	TAPER PINS (RED)
Rear Wheels	SCH REVLITE
Rear Inserts	PROLINE 2 STAGE
Rear Tyres	X 2000 (RED)

Transmission

Rear Diff Height	HIGH
Front Diff Height	LOW
Front Layshaft Pulley	FIXED
Front Drive	DIFF
Front Overdrive	NO

Notes

2 EXTRA FANS FOR TEMPERATURE CONTROL

Rear Suspension

Wheelbase	Short <input checked="" type="checkbox"/> Medium <input type="checkbox"/> Long <input type="checkbox"/>
-----------	---

Roll Bar	No <input checked="" type="checkbox"/> 1.2 <input type="checkbox"/> 1.4 <input type="checkbox"/> 1.6 <input type="checkbox"/>
----------	---

Equal Washers = 0° Toe-in
 0.50 Difference = 0.65° Toe-in
 1.00 Difference = 1.30° Toe-in
 1.50 Difference = 1.95° Toe-in
 2.00 Difference = 2.60° Toe-in
 2.50 Difference = 3.25° Toe-in
 3.00 Difference = 3.90° Toe-in

Toe-in / Rear Track Washers		
Rear 3.0 mm	Front 0.5 mm	Actual 3.25°

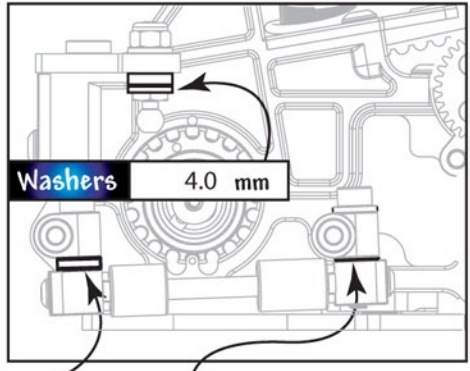
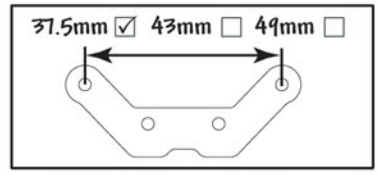
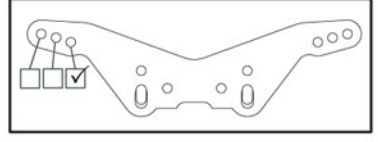
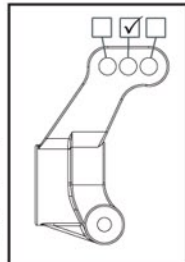
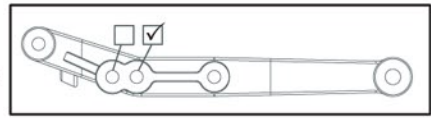
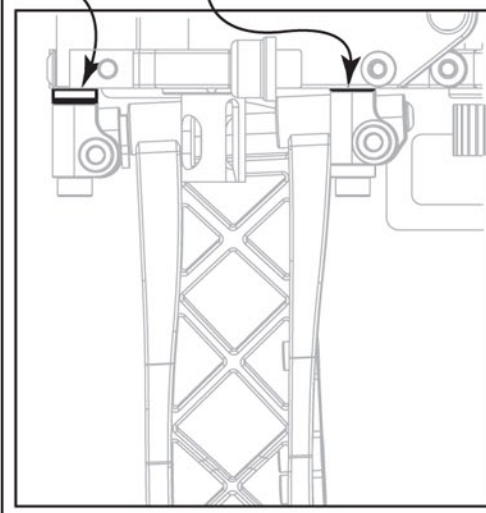

Washers 4.0 mm		
Rear 2.0 mm	Front 1.0 mm	Actual 1.30°
Anti-Squat Washers		

Note: The Anti-Squat Angle is worked out using the Toe-in Chart Above, as the washers produce the same angles.

Front Suspension

Front Track Washers	
Rear 1.0 mm	Front 1.0 mm

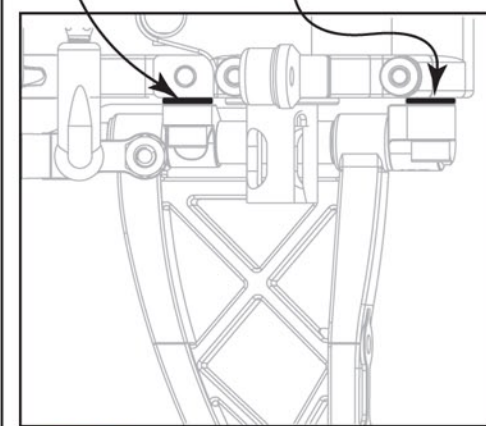

Roll Bar	No <input checked="" type="checkbox"/> 1.2 <input type="checkbox"/> 1.4 <input type="checkbox"/> 1.6 <input type="checkbox"/>
----------	---

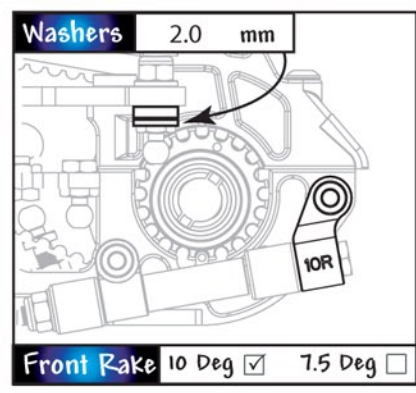
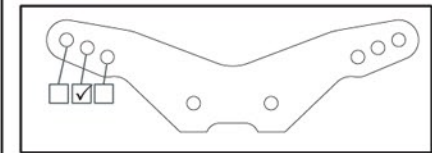

Washers 2.0 mm	
Front Rate	10 Deg <input checked="" type="checkbox"/> 7.5 Deg <input type="checkbox"/>

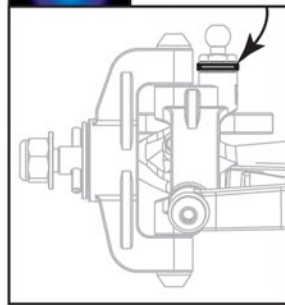

Washers 0 mm	
--------------	--

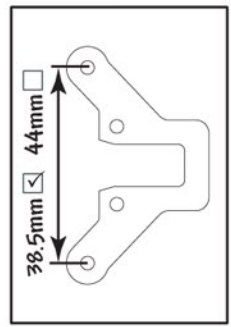
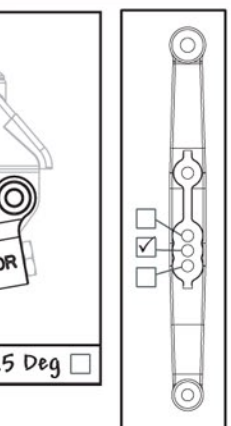

Rear Shocks

Oil	30WT	Piston	2 hole <input type="checkbox"/> 3 hole <input checked="" type="checkbox"/>
Springs	SCHUMACHER RED		
Diaphragm Spec	OPEN AIR/OIL		

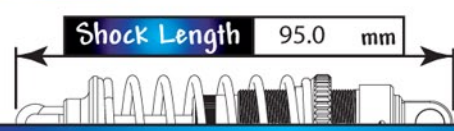

Front Shocks

Oil	25WT	Piston	2 hole <input type="checkbox"/> 3 hole <input checked="" type="checkbox"/>
Springs	SCHUMACHER YELLOW		
Diaphragm Spec	OPEN AIR/OIL		

