

Driver and Event

Name Tom Cockerill
 Date July '12
 Event Canadian Off Road Champs
 Weather Dry/Hot
 Result 6th

Track Conditions

Surface Clay
 Grip Level Medium
 Track Condition



Additional Settings

Car Weight
 Weights Added 40g Around Servo
 Weight Distribution
 Ride Height Front 23 mm
 Rear 23 mm
 Washers between CTR and Bellcranks 0 mm
 Chassis Alloy Carbon

Electrics and Gearing

E.S.C Speed Passion GT2.0 Pro
 Servo GM
 Receiver Sanwa
 Batteries Speed Power 5300
 Motor Speed Passion V3.0 7.5R
 Spur 80
 Pinion 25
 Cell Position
 10mm Foam Rear, Rest Front

Wheels and Tyres

Rear Wheels Schumacher FlexLite
 Rear Tyre AKA Vektor
 Rear Insert AKA Moulded
 Front Wheels Sch Medium FlexLite
 Front Tyre AKA Vektor
 Front Insert AKA Moulded
 Tyre Modifications

Diff Type

Ball Gear

NOTES

Rear Battery Posts Only

Rear Shocks

Oil 450 Spring 2.0
 Ball Short
 Socket Long
 Piston Holes 2 3 4 5 6
 Drilled Hole Size 1.3



Front Shocks

Oil 550 Spring 3.5
 Piston Holes 2 3 4 5 6
 Drilled Hole Size 1.4



Rear Suspension

Anti roll bar No 1.20 1.40 1.60

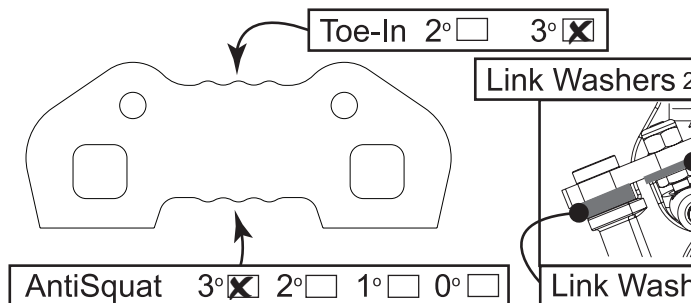

Wheelbase Short Med Long

Rear Camber at Ride Height -2.0

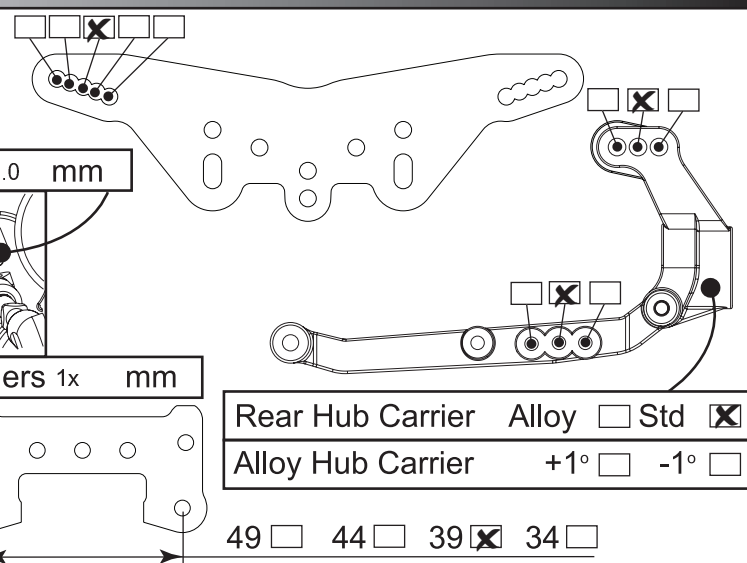

Front Suspension

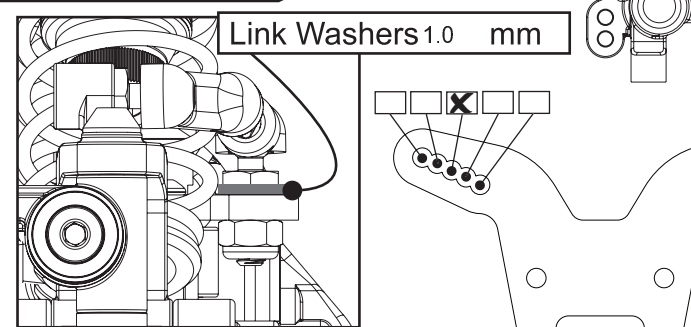

Front Camber at Ride Height -2.0

Front Toe In 0

