

DRIVER AND EVENT DETAILS

Name **Test Driver**
 Date _____
 Event **Basic Tarmac Setup**
 Weather **Dry**
 Result _____

CHASSIS AND ELECTRICS

Chassis **Euro 2008 5 cell (kit)**
 Top Deck **Euro 2008 (kit)**
 Bodyshell **East Coast Speed 6**
 Wing **Std**
 E.S.C **Speed Passion GT**
 Servo **KD**
 Receiver **KD**
 Number of Cells **4** **5** **6**
 Type of Cells **Ni-Mh**

TRACK CONDITIONS

Grip Level **High** **Medium** **Low**
 Track Type **Tight** **Open** **Both**
 Surface **Carpet** **Tarmac** **Wood**
 Venue **Indoor** **Outdoor**
 Track Condition **Smooth** **Bumpy**
 Track Temperature _____ °C _____ °F



DRIVER NOTES

0.5mm washer against front hex

MOTOR AND GEARING

Type **Brushed** **Brushless**
 Motor **Speed Passion**
 Brush _____
 Spring _____
 Timing **Std**
 Gear Pitch **48Dp** **64Dp**
 Spur Size **89**
 Pinion Size **23**

WHEELS, TYRES AND INSERTS

Wheels **XG-32CM**
 Tyres **Sorex (BRCA)**
 Inserts _____
 Tyre Additive **tweak**
 Additive Time **40 MIN (R) 40MIN (F)**
 Tyre Warmers **Yes** **No**

FRONT SETTINGS

Drive **Diff** **Spool** **One-Way** **Height** **High** **Low**

Servo Saver **Yes** **No**
 Toe In-Out **In-board** **Out-board** ° Toe-out _____
 Screw Block Spacers **Front 0.5 mm** **Rear 0.5 mm**
 Wishbone Quik-Klips **Front 1.0 mm** **Rear 3.0 mm**
 Link Washers (Horizontal) _____ **3.5 mm**
 Ride Height (Chassis to Floor) _____ **5.0 mm**
 Droop (Chassis to Floor) **25.4 (Axle Height) mm**
 Anti-roll Bar **Yes** **No** **1.20** **1.40** **1.60**
 Castor **0°** **2°** **4°** **6°**
 Camber **Positive** **Negative** **1.5 Deg**
 Link Washers (Vertical) _____ **1.0 mm**
 Inboard Pin **Kick-up** **Anti-dive** **Horizontal**
 Pivot Block Spacers **Front 1.0 mm** **Rear 1.0 mm**

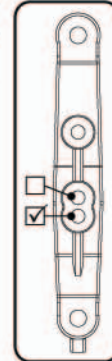
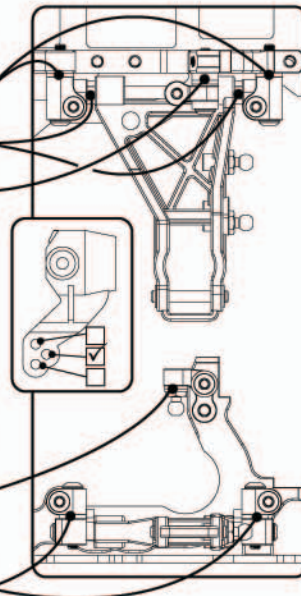

Front Shocks

Oil **30 WT**
 Springs **Blue**
 Piston Holes **2** **3**
 length **61.5**
 Rebound **75 %**

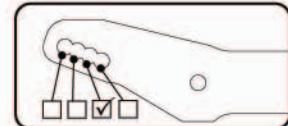

Centre Track Rod

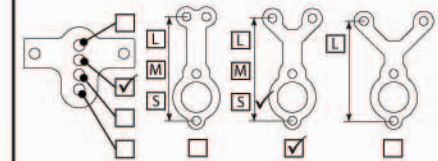

REAR SETTINGS

Drive Height **High** **Low**

Toe In **In-board** ° **Out-board** ° _____
 Screw Block Spacers **Front 2.0 mm** **Rear 1.0 mm**
 Wishbone Quik-Klips **Front 2.0 mm** **Rear 2.0 mm**
 Link Washers (Horizontal) _____ **3.0 mm**
 Ride Height (Chassis to Floor) _____ **5.5 mm**
 Droop (Chassis to Floor) **24.9 (axle height) mm**
 Anti-roll Bar **Yes** **No** **1.20** **1.40** **1.60**
 Camber **Positive** **Negative** **1.5 Deg**
 Link Washers (Vertical) _____ **2.5 mm**
 Inboard Pin **Pro-Squat** **Anti-Squat** **Horizontal**
 Pivot Block Spacers **Front 2.0 mm** **Rear 2.0 mm**

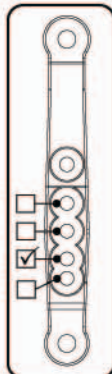
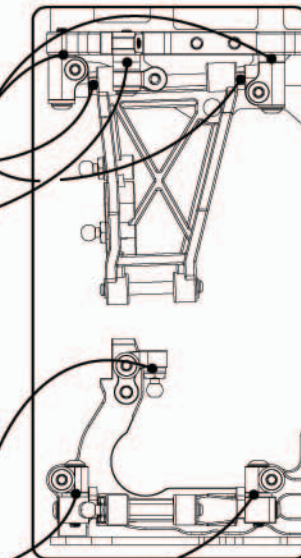

Rear Shocks

Oil **30 WT**
 Springs **White**
 Piston Holes **2** **3**
 length **62.5**
 Rebound **75 %**

Driver Notes

1mm washer against hex

