

STORMST2
PRO 1/10th 2WD Off-Road Stadium Truck

Driver: Tony Bishop Date: 24/6/24 Event/Track: Boughton Truck National
Qualify: 1st Final: 2nd Best Lap:

TRACK TYPE

Grip Level High Medium Low
 Type Tight Open Mixed
 Condition Flat Bumpy Mixed
 Surface Clay Long Astro Carpet
 Grass Short Astro Mixed
 Weather Sunny

TYRES

	FRONT	REAR
Tyres	Yellow Stagger	Yellow Vee 2
Wheels	U7999	U7999
Inserts	White Insert	White Insert

Notes:

Notes:

FRONT SUSPENSION

KEY: P = Plastic, A = Alloy, B = Brass, CF = Carbon Fibre, S2 = Schumacher Composite, M = Medium, S = Stiff, Sh = Short, H = High, L = Low, F = Front, R = Rear, Y = Yes, N = No

Ride Height 18 mm
 Wheelbase Sh L
 Toe 1 deg In Out
 Camber at Ride Height 1 deg
 Anti Roll Bar 1.2 1.3 1.4 1.5 1.6
 Bump Steer Washers 2 mm
 Pivot Block Height H M L

Notes:

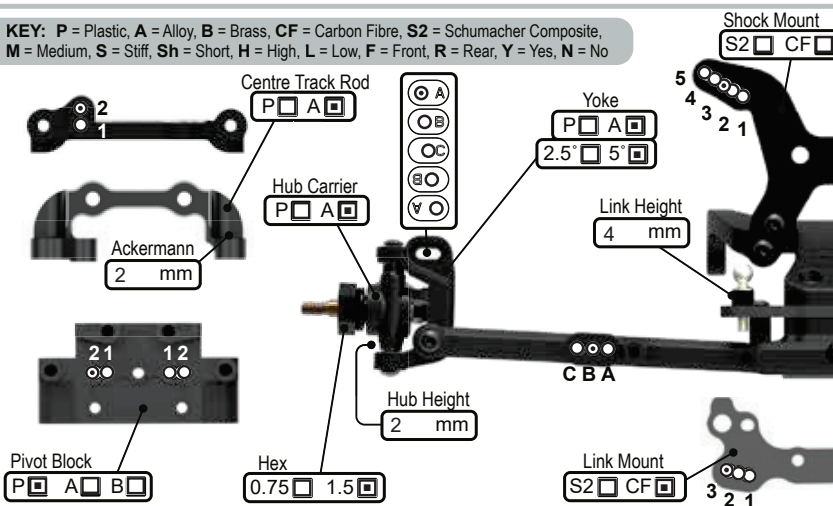

REAR SUSPENSION

KEY: P = Plastic, A = Alloy, B = Brass, CF = Carbon Fibre, S2 = Schumacher Composite, M = Medium, S = Stiff, Sh = Short, H = High, L = Low, F = Front, R = Rear, Y = Yes, N = No

Ride Height 18 mm
 Wheelbase Sh M L
 Anti-Squat 1 2 3 4
 Toe 4 3.5 3 2.5 2 1.5 1.0 0.5
 Camber at Ride Height 1.5 deg
 Anti Roll Bar 1.0 1.1 1.2 1.3 1.4
 Wing Gurney Height Kit mm
 Rearward Shock Position Only A B
 Driveshaft Type CVD U/J

Notes:

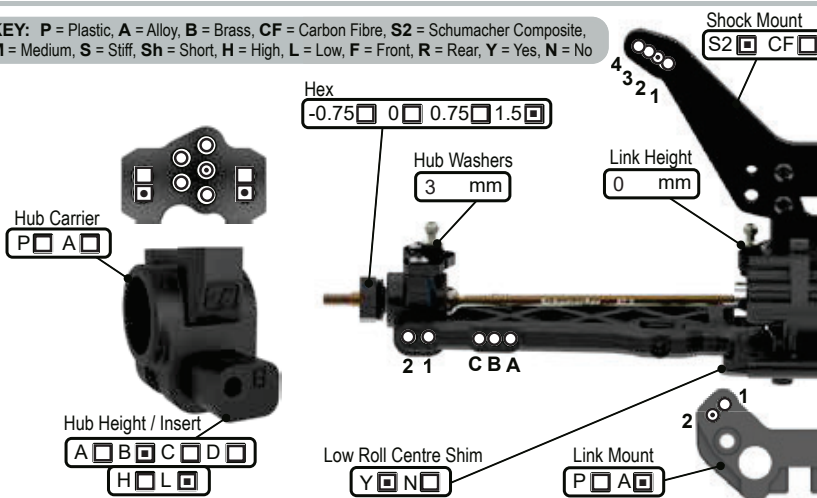

TRANSMISSION

Diff Height H M L
 Diff Oil cSt
 Diff Type B 2g 4g
 Motor 6T
 Rotor Dia. mm
 Timing 30 deg
 Pinion 19 t
 Spur 80 t
 Motor Plate A CF
 Lock Out Y N
 Slipper Plates 2 3

CHASSIS

Chassis A C/F
 Chassis Insert 0mm +5mm
 LiPo Position 1 2 3 4 5 6 7 8
 X Brace Y N
 Running Weight g
 Radio Tray 1 2 3

Notes:

EQUIPMENT

E.S.C. Hobby Wing
 Servo KO
 RX KO
 LiPo Interlet
 Bodyshell Kit

WEIGHTS

Chassis F R
 Rear Strap F R
 Radio Tray Y N
 Under LiPo Y N

SHOCKS

KEY: i = Internal, e = External, V = Vented, S = Sealed, A = Aeration

	FRONT	REAR
Cap	V <input type="checkbox"/> S <input type="checkbox"/> A <input type="checkbox"/>	V <input type="checkbox"/> S <input type="checkbox"/> A <input type="checkbox"/>
Body	Kit	Kit
Oil	500 cSt	400 cSt
Piston	3 x 1.5	2 x 2.1
Spring	Orange lb/in	Green lb/in
Limiters (i)	2 mm	0 mm
Stroke	27 mm	36 mm
Limiters (e)	mm	mm

Notes:

