



Driver: Tony Bishop Date: 20/8/23 Event/Track: Telford Truck National  
 Qualify: 1st Final: 1st Best Lap:

**TRACK TYPE**

Grip Level High  Medium  Low   
 Type Tight  Open  Mixed   
 Condition Flat  Bumpy  Mixed   
 Surface Clay  Long Astro  Carpet   
 Grass  Short Astro  Mixed   
 Weather Sunny

**TYRES**

	FRONT	REAR
Tyres	JC Concept Pink Swagger	Yellow MiniPin
Wheels	U7999	U7999
Inserts	JC Concept	Schumacher White

Notes:

**Notes:**

30g under lipo

**FRONT SUSPENSION**

KEY: P = Plastic, A = Alloy, B = Brass, CF = Carbon Fibre, S2 = Schumacher Composite, M = Medium, S = Stiff, Sh = Short, H = High, L = Low, F = Front, R = Rear, Y = Yes, N = No

Ride Height 18 mm  
 Wheelbase Sh  L   
 Toe 1 deg In  Out   
 Camber at Ride Height 1 deg  
 Anti Roll Bar 1.2  1.3  1.4  1.5  1.6   
 Bump Steer Washers 2 mm  
 Pivot Block Height H  M  L

Notes:

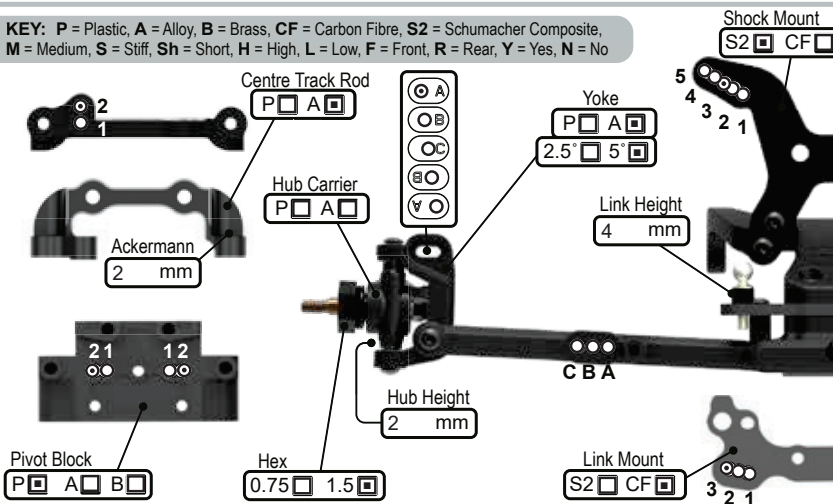

**REAR SUSPENSION**

KEY: P = Plastic, A = Alloy, B = Brass, CF = Carbon Fibre, S2 = Schumacher Composite, M = Medium, S = Stiff, Sh = Short, H = High, L = Low, F = Front, R = Rear, Y = Yes, N = No

Ride Height 18 mm  
 Wheelbase Sh  M  L   
 Anti-Squat 1°  2°  3°  4°   
 Toe 4°  3.5°  3°  2.5°  2°  1.5°  1.0°  0.5°   
 Camber at Ride Height 1 deg  
 Anti Roll Bar 1.0  1.1  1.2  1.3  1.4   
 Wing Gurney Height Kit mm  
 Rearward Shock Position Only A  B   
 Driveshaft Type CVD  U/J

Notes:

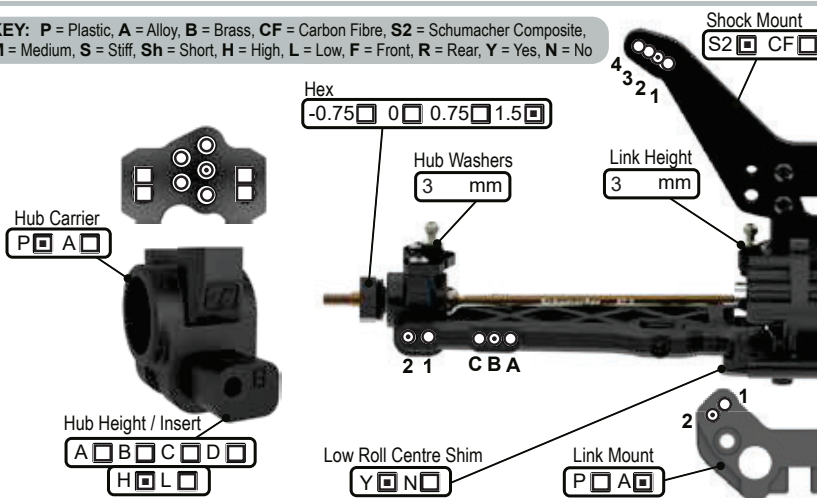

**TRANSMISSION**

Diff Height H  M  L   
 Diff Oil 7 cSt  
 Diff Type B  2g  4g   
 Motor 6T  
 Rotor Dia. mm  
 Timing 20 deg  
 Pinion 20 t  
 Spur 80 t  
 Motor Plate A  CF   
 Lock Out Y  N   
 Slipper Plates 2  3

**CHASSIS**

Chassis A  C/F   
 Chassis Insert 0mm  +5mm   
 LiPo Position 1  2  3  4  5  6  7  8   
 X Brace Y  N   
 Running Weight g  
 Radio Tray 1  2  3

Notes:

**EQUIPMENT**

E.S.C. Hobbywing  
 Servo KO  
 RX KO  
 LiPo Interlect  
 Bodyshell Aerox

**WEIGHTS**

Chassis F  R   
 Rear Strap F  R   
 Radio Tray Y  N   
 Under LiPo Y  N

**SHOCKS**

KEY: i = Internal, e = External, V = Vented, S = Sealed, A = Aeration

	FRONT	REAR
Cap	V <input type="checkbox"/> S <input type="checkbox"/> A <input type="checkbox"/>	V <input type="checkbox"/> S <input type="checkbox"/> A <input type="checkbox"/>
Body	Kit	Kit
Oil	550 cSt	450 cSt
Piston	3 x 1.5	2 x 2.1
Spring	Orange lb/in	Black lb/in
Limiters (i)	2 mm	0 mm
Stroke	27 mm	36 mm
Limiters (e)	mm	mm

Notes:

